

IEEE TUTORIAL ON THE PROTECTION OF SYNCHRONOUS GENERATORS

Second Edition, 2011

**Special Publication of the
IEEE Power System Relaying Committee**

2011 IEEE Tutorial on the Protection of Synchronous Generators, Second Edition, special publication of the IEEE Power System Relaying Committee (PSRC), © 2011 IEEE, based on IEEE Publication 95TP102, IEEE Tutorial on the Protection of Synchronous Generators by the Rotating Machinery Subcommittee of the IEEE, © 1995, by the Power System Relaying (PSR) Committee of the IEEE Power and Energy Society, and on IEEE Standard C37.102 IEEE Guide for AC Generator Protection, © 2006 IEEE.

Permission to reprint/republish this material for advertising or promotional purposes or for creating new collective works for resale or redistribution must be obtained from the IEEE by writing to pubs-permissions@ieee.org. By choosing to view this document, you agree to all provisions of the copyright laws protecting it.

Participants

The following is a list of the members of the working group for the revision of the IEEE Tutorial on the Protection of Synchronous Generators:

Michael Thompson, *Chair*

Christopher Ruckman, *Vice Chair*

Hasnain Ashrafi
Gabriel Benmouyal
Zeeky Bukhala
Stephen P. Conrad
Everett Fennell
Dale Finney
Dale Fredrickson
Jonathan D. Gardell
Juan Gers
Randy Hamilton

Wayne Hartmann
Gerald Johnson
Patrick M. Kerrigan
Sungsoo Kim
Prem Kumar
Hugo Monterrubio
Charles Mozina
Mukesh Nagpal
Brent Oxandale
Russell W. Patterson
Mike Reichard

Mohindar Sachdev
Kevin Stephan
Sudhir Thakur
Demetrios Tziouvaras
Joe Uchiyama
Quintin Verzosa, Jr.
Thomas Wiedman
Michael Wright
John Wang
Murty V. V. S. Yalla

Preface to the Second Edition

2011

The primary focus of power system relaying is to detect and isolate short circuits in the primary zones that make up the power system. Correctly designing and setting power system protection systems are complex skills to master. The systems need to meet dependability, security, sensitivity, selectivity, and speed requirements to detect and separate faulted zones from the power system. Many relay engineers focus their entire careers on short-circuit protection.

It is a small wonder that many engineers find themselves in unfamiliar territory when designing and setting relaying systems for synchronous generators—where short-circuit protection is only a small subset of the protective elements that are applied. Many of the electrical protective elements are there to detect abnormal operating conditions that, if not detected, could result in extensive mechanical and electrical damage to significant assets.

Unlike most other zones of the power system where faults can be cleared by opening all electrical sources to the faulted element, a synchronous generator is a system with mechanical (prime mover, inertia), dc electrical (field), and ac electrical (power system) sources of energy. An understanding of the interaction of these various energy sources is necessary to properly protect a synchronous generator.

In 1995, the Power System Relaying Committee published 95 TP 102 *Tutorial on the Protection of Synchronous Generators* to familiarize practicing relay engineers with the principles and practices for protecting synchronous generators. In 1995, I was a relative newcomer to relay engineering and found myself very uncomfortable when confronted with protection problems relating to large synchronous generators. The tutorial was an extremely helpful tool in learning and understanding the schemes. Here was a document that distilled the concepts to a manageable level with concise articles on each subject.

Fifteen years later, the state of the art (and science) has evolved a great deal. All of the IEEE guides relating to the subject have been extensively revised. New hazards have been identified, and new protection practices for mitigating those hazards have been brought into common usage. New technologies and algorithms to improve protection that were not previously available have been developed. Microprocessor technology (in its infancy in 1995) has nearly completely taken over the industry.

For these reasons, the Power System Relaying Committee of the IEEE Power and Energy Society formed a working group to update the *Tutorial on the Protection of Synchronous Generators*. We hope that the 2011 version of the tutorial lives up to the high bar set by the original. At this time, it would be appropriate to acknowledge the authors of the

original tutorial. Each of the authors of the new tutorial started from the excellent material provided by the original authors.

AUTHORS OF ORIGINAL TUTORIAL BY CHAPTER

Ch	Title	Authors
1	Fundamentals	C. J. Mozina
2	Generator Stator Phase Fault Protection	G. C. Parr
3	Field Ground Protection	A. C. Pierce
4	Stator Winding Ground Fault Protection	S. E. McPadden and T. S. Sidhu
5	Abnormal Frequency Protection	E. C. Fennell and M. Bajpai
6	Overexcitation and Overvoltage Protection	K. C. Kozminski, W. G. Hartmann, and S. E. McPadden
7	Voltage Transformer Signal Loss	J. D. Gardell
8	Loss of Field Protection	M. V. V. S. Yalla
9	Out-Of-Step Relay Protection of Generators	D. W. Smaha
10	Current Unbalance (Negative-Sequence) Protection	P. W. Powell
11	System Backup Protection	P. W. Powell
12	Inadvertent Generator Energizing	C. J. Mozina and G. C. Parr
13	Generator Breaker Failure	S. C. Patel, H. J. King, and M. V. V. S. Yalla
14	Generator Tripping	E. C. Fennell and K. C. Kozminski

The new tutorial has been reorganized from the original, and chapters have been added. The content of the tutorial is divided into the following sections:

1. Fundamentals
2. Fault Protection
3. Abnormal Operating Condition Protection
4. Offline and Special Operating Mode Protection
5. System Design

In addition to the authors who are credited to each chapter, it is important to also acknowledge the working group members who provided technical review of each of the chapters. Their efforts helped to ensure technical accuracy and clarity of the information presented.

The working group would like to acknowledge the professional editorial review and formatting services provided by the Marketing Communications Department at Schweitzer Engineering Laboratories, Inc. Their contributions have ensured the professional appearance of the document.

Sincerely,
 Michael Thompson
 Chair, IEEE, PES, PSRC Working Group J8

Preface to the First Edition

1995

In the early 1990s, the Power System Relaying Committee conducted a survey to determine how major synchronous generators in North America were protected from short circuits and other abnormal electrical conditions. The result surprised those who conducted the survey. The major results of the survey indicated clearly that the responding protection engineering population, with a few notable exceptions, appeared to have little knowledge about the electrical protection of synchronous generators. In retrospect, this response was probably not altogether unexpected. In the past ten years, utilities have built few new generating plants. During this same period, many companies have downsized. These two factors have resulted in the loss of engineering expertise in the area of generator protection.

Survey findings also indicated that despite the clear need to upgrade older generator protection schemes to meet current IEEE/ANSI C37 guide recommendations, utilities seemed reluctant to go into existing power plants to make needed modifications. This may be due to several factors: a lack of expertise, a misguided belief that generators do not fail often enough to warrant proper protection, a belief that operating procedures will cover protection design deficiencies. Also, there was little understanding of new concepts and protection schemes such as inadvertent energizing, 100 percent stator ground protection, and sequential tripping.

The response of the Power System Relaying Committee to the survey results has been twofold:

1. We are strengthening our C37 guides, which relate to generator protection, to more clearly indicate the need for the described protection and the risks of not providing it.
2. We have prepared this tutorial that we hope will provide the background necessary to better understand our C37 guides that relate to this subject and to publicize that these guides exist.

Contrary to the belief of some, generators do fail due to short circuits or abnormal electrical conditions. In many cases, these failures can be prevented by proper generator protection. Generators, unlike some other power system components, need to be protected not only from short circuits but also from abnormal operating conditions such as overexcitation, overvoltage, loss of field, unbalance currents, and abnormal frequency conditions. When subjected to these abnormal conditions, damage or complete failure can occur within seconds thus requiring automatic detection and isolation.

In preparing the tutorial, we have drawn on the considerable expertise that resides in the Power System Relaying Committee. We used a Task Force approach to write the document. The Task Force tried to focus on the needs of utility and consulting engineers who are involved in generator protection. We concentrated on those areas of generator protection our survey indicated were the most misunderstood. In many cases, we explained our C37 guides, which relate to specific protection areas. There are fourteen (14) sections of the tutorial. References, included in each section, provide even more detail.

The individuals participating in this tutorial effort have generously donated their time and effort to produce what I believe is a very valuable document. I would like to express my appreciation to all the members of the Tutorial Task Force who worked so hard to produce and edit this document in record time. I'd like to specifically thank the individual section authors. Without their efforts, this document would not have been completed. It is our hope that this effort will contribute to the better understanding of this important subject.

C. J. Mozina
Editor
Tutorial Coordinator

Contents

Chapter 1 Fundamentals

Chapter 2 Fault Protection

- Section 2.1 Stator Phase Fault Protection
- Section 2.2 Stator Ground Fault Protection
- Section 2.3 Field Fault Protection
- Section 2.4 System Backup Protection
- Section 2.5 Generator Breaker Failure

Chapter 3 Abnormal Operating Condition Protection

- Section 3.1 Abnormal Frequency Protection
- Section 3.2 Overexcitation and Overvoltage Protection
- Section 3.3 Underexcitation/Loss-of-Excitation Protection
- Section 3.4 Current Unbalance (Negative-Sequence) Protection
- Section 3.5 Loss of Prime Mover (Antimotoring) Protection
- Section 3.6 Out-of-Step Protection
- Section 3.7 Voltage Transformer Signal Loss

Chapter 4 Offline and Special Operating Mode Protection

- Section 4.1 Inadvertent Energization Protection
- Section 4.2 Other Protective Considerations

Chapter 5 System Design

- Section 5.1 Tripping Modes
- Section 5.2 Multifunction Generator Protection Systems

Fundamentals

Charles J. Mozina and Jonathan D. Gardell

Abstract—This introductory chapter of the tutorial provides basic background information to better understand the chapters that follow. It is intended to provide information for the less experienced engineer. This chapter describes the electrical workings and dynamics of synchronous generators and their connections to the power system. Generator performance under short-circuit conditions is also described, along with generator grounding practices. In addition, some of the most misunderstood aspects of generator protection are also addressed. Finally, the IEEE C37 guides that relate to generator protection are enumerated along with the definitions of relay device numbers.

I. INTRODUCTION

The protection of synchronous generators involves the considerations of more harmful abnormal operating conditions than the protection of any other power system element. In a properly protected generator, automatic protection against harmful abnormal conditions is required. The bulk of this tutorial deals with the need to provide such protection. The objections of some to the addition of such protection is not so much that it will fail to operate when it should, but that it might operate improperly to remove a generator from service unnecessarily. This fear of applying proper protection can be greatly reduced by understanding the need for such protection and how to apply it to a given generator so it does not misoperate. Unnecessary generator tripping is undesirable, but the consequences of not tripping and damaging the machine are far worse. The cost to the utility for such an occurrence is not only the cost of repair or replacement of the damaged machine, but also the substantial cost of purchasing replacement power while the unit is out of service. At manned locations, an alert and skillful operator can sometimes avoid removing a generator from service by correcting the abnormal condition. In the vast majority of cases, however, the event will occur too rapidly for the operator to react; thus, automatic detection and isolation are required. Operators have also mistakenly created abnormal conditions where tripping to

avoid damage is required. Inadvertent energizing and overexcitation are examples of such events. Operating procedures are not a substitute for proper automatic protection and cannot be relied on to successfully protect the generator.

II. BASIC SYNCHRONOUS GENERATORS

A synchronous generator converts mechanical/thermal energy into electrical energy. The mechanical power of the prime mover rotates the shaft of the generator on which the dc field is installed. Fig.1 illustrates a simple generating machine.

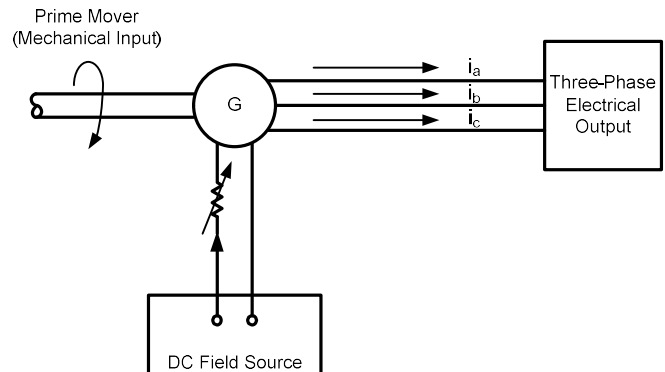

Fig. 1. Basic Synchronous Generator

Prime mover energy can be obtained from burning fossil fuels such as coal, oil, or natural gas. The energy that is produced turns the generator shaft (rotor) at typical speeds of 1,800 or 3,600 rpm on a 60 Hz system. Energy is converted to mechanical rotation in a turbine. At nuclear plants, uranium fuel is converted to heat through the fission process that produces steam. Steam is forced through a steam turbine to rotate the generator shaft. Prime mover energy can also be obtained from falling or moving water. Hydroelectric generators rotate much slower (around 100 to 300 rpm) than steam turbines.

Synchronous machines are classified into two principal designs: round rotor and salient pole. Fig. 2 provides a cross-sectional view of both construction types. Generators driven by fossil fuel turbines have cylindrical (round) rotors with slots into which distributed field windings are placed. Most cylindrical rotors are made of solid steel forgings. The number of poles is typically two or four. Generators driven by water wheels (hydraulic turbines) have laminated salient-pole rotors with concentrated field windings and a large number of poles. Whatever type of prime mover or machine design, the energy source used to turn the shaft is maintained at a constant level through a speed regulator known as a governor. The dc flux rotation in the generator field reacts with the stator windings, and because of the induction principle, a three-phase voltage is generated.

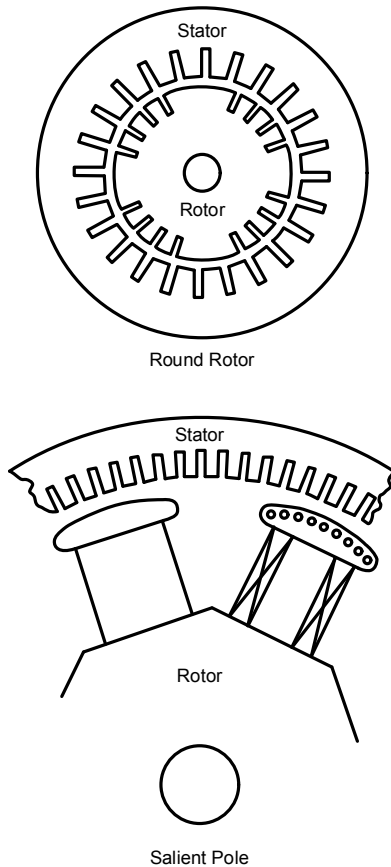

Fig. 2. Synchronous Generator Types

III. CONNECTION OF GENERATORS TO THE POWER SYSTEM

Two basic methods are used within the industry to connect generators to the power system: direct and unit connections.

A. Direct Connection

Fig. 3a shows the one-line diagram for a direct connection of a generator to the power system. The generator is connected to its load bus without going through a voltage transformation and supplies power directly to the load. This type of connection is an earlier method used when generators were small in size. It is still used today to connect smaller machines, especially in industrial cogeneration, to facility distribution systems.

B. Unit Connection

Fig. 3b shows the one-line diagram for a unit connection of a generator to the power system through a dedicated step-up transformer. Auxiliary generator load is supplied from a step-down transformer connected to the generator terminals. Most large generators are connected to the power system in this manner using a wye-delta, step-up main transformer connection. By connecting the generator to a delta system, ground fault current can be dramatically reduced using high-impedance grounding. Basic grounding practices are addressed later in this tutorial chapter and again in more detail in Chapter 2.2.

a) Direct Connected

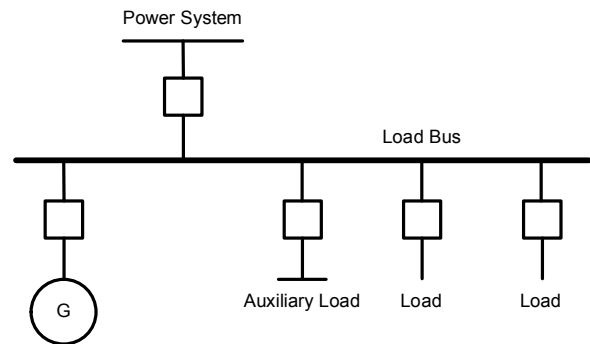

b) Unit Connected

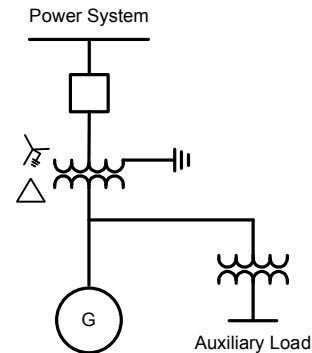

Fig. 3. Generator Connections

IV. SYNCHRONOUS GENERATOR SHORT-CIRCUIT BEHAVIOR

The equivalent electrical circuit of a synchronous generator is an internal voltage in series with impedance. For fault current calculation, the resistance component of the generator impedance is small compared to the reactance and is usually neglected. Fig. 4 shows the symmetrical component representation of a generator. Symmetrical component analysis is an important mathematical tool to calculate generator currents and voltages under unbalanced conditions. References [1] and [2] provide good basic information on this subject.

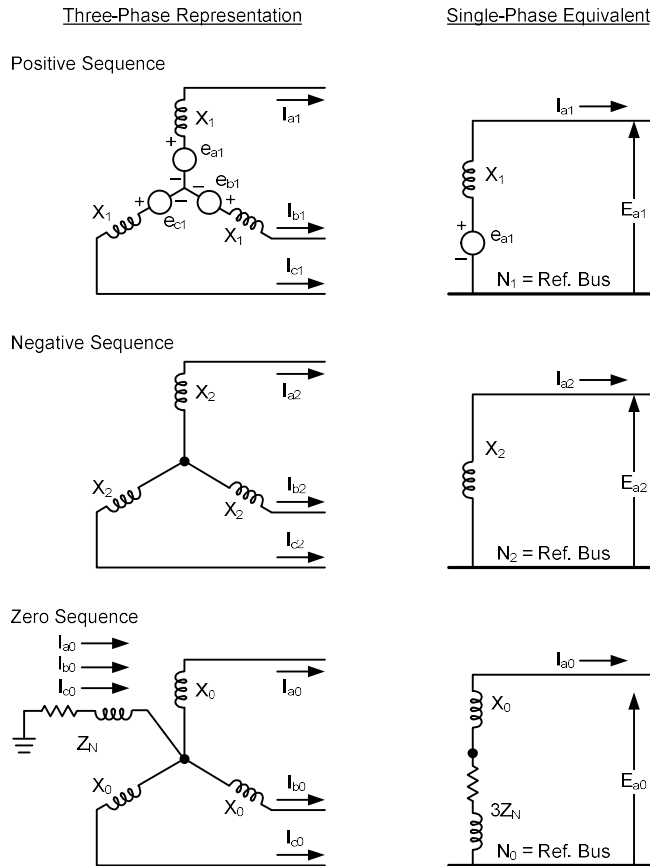

Fig. 4. Symmetrical Component Representation

A. Positive Sequence (X_1)

Three different positive-sequence reactance values are used. In the positive-sequence equivalent circuit, X_d'' indicates the subtransient reactance, X_d' the transient reactance, and X_d the direct-axis generator reactance. All of these direct-axis values are necessary for calculating the short-circuit current value at different times after the short circuit

occurs. They are provided by the generator manufacturer as part of the generator test sheet data. Since the subtransient reactance value gives the highest initial current value, it is generally used in system short-circuit calculations for relay applications. The transient reactance value is used for stability consideration.

Calculations of short-circuit performance and fault currents are a function of the generator (stator and field) characteristics, time, and load conditions immediately before the fault. The excitation system performance and characteristics dictate the ability of the generator to provide fault current during this condition. The excitation system will also attempt to keep voltage as high as possible by field-forcing, causing higher terminal voltages. The generator is generally operating in a saturated condition. To calculate fault current, saturated reactance is used with the generator initially operating at no load and at rated voltage. During normal generator operation at near-rated voltage, the reactance values during a fault are ideally somewhere between the saturated and unsaturated values. Exact values depend on the specific pre-fault conditions and saturation level. Thus, it is suggested that saturated values be used to calculate fault current [3]. Other pre-fault operating conditions may be reasons to adjust these suggested values for a specific case. Saturated reactance values are lower and therefore provide a more conservative, higher calculated fault current.

B. Negative Sequence (X_2)

The flow of negative-sequence current is of opposite phase rotation through the machine and appears as a double-frequency (120 Hz in a 60 Hz system) current in the rotor. The average of the direct-axis subtransient reactance under and between the poles gives a good approximation of negative-sequence reactance. In a salient-pole machine, negative sequence is the average of the subtransient direct-axis and quadrature-axis reactances ($X_2 = (X_d'' + X_q'')/2$), but in a round-rotor machine, X_2 equals X_d'' .

C. Zero Sequence (X_0)

The zero-sequence reactance is less than the positive- and negative-sequence values. Because of the high available ground fault current for a solidly grounded machine, impedance (reactance or resistance) is almost always inserted in the neutral grounding path, except on very small generators where the cost of providing such grounding in relationship to the machine cost is significant. In addition, generators are only mechanically designed for a bolted, three-phase terminal fault. A solidly grounded generator line-to-ground fault current level can exceed this value because of the very low zero-sequence reactance.

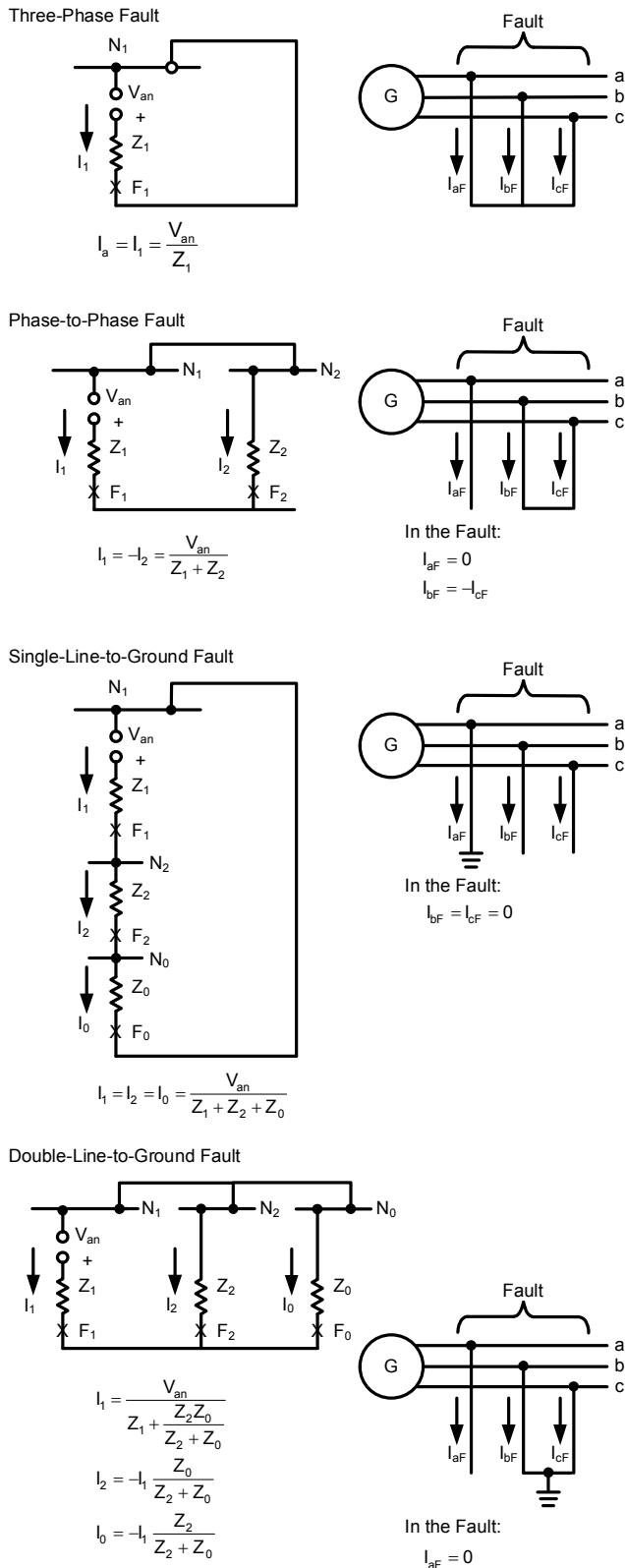

Fig. 5. Fault Sequence Network Connections

As previously stated, the stator winding resistance is generally small enough to be neglected in calculating short circuits. This resistance is important, however, in determining the dc time constants of an asymmetrical short-circuit current. To calculate faults or unbalanced abnormal generator conditions, the positive-, negative-, and zero-sequence networks are interconnected. References [1] and [2] provide more information on this subject. For common fault conditions, these impedances are connected as shown in Fig. 5.

D. Generator Fault Current Decay

Because the generator positive sequence is characterized by three reactances with increasing values over time, its fault current decays with time.

Fig. 6 illustrates a single-phase symmetrical trace of a three-phase, short-circuit waveform (dc component absent), such as might be obtained with oscillographs. The waveform shown in Fig. 6 can be divided into three periods, or time regions, as follows:

- Subtransient Period. This period lasts for a few cycles during which the current magnitude is determined by the generator subtransient reactance (X_d'') and decay time by time constant T_d'' .
- Transient Period. This period covers a relatively longer time during which the current magnitude is determined by the generator transient reactance (X_d') and decay time by time constant T_d' .
- Steady-State Period. This period is the longest time frame of generator fault current whose magnitude is determined by the generator direct-axis reactance (X_d).

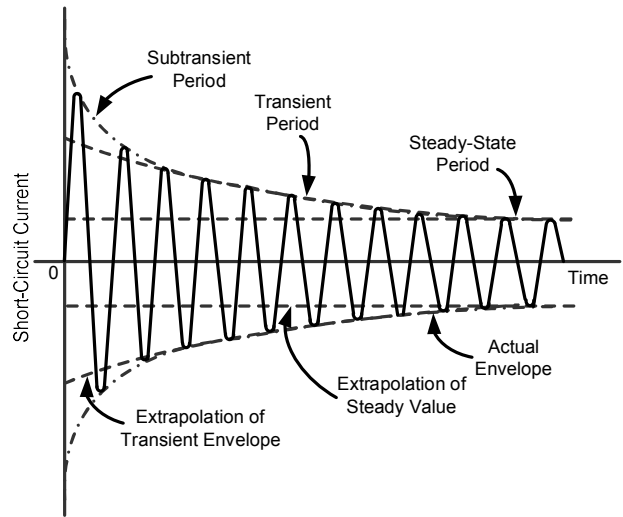

Fig. 6. Symmetrical Trace of a Generator Short-Circuit Current

When dc offsets are considered, generator currents for a three-phase fault resemble those shown in Fig. 7.

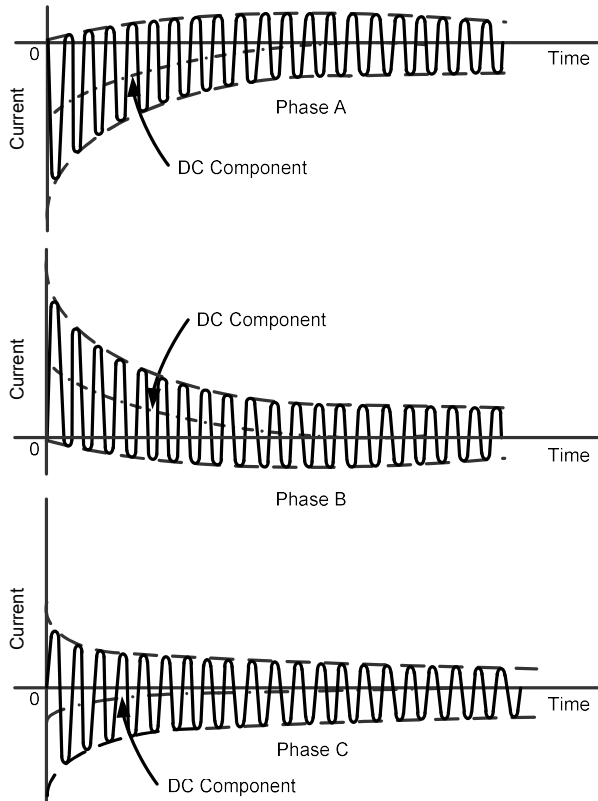

Fig. 7. Generator Short-Circuit Currents for a Three-Phase Fault With DC Offset

A generator fault detected by protective relays is separated from the power system by tripping the generator breaker, field breaker, and prime mover.

The system contribution to the fault will immediately be removed when the generator breaker trips, as illustrated in Fig. 8. However, the generator current will continue to flow after tripping. The generator short-circuit current cannot be “turned off” instantaneously because of the stored energy in the rotating machine. Fault current will continue to flow for several seconds after the generator has been tripped, making generator faults extremely damaging. Generator terminal leads are usually isolated through bus construction to minimize multiphase terminal faults (isolated phase bus). To substantially reduce ground fault currents, the generator is also grounded by increasing the zero-sequence impedance through inserting neutral-ground impedance.

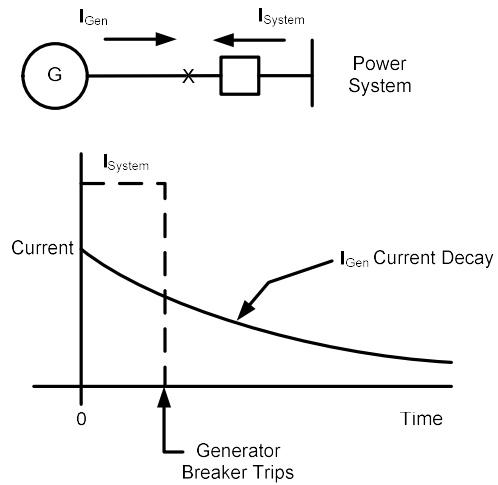

Fig. 8. Generator Terminal Fault Current

V. GENERATOR GROUNDING PRACTICES

High- and low-impedance grounding represent the two major methods used within the industry to ground generator stator windings. Recently, hybrid grounding has become popular in industrial generators to reduce stator ground fault damage.

A. Low-Impedance Grounding (LRG)

Fig. 9a illustrates a generator grounded through a resistor or reactor. The grounding resistor or reactor is selected to limit the generator ground fault contribution to current between 200 amperes to 150 percent of generator-rated current. LRG is generally used when multiple generating units operate on a common bus or directly connect to load buses without a voltage transformation providing the ground source for the system.

B. High-Impedance Grounding (HRG)

Fig. 9b illustrates a generator grounded using a distribution transformer with a secondary resistor. This grounding method allows the ground fault current to be reduced to low levels, typically 5 to 25 amperes. It is used on unit-connected generators.

C. Hybrid Grounding

Fig. 9c illustrates a hybrid-grounded generator. Combining HRG and LRG, this grounding method is used primarily at industrial facilities to reduce damage during stator ground faults [4]. The generator normally operates with both ground sources in parallel. When a generator ground fault is sensed, the high-speed switch in series with the LRG is tripped during generator shutdown to reduce damaging ground fault current during generator “coast down.”

a) Low-Impedance Grounding

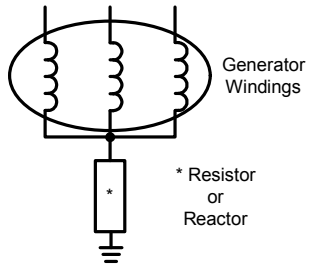

b) High-Impedance Grounding

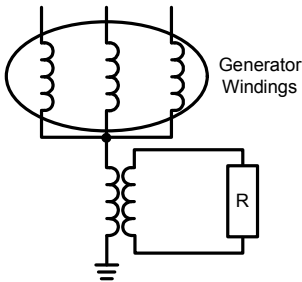

c) Hybrid Grounding

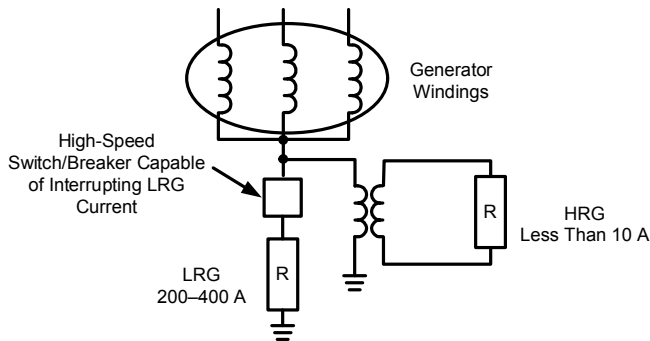

Fig. 9. Generator Grounding Methods

VI. GENERAL DISCUSSION OF GENERATOR EXCITATION CONTROL AND GENERATOR CAPABILITY

A. Excitation Control Basics

A generator excitation system provides the energy for the magnetic field (satisfying magnetizing reactance) that keeps the generator in synchronism with the power system. Present-day exciters fall into two broad categories: those using ac generators (alternators) as a power source and those using transformers.

Fig. 10 illustrates a typical transformer-supplied excitation system. In addition to maintaining synchronism of the generator, the excitation system also affects the amount of reactive power that the generator may absorb or produce. Increasing the excitation current (dc current to the field windings) will increase the reactive power output. Decreasing the excitation current will have the opposite effect and, in extreme cases, may result in loss of generator synchronism with the power

system. If the generator operates isolated from the power system and no other reactive power sources control terminal voltage, increasing the level of excitation current will increase the generator terminal voltage and vice versa.

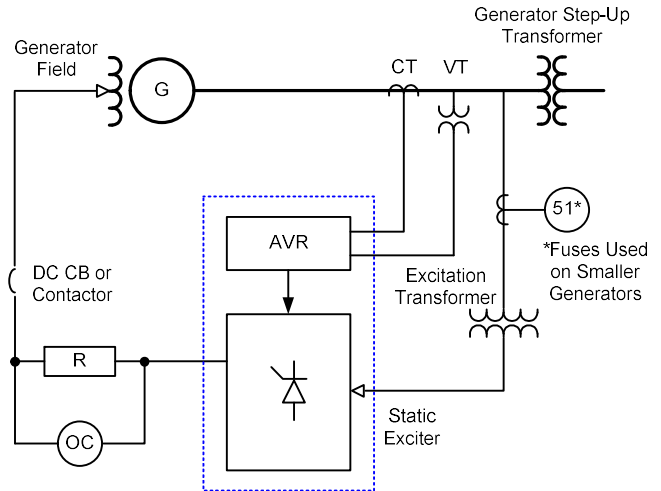

Fig. 10. Typical Transformer-Supplied Excitation System

The most commonly used voltage control mode for generators of significant size that are connected to a power system is the AVR (automatic voltage regulator) mode. In this mode, the excitation system helps to maintain power system voltage within acceptable limits by supplying or absorbing reactive power as required.

In disturbances where short circuits depress the system voltage, electrical power cannot be fully delivered to the transmission system. Fast response from the excitation system helps to increase the synchronizing torque to allow the generator to remain in synchronism with the system. After the short circuit has been cleared, the resulting oscillations of the generator rotor speed with respect to the system frequency will cause the terminal voltage to fluctuate above and below the AVR set point.

Excitation controls prevent the AVR from imposing unacceptable conditions upon the generator. These controls are the underexcitation limiter (UEL) and overexcitation limiter (OEL). The OEL prevents the AVR from supplying more excitation current than the excitation system can supply or the generator field can withstand. The OEL must limit excitation current before the generator field overload protection operates. The UEL prevents the AVR from reducing excitation to such a low level that the generator is in danger of losing synchronism, exceeding machine underexcited capability, or tripping due to exceeding the loss-of-excitation protection setting. The UEL must prevent reduction of field current to a level where the generator loss-of-field protection may operate.

B. Generator Watt/VAR Capability

The capability curve establishes steady-state (continuous) generator operating limits. The generator capability curve is normally published at generator-rated voltage. The curve also shows how the AVR control limits steady-state operation to within generator capabilities. Generator capability is a composite of three different curves: the stator winding limit, the rotor winding limit, and the stator end-iron limit (see Fig. 11).

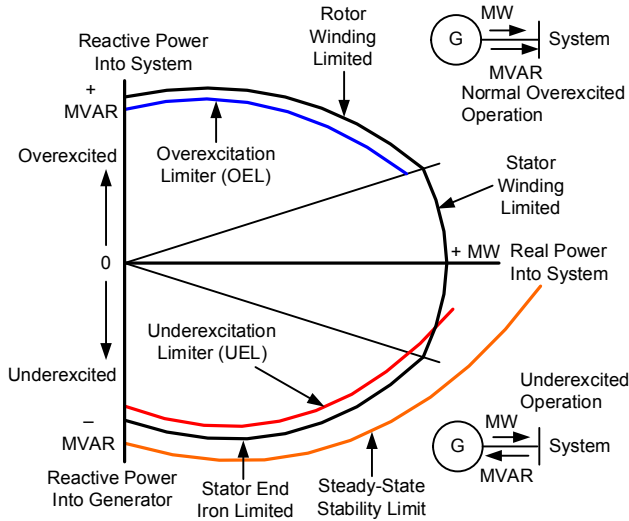

Fig. 11. Typical Generator Capability Curve and Operating Limits

The stator winding limit is a long-term condition relative to the carrying capability of the generator windings. The rotor winding limit is relative to the current-carrying capability of the rotor. It is also associated with longer time conditions. The stator end-iron limit is a relatively short time condition, caused by a reduction in the field current to the point where much of the excitation is supplied from the system to the generator. Significant generator underexcitation saturates the rotor retaining ring. The eddy currents produced by the flux cause localized heating. Hydrogen-cooled generators have multiple capability curves to reflect the effect of operating at different pressures.

The excitation control limiters are intended to limit generator operation to within its continuous capabilities. Fig. 11 illustrates how these limiter set points can be plotted on a typical generator capability curve. Generally, the UEL control setting will also be coordinated with the steady-state stability limit of the generator, which is a function of the generator impedance, system impedance, and generator terminal voltage. Section VII discusses steady-state stability in general terms and a conservative graphical method for estimating the steady-state stability limit for a generator. The OEL limits generator operation in the overexcited region to within the generator capability curve. Some users set the OEL just over the machine capability curve to allow full machine capability and to account for equipment tolerances, while others set it just under the capability curve, as shown in Fig. 11.

Engineers should be aware that more restrictive limits of generator capability could be imposed by the power plant auxiliary bus voltage limits (typically ± 5 percent), the generator terminal voltage limits (± 5 percent), and the system high-voltage bus minimum and maximum voltage during peak and light load conditions. The high- and low-voltage limits for the auxiliary bus, generator terminal, and system buses are interrelated by the tap position selected for the generator step-up (GSU) and the unit auxiliary transformers. As the power system changes, checking tap settings is necessary to ascertain that adequate reactive power is available to meet power system needs under emergency conditions.

C. P-Q to R-X Conversion

Fig. 11 shows the generator capability on a MW-MVAR (P-Q) diagram. This information is commonly available from all generator manufacturers. Generator protection functions, such as loss-of-field (40) and system backup distance (21), measure impedance; thus, these relay characteristics are typically displayed on a resistance-reactance (R-X) diagram. To coordinate the generator capability with these impedance relays, either convert the capability curve and excitation limiters (UEL and OEL) to an R-X plot or convert impedance relay settings to a P-Q plot. Fig. 12 illustrates this conversion. The CT and VT ratios (R_c/R_v) convert primary ohms to secondary quantities that are set within the relay, and kV is the rated voltage of the generator.

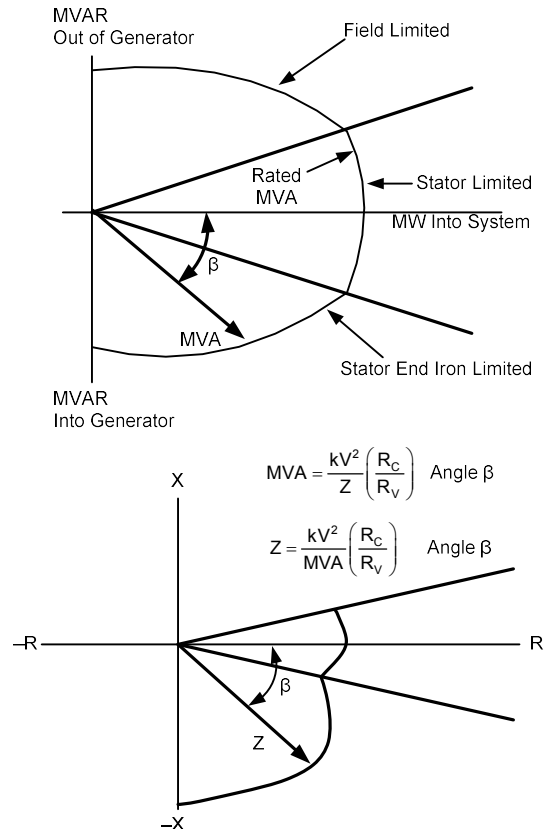

Fig. 12. Conversion From P-Q to R-X and R-X to P-Q Plots

VII. GENERATOR STABILITY BASICS

Generators that are subjected to abnormal conditions can become unstable and lose synchronism. Generator instability can be classified into three types: steady-state, transient, and dynamic.

A. Steady-State Instability

Steady-state instability occurs when too few transmission lines are available to transport power from the generating source to the load center. Fig. 13 illustrates how steady-state instability occurs. The ability to transfer real power (MW) is described by the power transfer equation and plotted graphically.

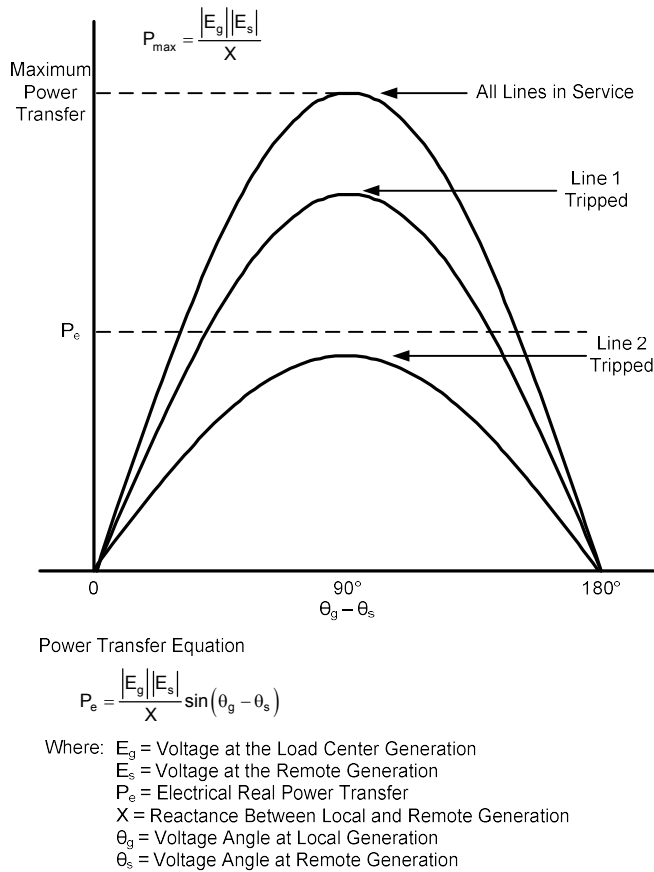

Fig. 13. Power Angle Analysis Shows Steady-State Instability

From the power transfer equation in Fig. 13, the maximum power (P_{\max}) that can be transmitted is when $\theta_g - \theta_s = 90^\circ$, i.e., $\sin 90^\circ = 1$. When the voltage phase angle between local and remote generation increases beyond 90 degrees, transmittable power is reduced. The system becomes unstable and usually splits into islands. If enough lines are tripped between the load center and the remote generation supplying it, the reactance (X) between these two sources increases, thereby reducing the maximum power (P_{\max}) that can be transferred. The power angle curve in Fig. 13 illustrates this reduction. As Line 1 trips, the height of the power angle curve and maximum power transfer is reduced because the reactance (X) between the two systems has increased. When Line 2

trips, the height of the power angle curve is reduced further to where the transferred power cannot be maintained, and the system becomes unstable.

At this point, the generator is in trouble. During unstable conditions, the power system typically breaks up into islands. If load exceeds generation within an island, frequency and voltage go down. If generation exceeds load, frequency and voltage generally go up. Steady-state instability occurs as transmission line trips increase the reactance between the load center and remote generation. Generally, a voltage drop at the load center is the leading indicator of system trouble, with low frequency occurring only after the system breaks up into islands. Major blackout analysis confirms that voltage is typically the leading edge indicator of the impending collapse of a power system.

A graphical method can determine the generator steady-state stability limit [2]. This method assumes field excitation remains constant (no AVR) and is conservative. When making the calculations, all impedances should be converted to the same MVA base, usually the generator base. The steady-state stability limit is a circle defined by the equations shown in Fig. 14.

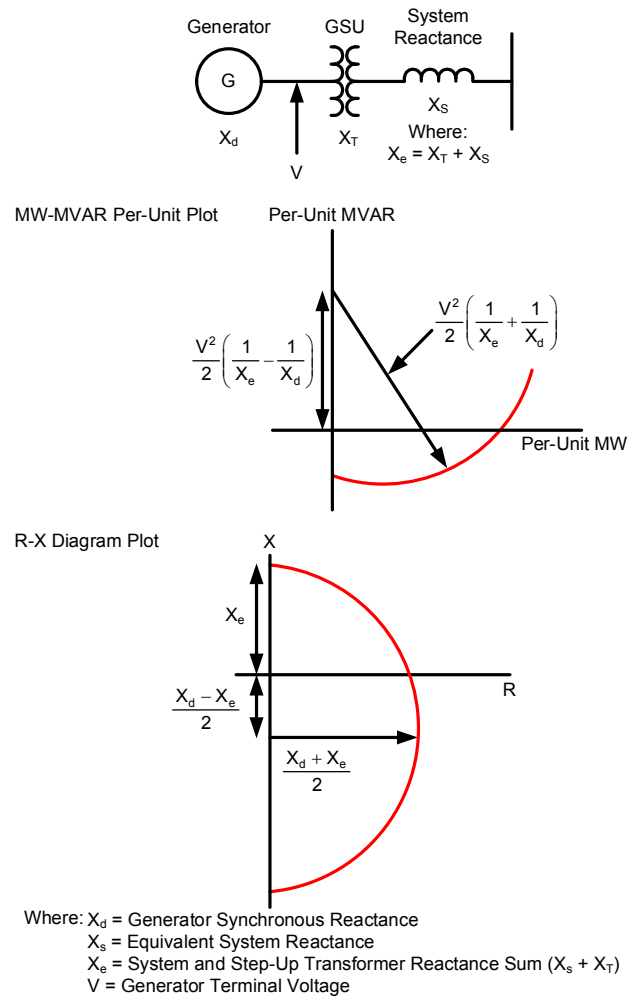

Fig. 14. Graphical Method for Steady-State Stability

The graphical method shown in Fig. 14 is widely used in the industry to display the steady-state stability limit on P-Q and R-X diagrams.

B. Transient Instability

Voltage phase angle instability can also occur because of slow-clearing transmission system faults. Called transient instability, it occurs when a fault on the transmission system near the generating plant is not cleared rapidly enough to avoid a prolonged unbalance between the mechanical and electrical generator outputs. A fault-induced transient instability has not caused any major system blackouts in recent years; however, generators need to be protected from damage that can result when transmission system protection is slow to operate. Relay engineers design transmission system protection to operate faster than a generator can be driven out of synchronism, but protection system failures have occurred that resulted in slow-clearing transmission system faults. It is generally accepted that loss-of-synchronism protection at the generator is necessary to avoid machine damage. The larger the generator, the less time it takes to drive the machine unstable for a system fault.

Fig. 15 illustrates a typical breaker-and-a-half power plant substation with a generator and a short circuit on a transmission line near the substation. If the short circuit is three-phase, very little real power (MW) will flow from the generator to the power system until the fault is cleared. The high fault current experienced during the short circuit is primarily reactive or var current. From the power transfer equation (Fig. 13), when E_g drops to almost zero, almost no real power can be transferred to the system. The generator AVR senses the reduced generator terminal voltage and increases the field current to attempt to increase the generator voltage during the fault. The AVR control goes into field-forcing mode where field current is briefly increased beyond steady-state field circuit thermal limits. During the short circuit, the generator mechanical turbine power (P_M) remains unchanged. The resulting unbalance between mechanical (P_M) and electrical power (P_e) manifests as generator acceleration, increasing its voltage phase angle, with respect to the system phase angle, as illustrated in the power angle plot in Fig. 16.

The generator acceleration rate depends on its inertia. If the transmission system fault is not cleared quickly enough, the generator phase angle will advance until the machine is driven out of synchronism with the power system. Computer transient stability studies can establish this critical switching angle and time. The equal area criteria can also be applied to estimate the critical switching angle (θ_c). When area $A_1 = A_2$ in Fig. 16, the generator is just at the point of losing synchronism with the power system. Note that after opening Breakers 1 and 2 (Fig. 15) to clear the fault, the resulting power transfer is reduced because of the increase in reactance (X) between the generator and the power system. This is due to the loss of the faulted transmission line. In the absence of detailed studies, many users establish the maximum instability angle at 120 degrees. Because of the dynamic nature of the

generator to recover during fault conditions, the 120-degree angle is larger than the 90-degree instability point for steady-state instability conditions. The time that the fault can be left on the system corresponding to the critical switching angle is called the “critical switching time.” If the fault exceeds that time, the generator will lose synchronism by “slipping a pole.” For this condition, the generator must be tripped to avoid shaft torque damage. Out-of-step protection, also called loss-of-synchronism protection (78), is typically applied on large generators to trip them, thereby protecting them from shaft torque damage and avoiding a system cascading event [5].

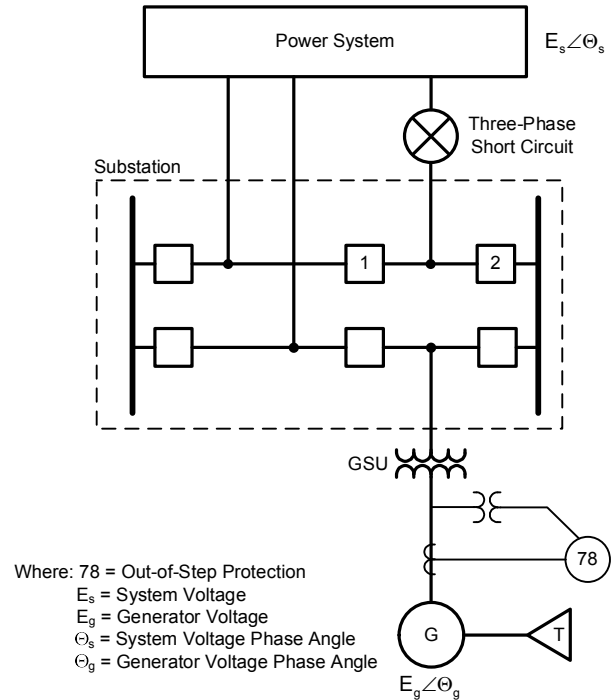

Fig. 15. Typical Breaker-and-a-Half Generating Substation One-Line Diagram

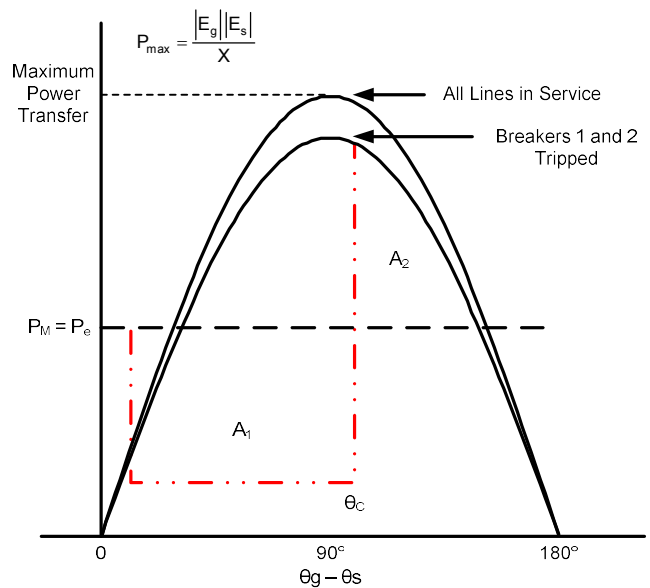

Fig. 16. Power Angle Analysis Shows Transient Instability

C. Dynamic Instability

Often associated with the western United States, dynamic instability occurs when a fast-acting AVR control amplifies rather than damps some small, low-frequency megawatt oscillations that can occur in a power system. It can, however, occur anywhere the load is remote from the generation, particularly if the system is weak. While fast-responding excitation systems are important for improving transient stability, as discussed previously, they can also contribute a significant amount of negative damping. This reduces the natural damping torque of the system, causing undamped megawatt oscillations after a disturbance, such as a system fault.

Small signal stability is defined as the ability of the power system to remain stable in the presence of small disturbances, most often caused by remote faults. Insufficient damping torque can cause generator rotor angle oscillations of increasing amplitude. When these megawatt oscillations grow, the generator can eventually be driven unstable, lose synchronism, and slip a pole. A power system stabilizer (PSS) working with the generator AVR provides positive damping when megawatt oscillations occur.

VIII. IEEE PROTECTION GUIDES

Table I lists three major IEEE guides that outline the protection requirements and practices for synchronous generators. Sponsored by the IEEE Power System Relaying

Committee, these guides provide a wealth of technical information on the electrical protection of synchronous generators.

TABLE I
MAJOR IEEE GUIDES FOR SYNCHRONOUS GENERATORS

Number	Title
C37.102	IEEE Guide for AC Generator Protection
C37.101	IEEE Guide for Generator Ground Protection
C37.106	IEEE Guide for Abnormal Frequency Protection for Power Generating Plants

IX. DEVICE NUMBERS

Device numbers concisely specify protection requirements. Numbers 1 to 100 are assigned specific definitions [6]. When discrete relays were the only method of protection, device numbers denoted a specific protective relay. With the advent of multifunction relays, these numbers now describe the functions within such relays.

Fig. 17 illustrates how some device numbers are commonly used to communicate generator protection functions. Table II lists the device numbers and their associated functions that are used for generator protection. Device number designations are referred to throughout the tutorial, so this list provides a handy reference. The definitions provided for each number relate to their application in protecting generators.

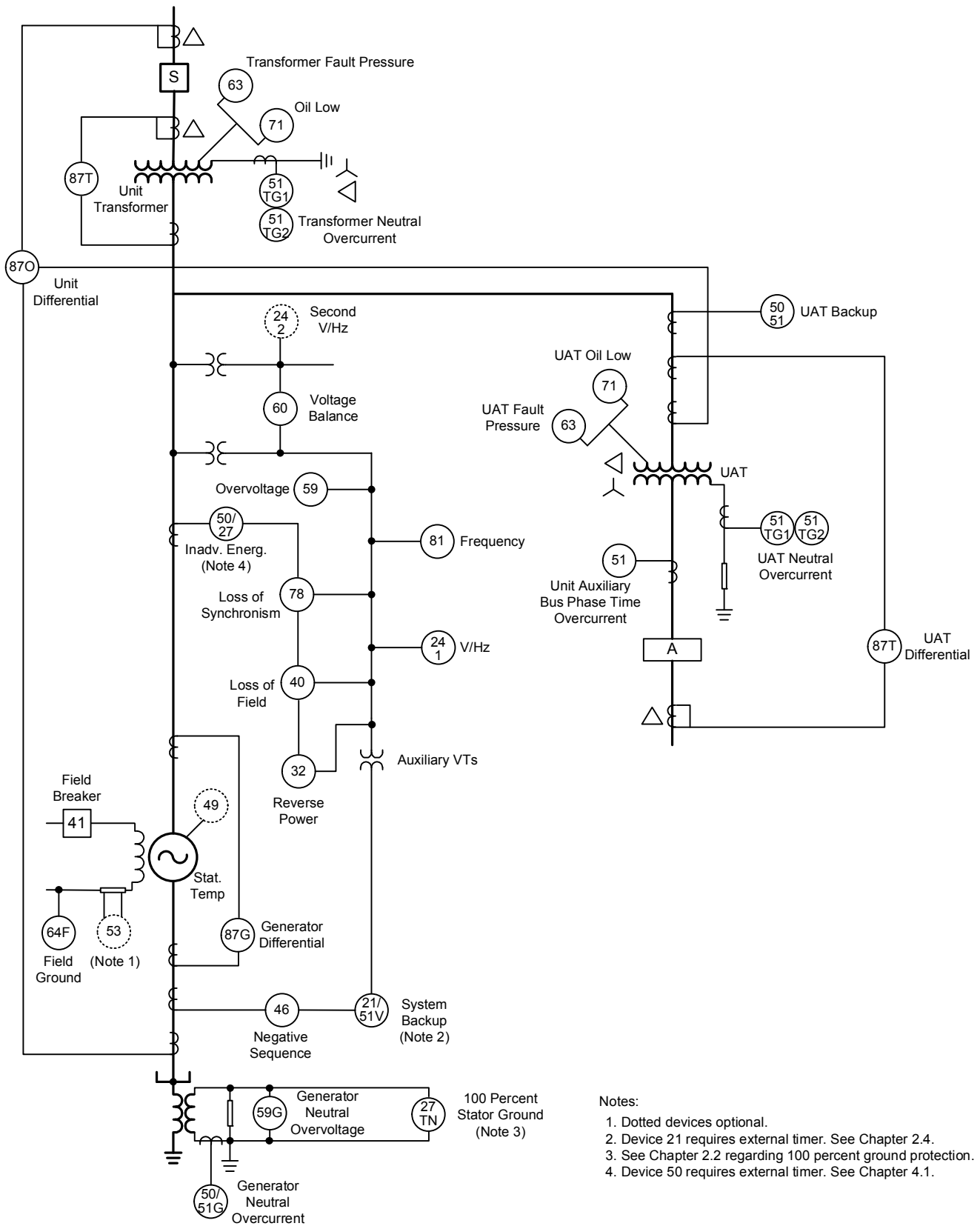

- Notes:
1. Dotted devices optional.
 2. Device 21 requires external timer. See Chapter 2.4.
 3. See Chapter 2.2 regarding 100 percent ground protection.
 4. Device 50 requires external timer. See Chapter 4.1.

Fig. 17. Typical Unit-Connected Generator Protection

TABLE II
GENERATOR PROTECTIVE DEVICE NUMBERS

Device Number	Function	Tutorial Chapter
11	Multifunction Protection System	5.2
21	Distance Relay—Backup for System and Generator Zone Phase Faults	2.4
24	Volts/Hertz Protection for Generator Overexcitation	3.2
27TN	100 Percent Stator Ground Fault Protection	2.2
32	Reverse Power Relay—Antimotoring Protection	3.5
40	Loss-of-Field Protection	3.3
46	Negative-Sequence Current Unbalance Protection for the Generator	3.4
49	Stator Thermal Protection	
51G	Time-Overcurrent Ground Relay	2.2
51TG 1&2	Backup for Ground Faults	
51V	Voltage-Controlled or Voltage-Restrained Time-Overcurrent Relay—Backup for System and Generator Phase Faults	2.4
59	Overvoltage Protection	3.2
59G	Overvoltage Relay—Stator Ground Fault Protection for a Generator	2.2
60	Voltage Balance Relay—Detection of Blown Voltage Transformer Fuses	3.7
63	Transformer Fault Pressure Relay	
62B	Breaker Failure Timer	2.5
64F	Field Ground Fault Protection	2.3
71	Transformer Oil or Gas Level	
78	Loss-of-Synchronism Protection	3.6
81	Frequency Relay—Both Underfrequency and Overfrequency Protection	3.1
86	Hand-Reset Lockout Auxiliary Relay	5.1
87G	Differential Relay—Primary Phase Fault Protection for the Generator	2.1
87N	Stator Ground Fault Differential Protection	2.2
87T	Differential Relay—Primary Protection for the Transformer	
87O	Differential Relay—Overall Generator and Transformer Protection	2.1

X. REFERENCES

- [1] J. L. Blackburn, *Symmetrical Components for Power Systems Engineering*. New York: Marcel Dekker, 1993.
- [2] W. A. Elmore, *Protective Relaying Theory and Application*. New York: Marcel Dekker, 2004.
- [3] *IEEE Recommended Practice for Protection and Coordination of Industrial and Commercial Power Systems*, IEEE Standard 242-2001.
- [4] P. Pillai, B. G. Bailey, J. Bowen, G. Dalke, B. G. Douglas, J. Fischer, J. Jones, D. J. Love, C. J. Mozina, N. Nichols, C. Normand, L. Padden, A. Pierce, L. J. Powell, D. D. Shipp, N. T. Stringer, and R. H. Young, "Grounding and Ground Fault Protection of Multiple Generator Installations on Medium-Voltage Industrial and Commercial Systems," Parts 1–4, *IEEE Transactions on Industry Applications*, vol. 40, issue 1, Jan. 2004.
- [5] *IEEE Guide for AC Generator Protection*, IEEE Standard C37.102-2006.
- [6] *IEEE Standard for Electrical Power System Device Function Numbers, Acronyms, and Contact Designations*, IEEE Standard C37.2-2008.

Stator Phase Fault Protection

Dale Finney and Sungsoo Kim

Abstract—A phase fault in a generator stator winding is serious because of the high currents encountered and the potential for damage to the machine windings, shafts, and couplings. To worsen the situation, the fault current in a faulted generator does not stop flowing when the generator field is tripped and the generator is separated from the system. The energy stored in the field will continue to supply fault current for several seconds. Repairing a severely damaged machine can be very expensive and may require long repair times that can generate high costs for replacement power until the machine is restored to service. Minimizing stator fault damage is imperative. High-speed protection on major generator units detects and quickly clears these severe faults. Rapid de-excitation methods that produce a faster decay of damaging fault currents may be justified.

I. GENERAL CONSIDERATIONS

A high-speed differential relay can detect three-phase, phase-to-phase, and double-phase-to-ground faults. Single-phase-to-ground faults are not normally detectable by differential relays on a machine unless its neutral is solidly or low-impedance grounded. When the neutral is grounded through a high impedance, the fault current is usually below the sensitivity of a differential relay.

In addition, a differential relay will not detect a turn-to-turn fault within the same phase because there is no difference in the current flowing into and out of the winding. Separate turn-to-turn fault detection on generators with two or more windings per phase will be discussed subsequently.

Normally generator stator phase fault protection does not need to be concerned with inrush (e.g., a transformer protection scheme), because the generator voltage slowly builds when the field is applied. However, energization of an out-of-zone transformer can cause problems for the generator differential, as described later.

A differential element typically measures a difference current down to about 5 percent of current transformer (CT) nominal secondary current, providing sensitive detection of internal phase faults. Thus, when applying differential protection to a generator, the principal goal is to ensure that an external fault does not produce a misoperation. The maximum fault current is dictated by the subtransient reactance, which is typically in the range of 0.12 to 0.22 pu. This results in a fault current in the range of 6 to 8 pu. Sizing a CT for this value is generally straightforward; however, the system X/R ratio at

the generator can be quite high. The resulting dc component of the fault current will decay very slowly. Because the CT flux is a function of the area under the current waveform, the CT can saturate even though the ac fault current magnitude is moderate.

When selecting CTs for the generator differential, IEEE C37.110, IEEE Guide for the Application of Current Transformers Used for Protective Relaying Purposes recommends that “the differential CTs on both sides of a generator should be of the same ratio, rating, connected burden, and preferably have the same manufacturer, so that the excitation characteristics are well matched” [1]. This recommendation ensures that the CTs saturate similarly. Small differences in the CT characteristic or in the secondary burden can produce significant differences in the CT saturation time. Spurious differential currents are at their worst when one CT begins to saturate while the other is still healthy.

When the differential zone spans the generator breaker, the CTs are more likely to be dissimilar because they may have been supplied by different manufacturers. It should be stressed that using the same standard accuracy CTs does not guarantee the same characteristics. Furthermore, because the relay is often installed adjacent to the generator breaker, the secondary leads may be much shorter than those of other CTs installed in the neutral side of the generator CT.

Calculation of time-to-saturate is a practical way to assess CT performance. If an external fault is cleared by downstream protections prior to saturation, the generator differential should not be compromised. Energization of an out-of-zone transformer can cause problems for the generator differential. This is due to the large dc component and long time constant of the inrush current. The phenomenon is essentially the same as that of the external fault case except that in this case the current is not cleared by downstream protections. Some relay manufacturers have developed algorithms intended to improve security for saturation of mismatched CTs. Other manufacturers provide CT oversizing formulas that consider the differential algorithm behavior.

II. TYPES OF DIFFERENTIAL SCHEMES

Three high-speed differential schemes are used for stator phase fault detection: percentage differential, high-impedance differential, and self-balancing differential schemes.

A. Percentage Differential Scheme

The percentage differential scheme achieves security during external faults by employing a restraining signal to bias the operating signal. The operating signal is usually the vector sum of the two CT currents, and the restraining current is usually the average magnitude of the two CT currents. The ratio of the operating signal and restraint signal (slope) may be variable, fixed, or dual slope. See Fig. 1 and Fig. 2. In a variable differential relay, the slope may vary from 5 to 50 percent or more. The slope of the fixed-percentage relay is usually fixed at 10 to 25 percent. In the dual slope relay, Slope 1 is adjustable and set to account for error occurring when the CTs are operating in their linear (nonsaturated) regions. Slope 2 may be fixed or adjustable and is intended to account for error occurring when the CTs are operating in their saturated regions. These relays usually have a minimum pickup setting that is typically set in the 5 to 10 percent (CT nominal) range. A typical scheme using a percentage differential relay is shown in Fig. 3.

B. High-Impedance Differential Scheme

The high-impedance differential scheme employs a stabilizing resistor to provide security for CT saturation during an external fault. The relay is actually a voltage relay and responds to high voltage impressed across its coil, caused by the CTs all trying to force current through the operate winding during an internal fault. These relays should be supplied from identical CTs with fully distributed secondary windings with negligible leakage reactance. The setting of the high-impedance relay is based on the perfect performance of one input CT and the complete saturation of the others.

For very high currents in large generators, the proximity of CTs in different phases to each other can cause unbalanced currents to flow in the CT secondaries. These currents must be less than the minimum sensitivity of the differential relay used. Normally the supplier considers this condition in the unit design, but it should also be checked.

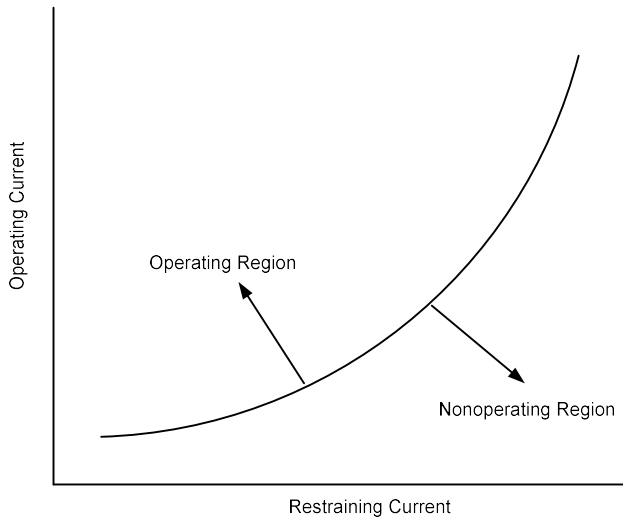

Fig. 1. Variable Slope Percentage Differential Relay

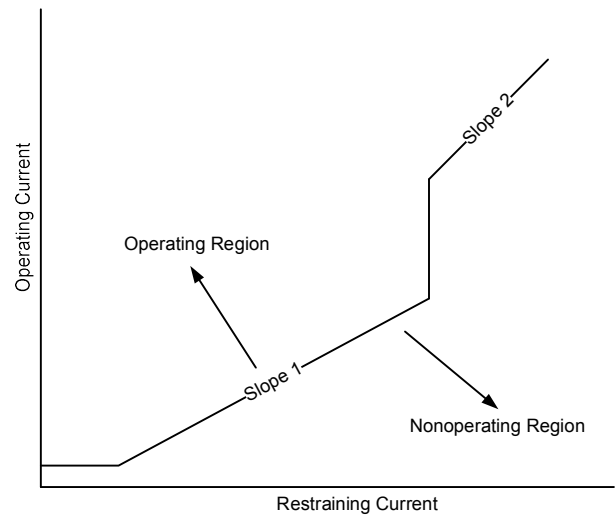

Fig. 2. Dual Slope Percentage Differential Relay

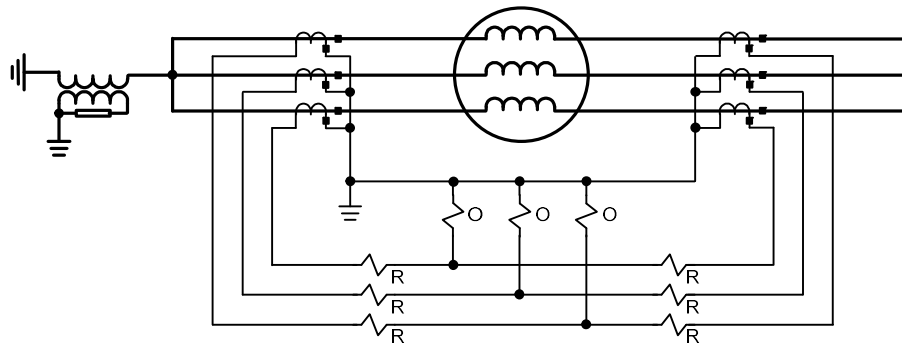

Fig. 3. Percentage Differential Relay Connection: Six-Bushing, Wye-Connected Generator

C. Self-Balancing Differential Scheme

The self-balancing differential scheme, as shown in Fig. 4, typically is used on small generators. This scheme detects phase and ground faults on the generator stator using a single low-ratio CT per phase with the leads of both ends of each winding passing through it, so the net flux is zero for normal conditions. A simple instantaneous overcurrent relay connected to the CT secondary provides fast, reliable protection by detecting any difference between current entering or leaving the winding. The limited size of the CT window limits conductor size and consequently the size of the unit that can be protected. Saturation for external faults is not a concern, but saturation during internal faults is possible. The relay should have as low a burden as possible, typically solid state, to maintain high sensitivity and lessen the likelihood of CT saturation. Very high fault currents can saturate this type of CT if a sensitive electromechanical relay with high burden is used.

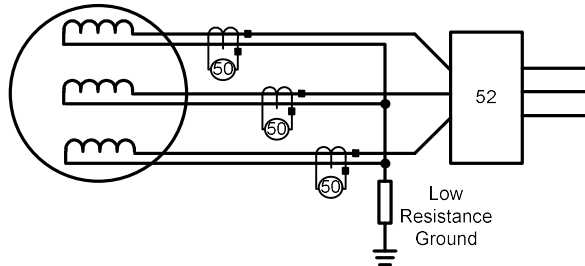

Fig. 4. Self-Balancing Protection Scheme

III. TURN-TO-TURN FAULT PROTECTION

A. Basic Split-Phase Relay Scheme

Phase differential protection (87) will not detect a turn-to-turn fault occurring on the same phase unless the fault develops into a phase-to-phase or phase-to-ground fault over time, which will eventually trigger the operation of phase differential (87) or ground protection (59G), respectively. But by the time 87 or 59G element operates, it may be too late, as severe stator damage would have already occurred.

The split-phase relay scheme can detect turn-to-turn faults, but it requires that the stator windings split into two equal groups per phase, as shown in Fig. 5. Most low-speed hydroelectric generators in North America are constructed with two or more circuits per phase, each circuit having multiturn coils. When a coil is short circuited, as shown in Fig. 5, a voltage unbalance occurs, which in turn causes circulating current to flow between the windings of the faulted phase. It is typical to install an individual overcurrent relay with instantaneous and very-inverse characteristics per each phase to detect the circulating current.

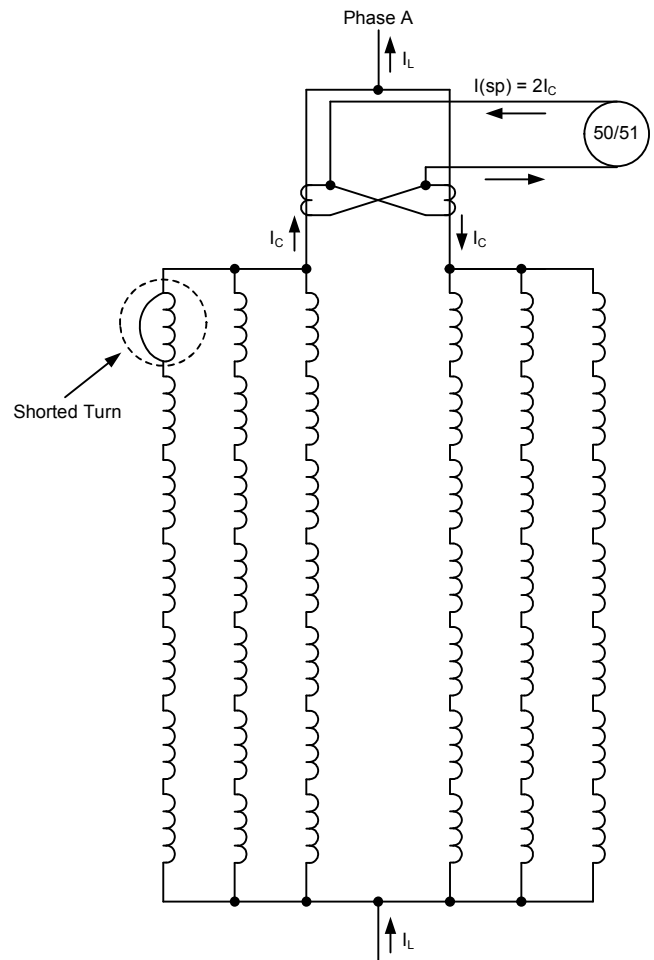

Fig. 5. Split-Phase Current Due to Shorted Turn on Phase A

Fig. 6 illustrates the split relay scheme using six separate bushing-type CTs. Each phase consists of two differentially connected CTs, with their output terminals connected to a single overcurrent relay. The purpose of the overcurrent relay is to measure a difference of the currents, I_1 and I_2 . This scheme, however, may not provide the desired sensitive settings because there may exist higher-than-normal unbalanced current under normal operating condition because of unequal CT characteristics between the two CTs.

CT error currents that are expected with the arrangement shown in Fig. 6 are eliminated by using single or double window CTs, as shown in Fig. 7 and Fig. 8. The elimination of CT errors allows a more sensitive setting on the instantaneous relay. The single window CT in Fig. 7 is usually limited to small generators because of the size of the window, which requires smaller conductor cables. The double window CT in Fig. 8 is used for larger generators.

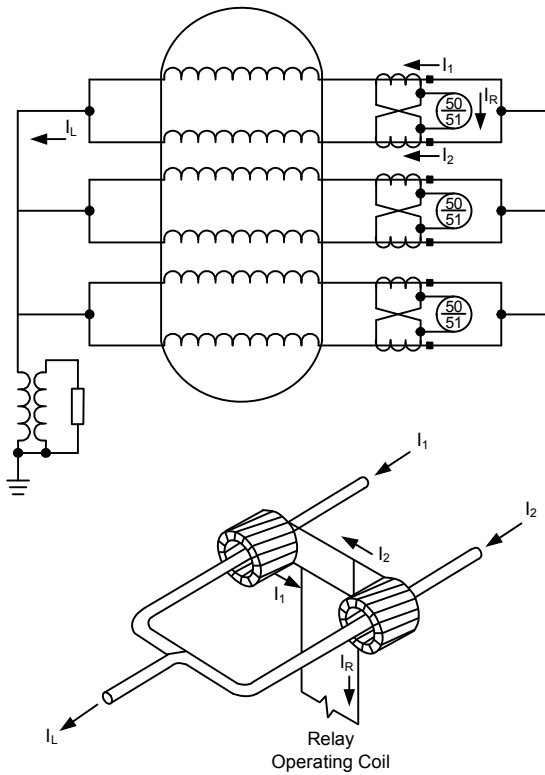

Fig. 6. Split-Phase Protection Using Separate CTs [2]

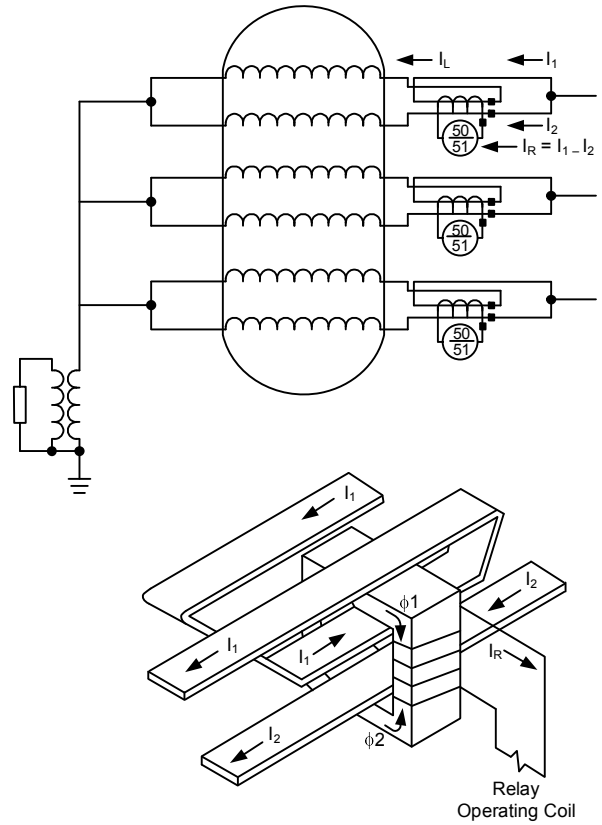

Fig. 7. Split-Phase Protection Using Single Window CTs [2]

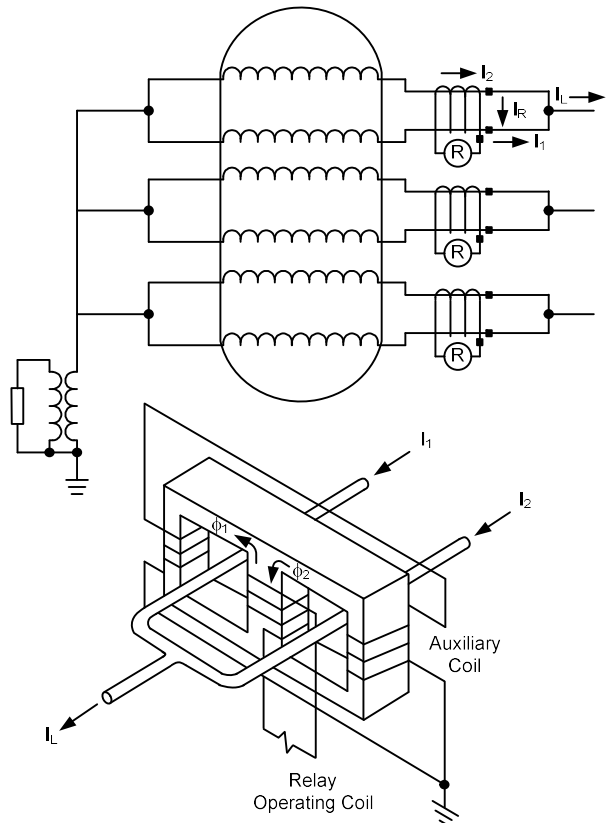

Fig. 8. Split-Phase Protection Using Double-Primary, Single-Secondary CTs [2]

B. Split-Phase Current Variations and Measurements

Ideally under normal conditions, no circulating currents should exist in the parallel windings. But in reality, there always exists a certain amount of circulating current that flows in the parallel windings because of the following factors:

- imperfection in the generator construction
- temperature variations
- winding connections
- external faults
- terminal voltage and load variations

All of these factors make it difficult to determine proper settings values. To apply proper split-phase settings values, normal circulating currents need to be measured by field tests and regularly checked, because normal circulating currents are continuously varying over time, changing from season to season or over day and night due to temperature variations. The following should be considered when split-phase current is measured in the field:

- Split-phase current naturally exists in the stator windings. Measurement of the highest split-phase current is usually found at maximum operating voltage and current but can also occur when there is no-load current with high voltage.
- The generator manufacturer should provide data on the value of minimum split-phase current for a single shorted turn, which is typically 4 percent of generator full load current. The minimum split-phase current occurring during a single shorted turn can be assumed to be twice the split-phase current, I_{sp} , which occurs during the normal condition.
- A staged, three-phase fault test should be conducted at reduced voltage to determine the maximum split-phase current under external fault condition. The prediction of the split-phase current can thus be determined through linear extrapolation to full load voltage.

C. Settings

In general, the relay should be set above any normal unbalanced current but below the unbalance caused by a single shorted turn. Sometimes under emergency conditions, the generator is allowed to operate with a cutout coil, but the

amount of cutout coil should be limited to 10 percent of the winding. The time delay for the protection should be set to prevent operation that may occur during external faults caused by unequal CT response to the transient. The instantaneous unit must also be set above the transient level expected during external faults and consequently will likely detect multiterminal and phase-to-phase faults only.

1) Time Element

The minimum pickup current setting for the time element should be selected at 1.5 times the magnitude of the maximum split-phase current measured under the normal operating condition, $I_{min} = 1.5 \cdot I_{sp}$. If the normal split-phase currents from all three phases are reasonably close to one another, the same setting can be applied for all three relays. This setting value should be based on the highest measured I_{sp} . However, if the split-phase current of one (or two) phase(s) is unusually high compared with the other phases, individual phase settings need to be applied. In this case, three independent relay elements are required for split-phase protection.

The time dial setting should be chosen so that the relay will operate in approximately 0.5 seconds at two times I_{min} . This is a reasonable choice, as the split-phase current can go up to four times I_{sp} during external fault conditions.

2) Instantaneous Element

An instantaneous pickup setting should be chosen approximately at $I_{inst} = 7 \cdot I_{min}$, which is based on a subtransient fault current, $I'' = 1/X''g$ pu, during which time the split-phase current may reach up to five to seven times I_{min} . The setting is set high so that the instantaneous overcurrent element does not react to external faults during the subtransient period. It also provides backup protection to generator differential protection.

3) Trip

The split-phase protection, if operated, initiates a complete shutdown of the generator and locks out. The lockout feature is needed for further inspection of damage to the windings before the generator is brought back to service. A turn-to-turn fault can cause a fire, for which a deluge operation is required. The deluge should operate only if such fire detecting apparatus as HAD (heat activating device) is triggered. It will also initiate the closure of louvers to starve oxygen in the generator chamber.

D. Turn-to-Turn Stator Fault Detection Using Unbalanced Overvoltage (59N)

For generators whose stator winding is not split for the application of a split-phase current differential scheme, a neutral unbalanced voltage detection method may be used, as shown in Fig. 9. The scheme requires a single-phase voltage relay connected to an “open corner delta” of the VT (voltage transformer) secondary side. However, the primary-side VTs are connected in wye, with the neutral connection point tied to the generator neutral instead of station ground. The connection of the wye neutral point to the generator neutral will make the 59N relay insensitive to a stator ground fault. The relay, however, will operate for a turn-to-turn fault, which will cause the unbalanced voltage to go above and beyond the normal level of the unbalance that normally exists across the open corner delta.

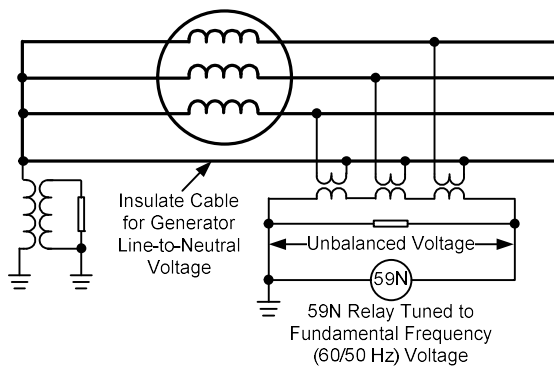

Fig. 9. Turn-to-Turn Stator Winding Fault Protection, Zero-Sequence Overvoltage Method (59N) [2]

The installation requires a cable lead from the generator neutral to the VT neutral because the VTs are located at the generator terminal. In addition, the cable insulation should be rated for the system line-to-ground voltage. One drawback of this scheme is a solid generator ground if the line-to-neutral insulated cable that connects the VT neutral to the generator neutral sustains a ground fault. For this reason, periodic testing of the cable is recommended.

The 59N relay is tuned to fundamental frequency (60/50 Hz) voltage because some third-harmonic voltages will be present across the broken-delta VT input.

Note that this scheme is more widely accepted outside the United States.

IV. BACKUP PROTECTION

The most common type of backup protection used for unit-connected generator stator phase faults is the overall differential relay. For smaller units or units connected directly to a bus, system backup and negative-sequence relays, discussed in a separate section of the tutorial, are used. Also, an impedance relay is sometimes used to provide backup protection for the generator step-up (GSU) transformer and generator.

A. Overall Differential Protection

The overall differential provides backup protection for both the generator and step-up transformer, as shown in Fig. 10. A harmonically restrained transformer differential relay is applied. The generator auxiliary transformer may also be included in the differential zone as shown. The high CT ratio required on the low-voltage side of the auxiliary transformer to balance the differential circuit currents may require the use of an auxiliary CT. It is usually preferable to include the auxiliary transformer inside the overall differential if possible. The CTs on the high side of the auxiliary transformer that feed the auxiliary transformer differential circuit may severely saturate for high-side faults because of the extremely high fault current at that point. Saturation could be so severe that the differential relay might fail to operate, resulting in a failure to trip. The overall differential connected to the auxiliary transformer low-voltage side would detect the fault and provide backup tripping.

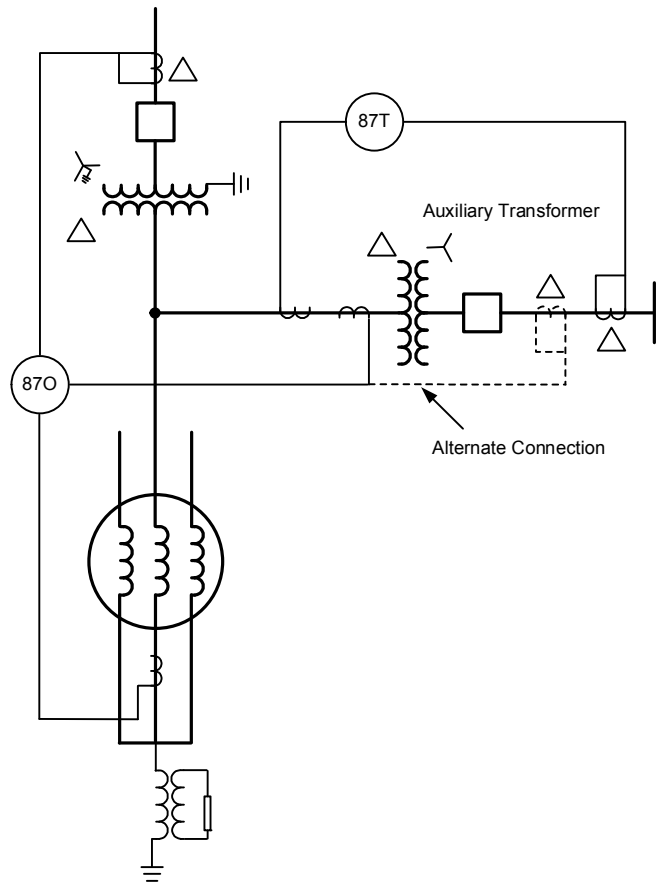

Fig. 10. Generator Phase Fault Backup Overall Differential Scheme

When applying overall differential protection to a cross-compound generator, it is acceptable to parallel CTs in the neutral side of the generator or connect them to separate windings of a multiwinding differential relay.

B. Impedance Protection

Impedance protection can provide backup protection for phase-to-phase and three-phase faults on the stator or isolated phase bus outside of the generator differential zone. Impedance protection is preferable to overcurrent protection because the sustained fault current may be less than the load value. The element may have an impedance characteristic centered at the origin or have an offset mho characteristic. It may be connected to the generator neutral CTs, in which case the reach should be set to cover a portion (50 percent) of the GSU transformer impedance with little or no intentional time delay. Alternately, the element may be connected to a CT at the generator terminals or on the high-voltage side of a GSU transformer looking back toward the generator. If connected at the high-voltage side of a GSU transformer, then it also provides protection for faults in the GSU transformer. In this case, the element will not operate if the generator is offline.

V. REFERENCE

- [1] *IEEE Guide for the Application of Current Transformers Used for Protective Relaying Purposes*, IEEE Standard C37.110-2007.
- [2] *IEEE Guide for AC Generator Protection*, IEEE Standard C37.102-2006.

Stator Ground Fault Protection

Wayne Hartmann and Joe T. Uchiyama

Abstract—This part of the tutorial deals with generator stator neutral grounding and the protection schemes used to detect stator ground faults. Two types of grounding methods, high- and low-impedance, are described. These methods represent the major practices used within the industry to ground generator stator windings. In addition, predominant protection schemes are also described.

I. INTRODUCTION

The stator grounding method used in a generator installation determines the generator performance during ground fault conditions. If the generator is solidly grounded, it will deliver a very high-magnitude current to a single-line-to-ground (SLG) fault at its terminals, accompanied by a 58 percent reduction in the phase-to-phase voltages involving the faulted phase and a modest neutral voltage shift. If the generator is ungrounded, it will deliver a negligible amount of current to a bolted SLG fault at its terminals, accompanied by no reduction in the phase-to-phase terminal voltages and a full neutral voltage shift. These conditions represent the extremes in generator grounding, with normal practice falling predictably in between. In practice, generators are rarely operated solidly grounded or ungrounded, with the possible exception of low-voltage systems.

A high magnitude of fault current is available when a generator is solidly grounded. This is not acceptable because equipment damage will be severe. Furthermore, shutting down the generator by tripping the generator breaker, excitation (field) breaker, and prime mover does not cause the fault current to immediately go to zero. The flux trapped in the field will result in the fault current slowly decaying over a number of seconds after the generator is tripped, which can cause substantial damage.

At the other extreme, operating an ungrounded generator provides negligible fault current, but the line-to-ground voltages on the unfaulted phases can rise considerably during ground faults, which could cause the failure of generation equipment insulation. As a result, stator windings on major generators are grounded in a manner that will reduce fault current and overvoltages and yet provide a means of detecting the ground fault condition quickly enough to prevent burning of core iron. Two types of grounding are widely used within the industry. They are categorized as high- and low-impedance grounding. An emerging method known as hybrid grounding is also used as an alternative solution.

II. LOW-IMPEDANCE STATOR GROUNDING

The low-impedance stator grounding method is illustrated in Fig. 1, Fig. 2, and Fig. 3.

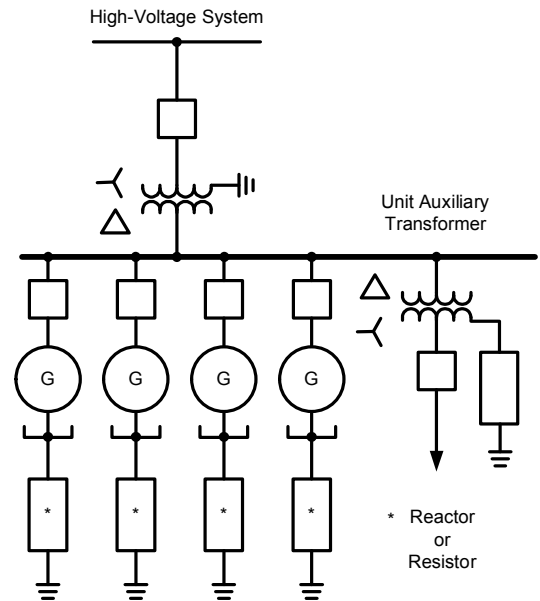

Fig. 1. Generators Bussed Together on a Common Bus Sharing a GSU (Generator Step-Up) Transformer [1]

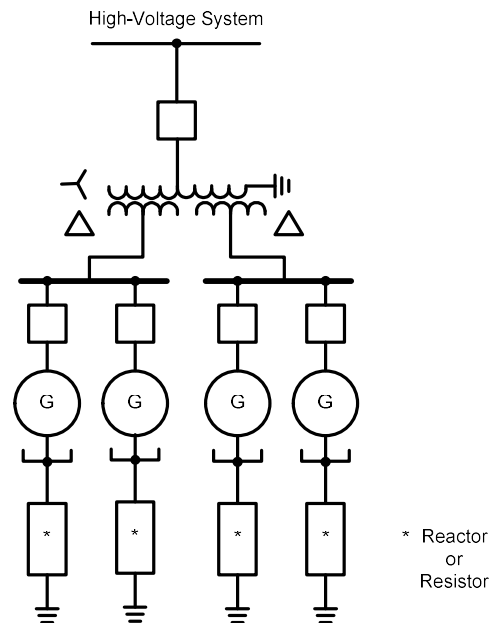

Fig. 2. Groups of Bussed Generators Sharing GSU Secondary Windings [1]

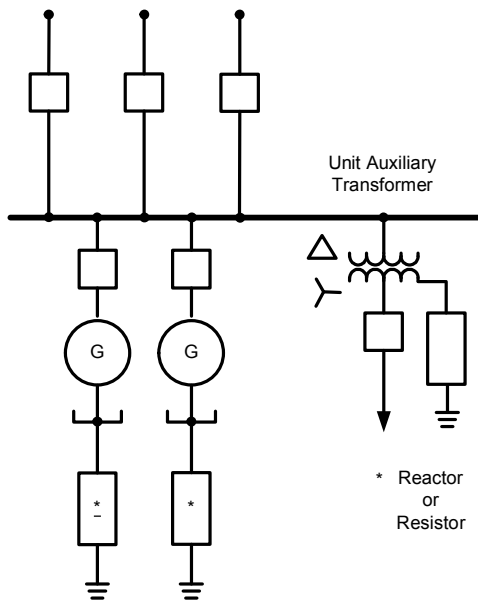

Fig. 3. Generators Connected Directly to a Distribution System Bus [1]

The grounding resistor or reactor is selected to limit the generator contribution to an SLG fault to a range of currents generally between 200 amperes and 150 percent of rated load current. With this wide range of available fault current, phase differential relaying can provide some ground fault protection for higher levels of ground fault currents. However, the differential relay will not provide ground fault protection for the entire stator winding. Supplemental protection is commonly provided. Fig. 4 is an illustration of a ground differential scheme that provides this enhanced sensitivity. This scheme, employing ground differential protection, is fully described in [2]. The relay is connected to receive residually derived neutral current from the generator terminals as one input and the generator ground current as the other input.

The biased differential comparison ensures that a positive restraint exists for an external fault even though the current transformers (CTs), R_{CN} and R_{CL} , have substantially different performance characteristics. This scheme provides excellent security against misoperation for external faults and provides very sensitive detection of internal ground faults. A similar scheme using a digital relay is possible without the need for an auxiliary CT.

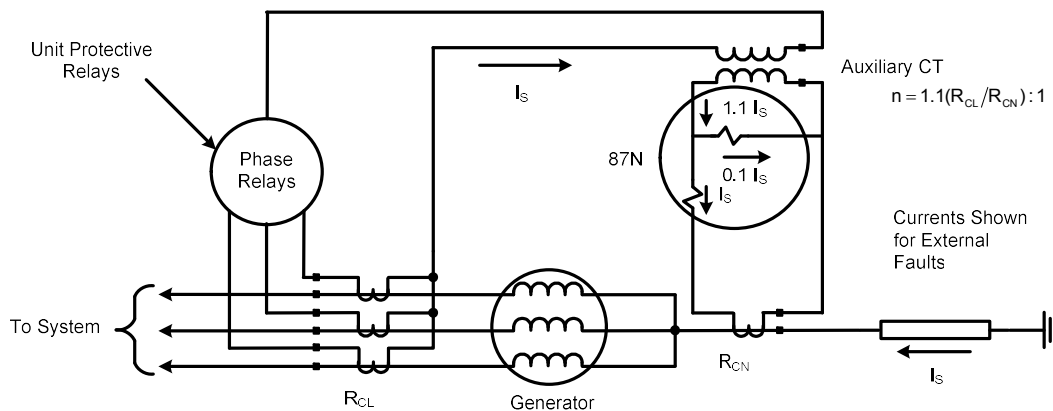

Fig. 4. Generator Ground Differential Using a Product-Type Relay [1]

III. HIGH-IMPEDANCE STATOR GROUNDING

High-resistance generator neutral grounding is illustrated in Fig. 5. This scheme is primarily used on unit-connected systems having a GSU transformer with windings connected delta on the generator side and grounded-wye on the system side; however, it can also be used on cross-compound generators where one winding is generally high-impedance grounded.

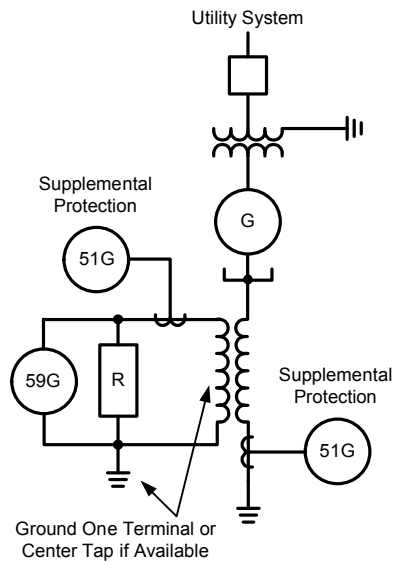

Fig. 5. High-Impedance Grounded Generator [1]

High-resistance generator neutral grounding uses a distribution transformer with a primary voltage rating greater than or equal to the line-to-neutral voltage rating of the generator and a secondary rating of 120 or 240 V. The distribution transformer should have sufficient overvoltage capability so that it does not saturate on SLG faults with the machine when operated at 105 percent of rated voltage. The secondary resistor is usually selected so that, for an SLG fault at the generator terminals, the power dissipated in the resistor is approximately equal to the reactive volt-amperes in the zero-sequence capacitive reactance of the generator windings, its leads, and the windings of any transformers connected to the generator terminals. Using this grounding method, an SLG fault is generally limited to 3 to 25 primary amperes. As a result, this level of fault current is not sufficient to operate generator differential relays. The Appendix provides a detailed example of how to determine the size of the ground resistor to meet the requirements cited previously as well as calculate the resulting ground currents and voltages.

IV. CONVENTIONAL HIGH-IMPEDANCE STATOR WINDING PROTECTION METHODS—NEUTRAL OVERVOLTAGE/OVERCURRENT SCHEME

The most widely used protection scheme in high-impedance grounded systems is a time-delayed overvoltage relay (59G) connected across the grounding resistor to sense zero-sequence voltage $3V_0$, as shown in Fig. 5. The relay used for this function is designed to be sensitive to fundamental

frequency voltage and insensitive to third-harmonic and other zero-sequence harmonic voltages that are present at the generator neutral.

Since the grounding impedance is large compared to the generator impedance and other impedances in the circuit, the full phase-to-neutral voltage will be impressed across the grounding device for a phase-to-ground fault at the generator terminals. The voltage at the relay is a function of the distribution transformer ratio and the location of the fault. The voltage will be a maximum for a terminal fault and decreases from the generator terminals toward the neutral. Typically, the overvoltage relay has a minimum pickup setting of approximately 5 V. With this setting and with typical distribution transformer ratios, this scheme is capable of detecting faults to within approximately 5 percent of the stator neutral.

The time setting for the overvoltage relay is selected to provide coordination with other system protective devices. Two specific areas of concern are VT (voltage transformer) connection and coordination with other relays.

A. VT Connection

When grounded wye-grounded wye VTs are connected at the machine terminals, the neutral ground overvoltage relay should be coordinated with VT transformer fuses to prevent tripping the generator for VT secondary ground faults. If the relay time delay is not acceptable, the coordination problem can be alleviated by grounding one of the secondary phase conductors instead of the secondary neutral. Thus, a secondary ground fault results in a phase-to-phase VT fault, which will not operate the neutral ground overvoltage relay. However, when this technique is used, the coordination problem still exists for ground faults on the secondary neutral; thus, its usefulness is limited to those applications where the exposure on secondary neutral-to-ground faults is small.

B. Coordination With Other Relays

The voltage relay may have to be coordinated with system relaying for system ground faults. System phase-to-ground faults induce zero-sequence voltages at the generator neutral due to capacitive coupling between the windings of the unit transformer. This induced voltage appears on the secondary of the grounding distribution transformer and can cause operation of the zero-sequence voltage relay.

A time-overcurrent relay can be used as backup protection when the generator is grounded through a distribution transformer with a secondary resistor. The CT supplying the overcurrent relay may be located either in the primary neutral circuit or in the secondary circuit of the distribution transformer, as shown in Fig. 5. When the CT is connected in the distribution transformer secondary circuit, a CT ratio is selected so that the relay current is approximately equal to the maximum primary current in the generator neutral. An inverse-time or very inverse-time delay overcurrent relay is generally used for this application. The pickup setting of the overcurrent relay should be no less than 135 percent of the maximum value of current measured in the neutral under

nonfault conditions. In general, the overcurrent relay provides less sensitive protection than the overvoltage relay that detects zero-sequence voltage. As with the overvoltage relay, the overcurrent relay must be coordinated with the VT fuses and with the system ground relaying.

V. 100 PERCENT STATOR WINDING GROUND FAULT PROTECTION METHODS

Conventional protection for stator ground fault detection on high-impedance grounded systems was discussed in Section IV. These protective schemes are straightforward and dependable; however, these relays can provide protection for only about 80 to 95 percent of the stator windings. This is due to generator construction imperfections and the subsequent small amounts of zero-sequence current that will flow in the generator ground. This small amount of zero-sequence current makes it impossible for conventional ground fault detection relays to remain selective when set too low. It is important to protect major generators with an additional ground fault protection system so that fault coverage for 100 percent of the winding is obtained. The techniques for detection of ground faults that cover 100 percent of stator windings can be divided into three categories:

- Third-harmonic voltage-based techniques
- Neutral or residual subharmonic voltage injection

A. Third-Harmonic Voltage-Based Techniques

Third-harmonic voltage components are present at the terminals of nearly every machine to varying degrees; they arise due to the nonsinusoidal nature of rotor flux and vary based on the differences in design and manufacture. If present in a sufficient amount, this voltage is used by the schemes in this category to detect ground faults near the neutral. The third-harmonic voltages measured at the generator neutral or terminals or both are used to provide protection. Before discussing the techniques and their operation, it is worthwhile to look at the characteristic of third-harmonic voltages, which these schemes use as their relaying signals for fault detection. Fig. 6 shows the third-harmonic voltages (V_3RD) present at the neutral and terminals of a typical generator during different load conditions: (a) under normal operation, (b) for a fault at the neutral end, and (c) for a fault at the generator terminals.

The following observations can be made from Fig. 6:

- The level of third-harmonic voltage at the neutral and generator terminals is dependent on the operating conditions of the generator. The voltage is usually higher at full load than at no load as depicted in Fig. 6, except when generators are operated as underexcited synchronous condensers.
- There is a point in the windings, typically near the middle, where the third-harmonic voltage is zero. The exact position of this point depends on operating conditions and generator design.

- As the fault position approaches the generator neutral, the third-harmonic voltage at the neutral decreases, and it increases at the terminals. For a ground fault at the neutral, the third-harmonic voltage at the neutral becomes zero.
- As the fault position approaches the generator terminals, the third-harmonic voltage at the terminals decreases while increasing at the neutral. For a ground fault at the terminals, the third-harmonic voltage at the terminals becomes zero.
- The level of third-harmonic voltage varies from one machine to another depending on the design. The third-harmonic levels of any generator should be measured with the generator connected and disconnected from the unit transformer before enabling any third-harmonic-based protection schemes. This is done to ensure that adequate third-harmonic voltage levels exist to operate the protective elements during all expected loading conditions.

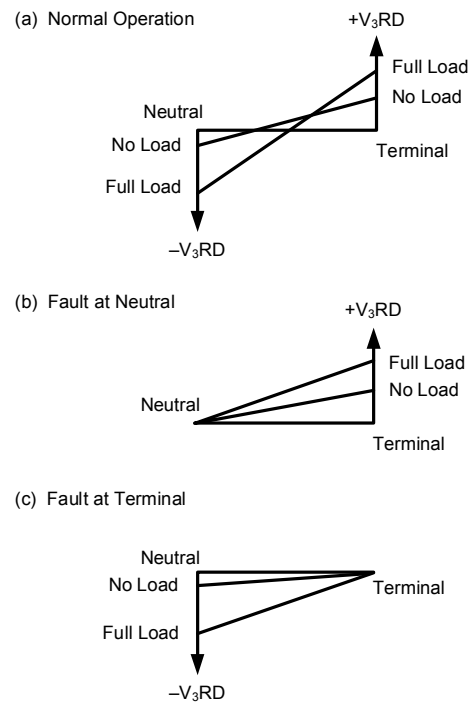

Fig. 6. Third-Harmonic Voltage for Different Conditions in a Typical Generator [1]

Third-harmonic voltage-based techniques include:

- Third-harmonic neutral undervoltage technique [3]
- Third-harmonic residual terminal overvoltage technique [1]
- Third-harmonic comparator (differential) technique [4]

1) Third-Harmonic Undervoltage Technique

This technique uses the fact that for a fault near the neutral, the level of third-harmonic voltage at the neutral decreases. Therefore, an undervoltage relay operating from third-harmonic voltage measured at the neutral end could be used to detect the faults near the neutral. Ground faults in the remaining portion of the windings can be detected by conventional ground fault protection, e.g., an overvoltage relay (59G), which operates on the 60 Hz neutral voltage. The combination of both relays provides 100 percent stator winding protection. A simplified protection scheme using this technique is shown in Fig. 7.

The relay signals are taken from voltage inputs measured across the neutral resistor. Overvoltage protection uses the 60 Hz (fundamental) tuned overvoltage level detector (59G) and a timer. This protection is supplemented by an undervoltage protection, which uses the 180 Hz (third harmonic) tuned undervoltage (27N3) level detector and a timer.

The settings for the third-harmonic undervoltage element and the fundamental overvoltage and/or overcurrent element are derived to overlap coverage, so 100 percent stator winding ground fault coverage is achieved.

The third-harmonic undervoltage relay must be blocked to avoid false tripping during generator shutdown or startup. A supervisory overvoltage (59C) relay can provide this protection.

Normally, the third-harmonic undervoltage protection can provide adequate protection for 0 to 30 percent of the stator winding measured from the neutral toward the machine terminal. The undervoltage relay setting should be well below the minimum third-harmonic voltage present at the neutral during expected real and reactive power loading of the machine.

In some cases, the generator does not develop significant third-harmonic voltage until it is loaded. In this case, supervision using an overcurrent relay can be provided. The overcurrent relay operates when the current exceeds its pickup value; therefore, under light load conditions and when the main breaker is open, the third-harmonic undervoltage relay is blocked from operation. Other supervision such as real power, reactive power, and breaker contact may also be employed. Third-harmonic tuned undervoltage protection operates for open and short circuits of primary or secondary windings of the neutral grounding transformer but is not able to detect an open circuit in the secondary grounding resistance.

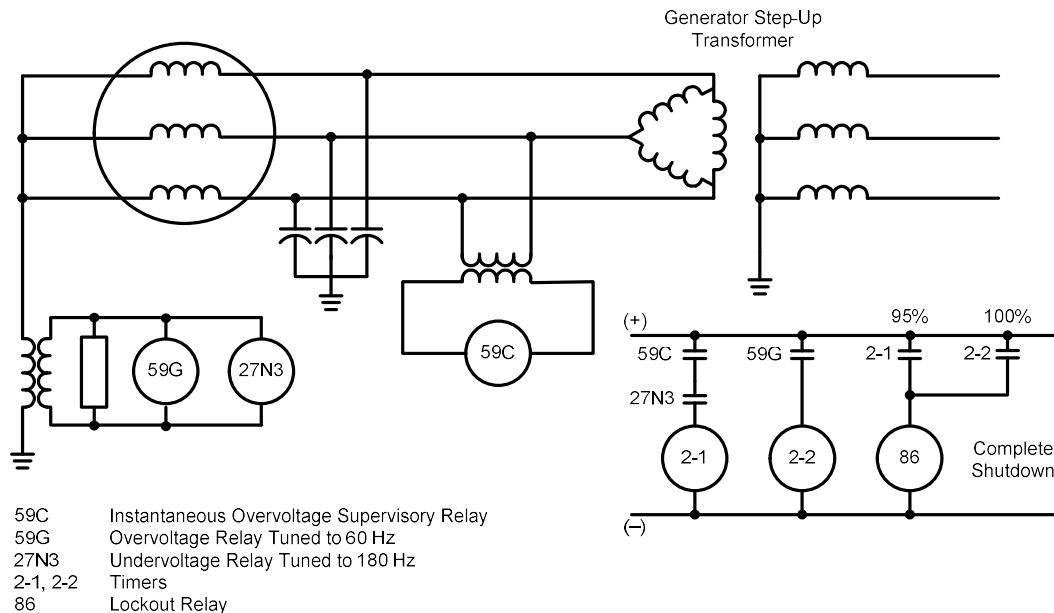

Fig. 7. A Third-Harmonic Undervoltage Ground Fault Protection Scheme [1]

2) Third-Harmonic Residual Terminal Voltage Technique

This technique is based on the fact that for a fault near the neutral, the level of third-harmonic overvoltage (59T) at the generator terminals increases. Therefore, an overvoltage relay using third-harmonic voltage (59T) at the terminals of a generator can be used for detecting faults near the neutral. As before, ground faults in the remaining portion of the windings can be detected by the conventional 95 percent protection, e.g., an overvoltage relay (59G) that operates on 60 Hz neutral voltage. Using both of these relays (59G and 59T) would provide 100 percent protection of stator windings by covering different portions of the windings. A simplified protection scheme using this technique is shown in Fig. 8.

Residual voltage at the machine terminals is supplied by the wye-grounded broken-delta transformer. The 180 Hz

(third-harmonic) component is used by an overvoltage (59T) detector. At the neutral end, the relaying signal is taken across the neutral resistor. The 60 Hz (fundamental) component is used by an overvoltage (59G) level detector. Digital relays allow the residual voltage at the terminals to be calculated internally without the need for auxiliary VTs.

For a ground fault near the neutral, the level of third-harmonic voltage at the generator terminals becomes elevated, and the third-harmonic overvoltage relay operates. This relay must be set in such a way that it does not respond to the maximum third-harmonic voltage present during normal machine operation. Also, the settings of the overvoltage relays at the neutral end and at the generator terminals should be such that detection of faults in the entire stator windings is ensured.

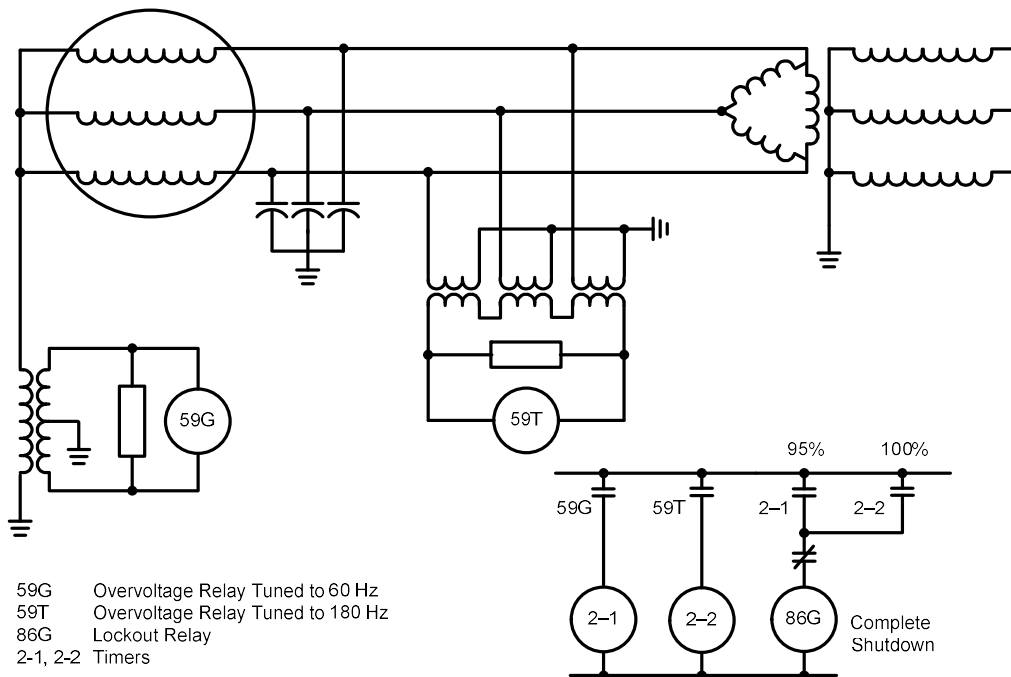

Fig. 8. Third-Harmonic Residual Terminal Voltage-Based Ground Fault Protection Scheme [1]

3) *Third-Harmonic Comparator Technique*

This technique compares the magnitude of the third-harmonic voltage at the generator neutral to that at the generator terminals. The scheme is based on the premise that the ratio of the third-harmonic voltage at the generator terminals to that at the generator neutral is almost constant during the normal operation of the generator. This ratio is upset for ground faults near the neutral or terminal end of the stator windings. Fig. 9 shows a simplified diagram of the comparator scheme.

The basic operating principle of this scheme is the differential principle employing the 180 Hz (third-harmonic) voltages obtained at the neutral and terminal ends of the stator winding. Any difference voltage will cause operation of the differential element. This scheme assumes that the ratio of the third-harmonic voltage at generator terminals to third-harmonic voltage at generator neutral terminals remains approximately constant during normal conditions. If the ratio of the third-harmonic terminal to third-harmonic neutral voltage changes, a difference voltage appears, and the differential relay operates unless a less sensitive setting was employed to accommodate the ratio changes. Also, slight variations in this ratio during normal operation may require reducing the relay sensitivity.

The settings of the conventional 95 percent protective relay (59G) and those of the third-harmonic differential relay (59D) should be chosen in such a way that fault detection coverage for the entire stator winding is ensured. The third-harmonic differential relay detects ground faults near the neutral as well

as at the terminals. The conventional 95 percent ground fault relay detects faults in the upper portion of the windings and overlaps much of the windings protected by the third-harmonic differential relay. The third-harmonic differential relay sensitivity is minimal for a fault near the middle of the winding. At this point, the difference between the third-harmonic voltages at neutral and at terminals is nearly equal to the relay setting. The relay setting should be determined from field tests during commissioning. As an example, Table I shows the magnitude of the third-harmonic voltage at the neutral and at the terminals and their ratio for different operating conditions for a typical generator. The need for multiple VTs and the necessity of field tests for determination of relay settings are the weak points of this scheme. However, this scheme provides the optimum 100 percent fault coverage.

TABLE I
MAGNITUDES OF THIRD-HARMONIC VOLTAGE FOR A
TYPICAL GENERATOR [1]

Unit Load		180 Hz RMS Voltage		Voltage Ratio
MW	MVAR	Neutral	Terminal	Terminal/Neutral
0	0	2.8	2.7	1.08
7	0	2.5	3.7	1.48
35	5	2.7	3.8	1.41
105	5	4.2	5.0	1.19
175	25	5.5	6.2	1.13
340	25	8.0	8.0	1.00

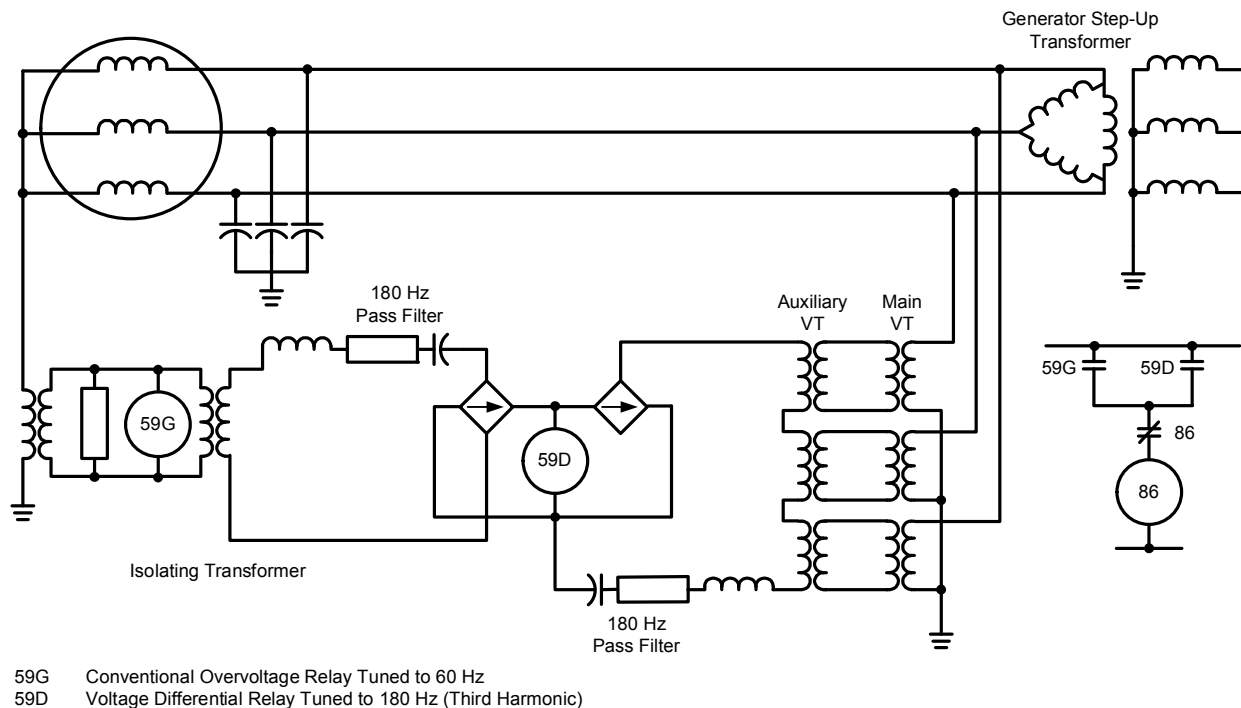

Fig. 9. Third-Harmonic Comparator Based on Ground Fault Protection Scheme [1]

B. Two Types of Subharmonic Injection Schemes

Due to design variations, certain generating units may not produce sufficient third-harmonic voltages to apply the ground fault protection schemes based on third-harmonic signals. Alternate fault detection techniques are needed in these situations. Voltage injection schemes detect ground faults by injecting voltage at the neutral or residually in a broken-delta VT secondary at the terminals. Complete ground fault protection is available when the generator is at a standstill, on turning gear or during startup provided that the injected voltage source does not obtain power from the generator VTs. The subharmonic sinusoidal voltage injection scheme continuously injects a 20 Hz signal through a signal generator

in the generator neutral (Fig. 10). The resultant 20 Hz current is measured. When a ground fault occurs, the 20 Hz current increases and causes the relay to operate. The subharmonic coded voltage injection scheme injects a coded signal (+/- cosine waves) at a subharmonic frequency (Fig. 11), which can be synchronized with the system frequency. One such scheme injects a frequency of 15 Hz (a quarter of the fundamental frequency in 60 Hz systems) in the generator neutral (Fig. 11). The resultant 15 Hz current is measured. When a ground fault occurs, the 15 Hz injection reference signals (Y) and measurement values (X) will be offset, causing the relay to operate. The 15 Hz injection signal is synchronized to the 60 Hz generator terminal voltage.

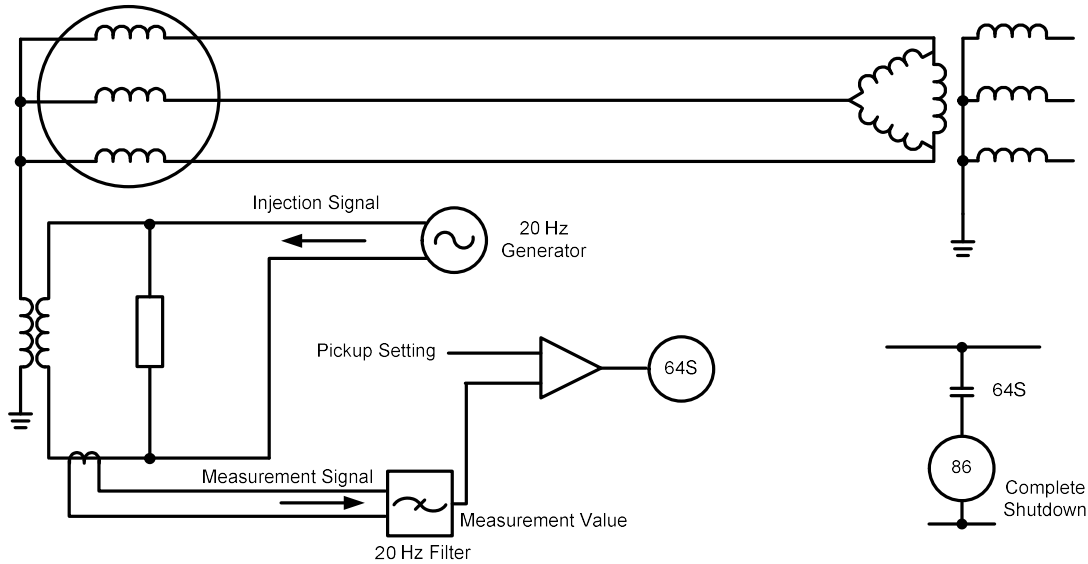

Fig. 10. Subharmonic Sinusoidal Voltage Injection Scheme [1]

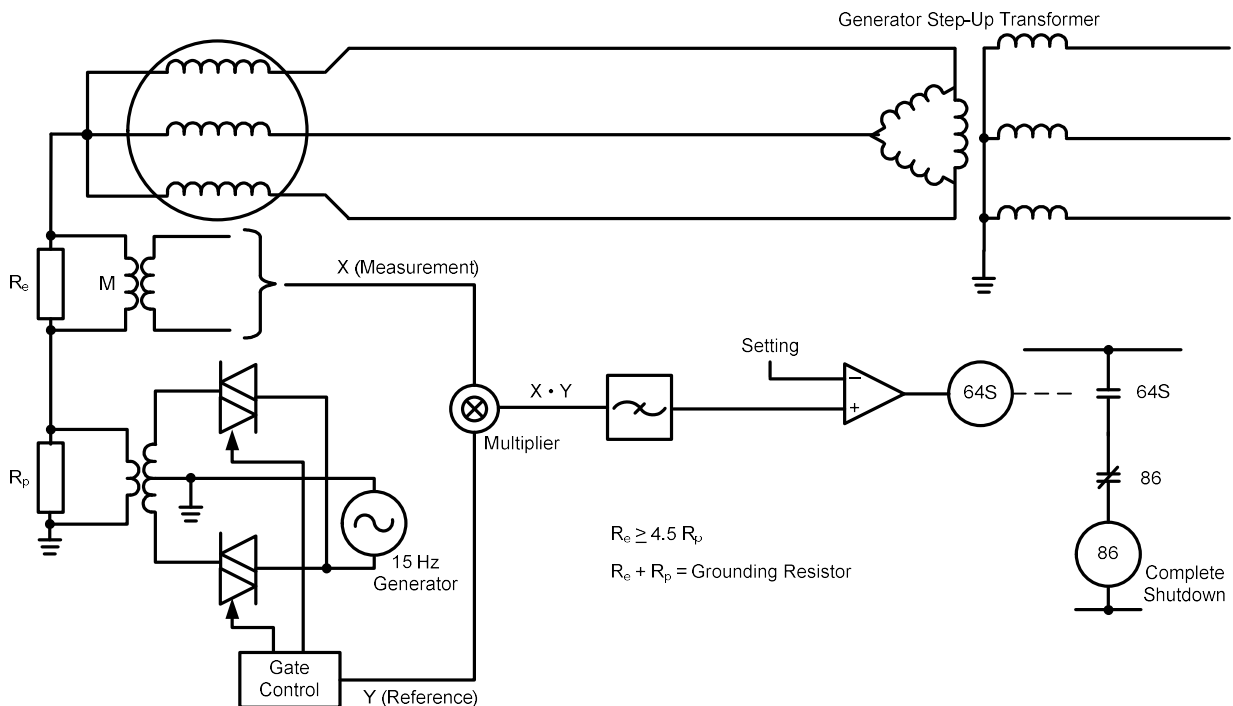

Fig. 11. Subharmonic Coded Voltage Injection Scheme [1]

The voltage injection schemes operate with the same sensitivity for faults over the entire range of the windings. They provide 100 percent ground fault protection independent of the 95 percent ground fault schemes. In addition, these schemes are self-monitoring and have sensitivity independent of system voltage, load current, and frequency. The use of subharmonic frequencies offers improved sensitivity because of the higher impedance path of the generator capacitances at these frequencies. Also, the integrations over a half cycle of the subharmonic frequency result in zero contributions from the signals of system frequency and harmonics (i.e., 60 Hz, 120 Hz, 180 Hz, etc.) and therefore do not influence the measurements. The high cost associated with providing and maintaining a reliable subharmonic source is a disadvantage. Subharmonic voltage injection schemes can detect open circuits in the grounding transformer primary or secondary as this causes a decrease in the 20 Hz current and not an increase as needed by this scheme to indicate a fault. An undercurrent condition is used to give an alarm for indicating a grounding system problem or loss of subharmonic source.

VI. HYBRID GENERATOR GROUND FAULT PROTECTION METHODS

This scheme is a combination of low-resistance grounding (normal operation, $3I_0 = 200\sim 400$ A) and high-resistance grounding ($3I_0 = 3\sim 25$ A), as shown in Fig. 12. The hybrid grounding may be applied in industrial applications with generators directly connected to a bus that services local loads. This application requires careful rating of the components.

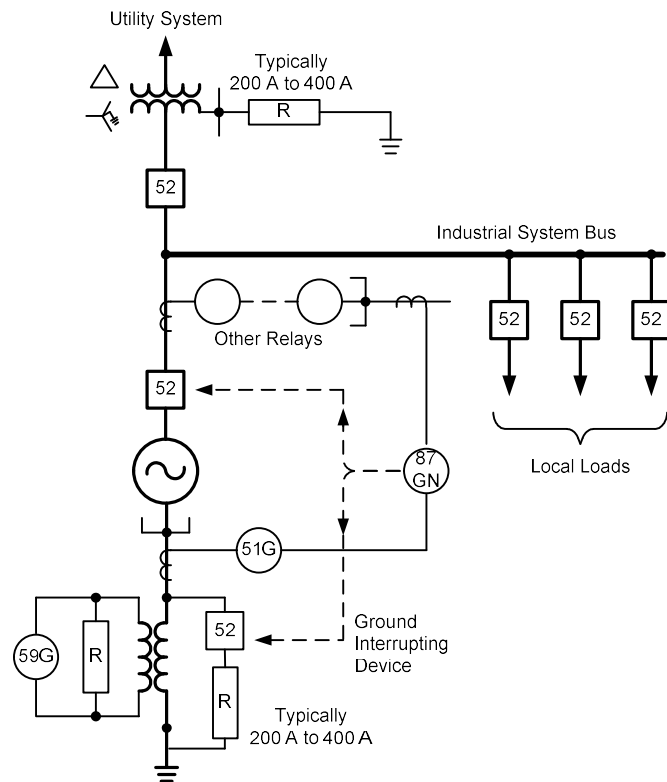

Fig. 12. Hybrid Grounding Scheme [1]

The generator normally operates with the low-impedance ground in parallel with the high-impedance ground. The machine has both high-impedance and low-impedance grounds and provides a source of ground current for ground relay operation on the feeders supplied from the bus (predominantly by low-impedance ground source). If an internal ground fault within the machine occurs, the ground differential relay (87GN) and/or instantaneous overcurrent relay (51G) operates and issues a command to open the ground interrupting device in series with the low-impedance grounding path of the GSU transformer connection and vacuum ground interrupting device in the neutral circuit. Once the low-impedance grounding paths are opened, only the high-impedance grounding path is left, limiting the ground fault current to low levels (5~25 A) to mitigate damage in the stator winding.

VII. TRIPPING MODE

All stator ground detection methods in this section should be connected to trip and shutdown the generator.

In high-impedance grounded hydro machines, it may be acceptable to delay lockout tripping for stator ground faults until the machine is unloaded (until the governor control brings down the turbine speed to the no-load spinning state). Also, another consideration is that the delayed tripping avoids subjecting a machine or its bearing to high speed from sudden load rejection.

VIII. APPENDIX

The appendix presents an example of how to calculate the zero-sequence fault quantities and how to determine the value and ratings of the grounding elements (resistor and transformer) used in the conventional 95 percent, 60 Hz tuned overvoltage relay with a high-impedance grounded protection scheme. A 975 MVA, 22 kV generator is unit-connected to a 345 kV transmission system and grounded through a distribution transformer, as shown in Fig. 13.

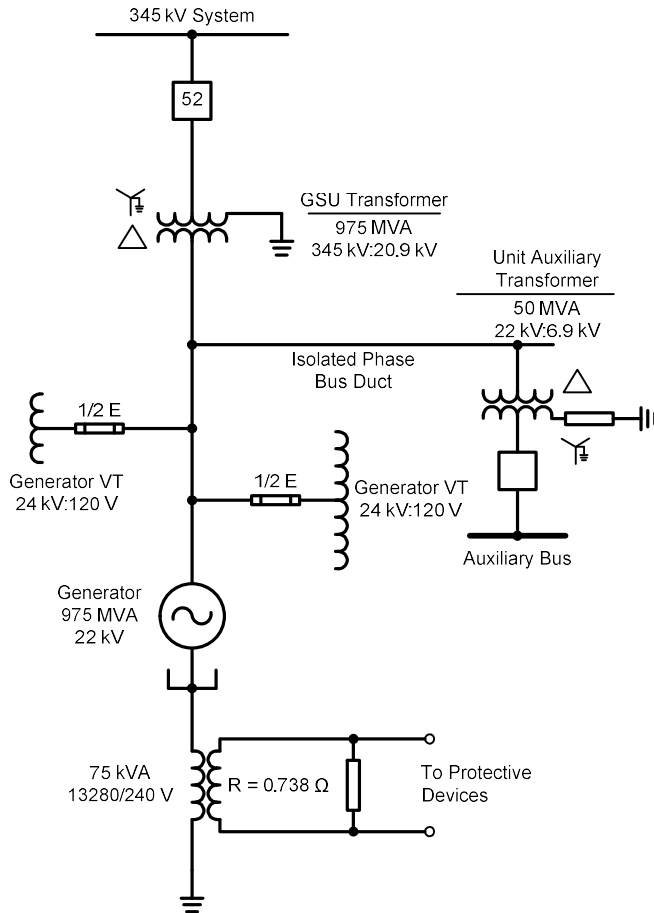

Fig. 13. An Example System [1]

A. Distributed Capacitances for Grounding Resistor and Distribution Transformer

Due to high-resistance grounding, the capacitances to ground in the system are not usually taken into account for short-circuit calculations because of their high-reactance values relative to the series inductive reactances in the system. In general, these are distributed capacitances associated with generator stator windings, the generator surge capacitors and arresters, and the GSU transformer low-voltage windings.

For the determination of the grounding resistor and distribution transformer ratings, these capacitances can be combined and modeled as a single capacitor, as shown in Fig. 14. These capacitances typically account for more than 95 percent of the system capacitance to ground. Other sources are the isolated phase bus ducts, the unit auxiliary transformer high-voltage windings, and the high-voltage windings of any instrument transformers (i.e., generator VTs).

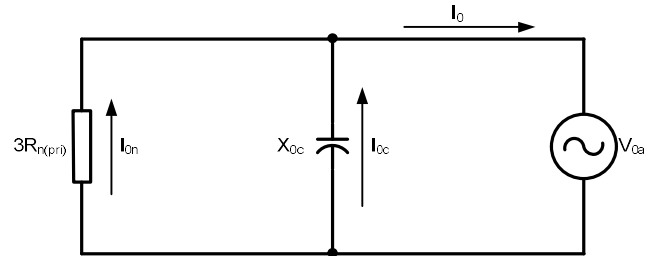

Fig. 14. Reduced Approximate Symmetrical Component Equivalent Circuit

Generally, the capacitance values must be obtained from the equipment manufacturer; however, insulation or power factor tests are excellent sources as well. All capacitance values used for these calculations should be phase-to-ground on a per-phase basis. Note that capacitance in farads or microfarads will need to be converted to capacitive reactance (ohms) at 60 Hz.

Assume the phase-to-ground capacitive reactance of the generator, transformers, leads, and associated equipment in the system shown in Fig. 13 is $X_{0c} = 6780 \Omega$ per phase. The ohmic value of the secondary resistor has been selected so that when reflected across the distribution transformer, the resulting resistance, R_n , is equal to $1/3$ of X_{0c} :

$$R_{n(pri)} = 6780 \Omega \left(\frac{1}{3}\right) = 2260 \Omega \quad (1)$$

$$\begin{aligned} R_{n(sec)} &= \left(\frac{V_s}{V_p}\right)^2 R_{n(pri)} \\ &= \left(\frac{240}{13280}\right)^2 (2260 \Omega) \\ &= 0.738 \Omega \end{aligned} \quad (2)$$

For the purpose of discussion, an SLG fault will be assumed at the terminals of the generator. In terms of the resulting fault quantities (voltage and current), this location yields the worst case. That is, the neutral shift (or development of $3V_0$ across the distribution transformer secondary winding) and fault current magnitudes are greatest. In terms of relay sensitivity, this is the best location for an SLG fault to occur precisely because the quantities are greatest; therefore, the probability of detection is highest. As the fault location is moved deeper into the generator winding toward the neutral, the fault current magnitude decreases, reducing the ability of the protective devices to detect it.

B. Zero-Sequence Current ($3I_0$) Calculation by Symmetrical Components Method

With symmetrical components, SLG faults are calculated by connecting the positive-, negative-, and zero-sequence networks in series, as shown in Fig. 15, and solving for I_0 .

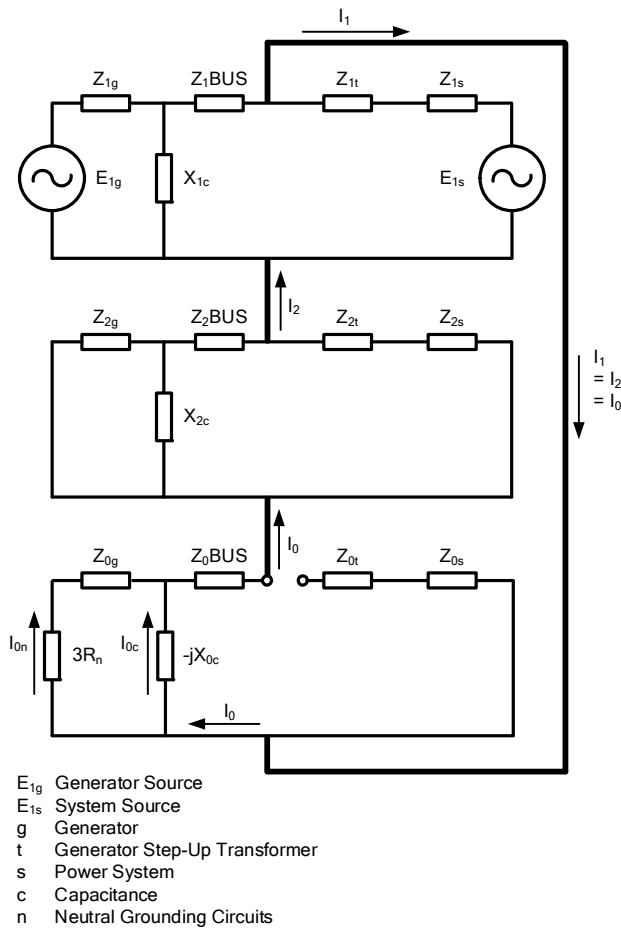

Fig. 15. Symmetrical Component Equivalent Circuit for Calculations of an SLG Fault [1]

The equivalent positive- and negative-sequence impedances of the system and the zero-sequence impedance of the generator can be neglected because they are extremely small compared to the equivalent circuit made up of the neutral resistor and the distributed zero-sequence capacitance. The zero-sequence network is open at the delta winding of the GSU transformer and consists of the reflected generator neutral resistor in parallel with the phase-to-ground capacitance of the generator windings and associated equipment (the generator surge capacitors and arresters and the GSU transformer low-voltage windings). The approximate equivalent circuit is shown in Fig. 14, to which the following definitions apply:

$$I_0 = I_{0n} + I_{0c} \quad (3)$$

where:

I_0 = Total zero-sequence fault current

I_{0n} = Zero-sequence current flowing in the neutral resistor

I_{0c} = Zero-sequence current flowing in the lumped capacitance

Let Z_{0eq} be the equivalent parallel combination of $3R_n$ and $-jX_{0c}$:

$$Z_{0eq} = 0.5(6780 - j6780) = 3390 - j3390 \Omega \quad (4)$$

The zero-sequence voltage is approximately equal to the generator phase-to-ground voltage:

$$V_0 = 22000/\sqrt{3} \text{ V} = 12700 \text{ V} \quad (5)$$

Then, I_{0n} can be calculated as follows:

$$I_{0n} = \left(\frac{V_0}{3R_{n(pri)}} \right) = \frac{12700}{3(2260)} = 1.87 \text{ A} \quad (6)$$

Total zero-sequence current is $I_0 = 1.87 + j1.87 \text{ A}$, because $3R_{n(pri)}$ is equal to X_{0c} , because:

$$\begin{aligned} I_{\text{fault}} &= 3I_0 \\ I_{\text{fault}} &= 3(1.873 + j1.873) \text{ A} \\ &= 5.62 + j5.62 \text{ A} \\ &= 7.95 \angle 45^\circ \text{ A} \end{aligned} \quad (7)$$

$3I_{0n}$ is the current flowing in the generator neutral for an SLG fault at the generator terminals. The current I_{sec} flowing in the distribution transformer secondary wiring and through the grounding resistor can be obtained as follows:

$$\begin{aligned} I_{\text{sec}} &= 3I_{0n} (V_{\text{pri}}/V_{\text{sec}}) \\ &= 5.62 \left(\frac{13280}{240} \right) = 311 \text{ A} \end{aligned} \quad (8)$$

The voltage across the secondary resistor is as follows:

$$\begin{aligned} V_R &= I_{\text{sec}} R_{n(\text{sec})} \\ &= 311(0.738) = 229.5 \text{ V} \end{aligned} \quad (9)$$

The quantities V_R and I_{sec} are available for setting relays. Remember that the resistance value of the grounding resistor was selected on the basis of the zero-sequence capacitances in the system. The continuous ratings of the resistor and grounding transformer are chosen assuming a full neutral voltage shift (due to an SLG fault at the generator terminals). As shown previously, V_R in this example is 229.5 V. This implies continuous ratings for both resistor and transformer of at least 71.4 kW:

$$\begin{aligned} \text{kW} &= \frac{I_{\text{sec}} \cdot V_R}{1000} \\ &= \frac{(229.5)(311)}{1000} = 71.4 \text{ kW} \end{aligned} \quad (10)$$

IX. REFERENCES

- [1] *IEEE Guide for Generator Ground Protection*, IEEE Standard C37.101-2006.
- [2] W. A. Elmore, *Protective Relaying Theory and Application*. New York: Marcel Dekker, 2004.
- [3] C. H. Griffin and J. W. Pope, "Generator Ground Fault Protection Using Overcurrent, Overvoltage, and Undervoltage Relays," *IEEE Transactions on Power Apparatus and Systems*, vol. PAS-101, issue 12, pp. 4490-4501, Dec. 1982.
- [4] J. W. Pope, "A Comparison of 100% Stator Ground Fault Protection Schemes for Generator Stator Windings," *IEEE Transactions on Power Apparatus and Systems*, vol. PAS-103, issue 4, pp. 832-840, Apr. 1984.

Field Fault Protection

Sudhir Thakur

Abstract—This part of the tutorial deals with generator field protection mainly from ground faults and includes these topics:

- Hazards of field faults
- Field ground protection
- Tripping considerations
- Field ground relay selection and settings
- Field overcurrent

The field circuit of a generator is an ungrounded dc system. A single ground fault will not generally affect the operation of a generator nor will it produce any immediate damaging effects. However, the probability of the second ground fault occurring is greater after the first ground fault has occurred. When a second ground fault occurs, a portion of the field winding will be short-circuited, thereby producing unbalanced air gap fluxes in the machine. The unbalanced fluxes produce unbalanced magnetic forces that result in machine vibration and damage. A field ground also produces rotor iron heating from the unbalanced currents, which results in unbalanced temperatures that can cause damaging vibration. The tripping practices within the industry for field ground relaying are not well established. Some utilities trip while others prefer to alarm, thereby risking a second ground fault and major damage.

I. HAZARDS OF FIELD FAULTS

The field circuit of a generator is an ungrounded dc system. As such, a single ground fault does not generally affect the operations of a generator nor produce any immediate damaging effects. On a first ground fault, no fault current flows and the need for action is not evident. Thus, this condition by itself is not damaging. The concern with this condition is that a second ground will occur. The second ground will bypass a portion of the field winding and unbalance the air gap flux. The unbalanced flux will produce vibration. The degree of unbalance and the resulting vibration depend on the location and extent of the winding bypassed by the two grounds.

The vibration can be severe enough to cause massive damage. This unbalanced force travels with the rotor and can produce very high vibration that may damage bearing pedestals or even displace the rotor by an amount to cause friction with the stator. If only a small portion of the winding is bypassed, the resulting vibration may be undetected.

Even if the second ground does not bypass the field winding significantly, this ground can still cause damage. The field current is diverted, in part at least, from the intervening turns bypassed by the two grounds. This current in the rotor forging causes local heating that can create rotor distortion and eventually produce damaging vibration.

II. FIELD GROUND PROTECTION

Several protection methods can detect rotor field grounds. The protection method depends on the type of excitation system in use. This section discusses five methods for field ground detection.

A. Using a DC Source

The scheme shown in Fig. 1 employs a dc source in series with an overvoltage relay coil that is connected between the negative side of the generator field winding and ground. This scheme is used on generators with brushes. A ground anywhere in the field causes current through the relay. A brush grounds the rotor shaft because the bearing film may insert enough resistance in the circuit for the relay to not operate on a ground fault. The detection sensitivity of this scheme in terms of ground resistance is highly variable. The relay current depends on fault resistance, fault location, and field voltage, which varies with the load on the generator. One to three seconds of time delay helps prevent unnecessary operations for momentary unbalances of the field circuit with respect to the ground. These momentary unbalances may be caused by fast responses of thyristor-type excitation systems.

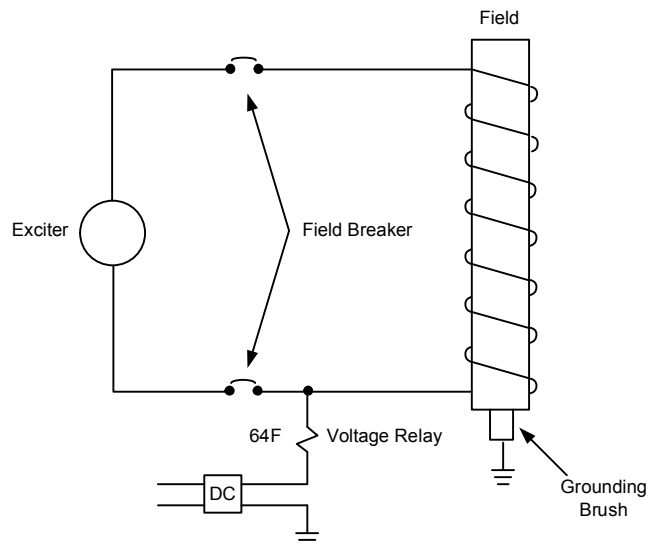

Fig. 1. Field Ground Detection Using a DC Source

B. Nonlinear Voltage Divider Method

Fig. 2 illustrates another method used to detect field circuit grounds on generators with brushes. This method uses a voltage divider and a sensitive voltage relay between the divider midpoint and ground. The voltage divider consists of two standard resistors and one nonlinear resistor. A maximum voltage is impressed on the relay by a ground on either the positive or negative side of the field circuit. However, at the null point between the positive and negative, a ground fault does not produce any voltage across the relay. This is overcome with a nonlinear resistor whose resistance varies with the applied voltage. A manual pushbutton can also be used to shift the null point.

C. Field Ground Detection Using Pilot Brushes

Fig. 3 shows the addition of a pilot brush to gain access to the rotating field parts. Normally, this is not done because eliminating brushes is an advantage of a brushless system. However, detection systems can detect field grounds if a collector ring is provided on the rotating shaft along with a pilot brush that can be dropped periodically to monitor the system. The ground check can be done automatically by a sequencing timer and control or by an operator. A ground fault short circuits the field winding to rotor capacitance, C_R , which unbalances the bridge circuit. If a voltage is read between the ground and the brush, which is connected to one side of the generator field, then a ground exists.

D. Field Ground Detection for Brushless Machines

This section shows a method to detect field grounds for brushless machines.

Fig. 4 illustrates a method for continuous monitoring for field grounds without using pilot brushes. The relay transmitter is mounted on the generator field diode wheel. Its power source is the ac brushless exciter system. Current is determined by the field ground resistance and the location of the fault with respect to the positive and negative bus. The transmitter detects the resistance change between the field winding and rotor core. The transmitter LED (light-emitting diode) emits light for normal conditions. The receiver is mounted on the exciter housing. The receiver infrared detectors sense the light signal from the LED across the air gap. Upon fault detection, the LED turns off. Loss of LED light to the receiver actuates the ground relay and initiates a trip or alarm. To prevent a false trip or alarm, the relay has a settable time delay.

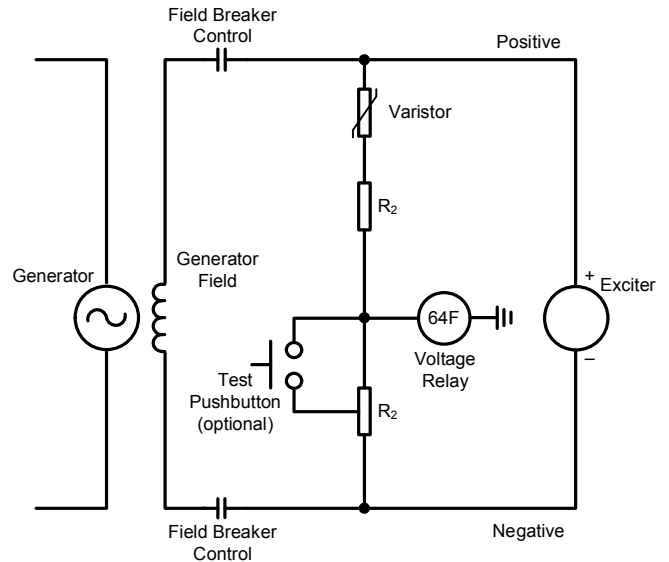

Fig. 2. Field Ground Detection Using a Voltage Divider

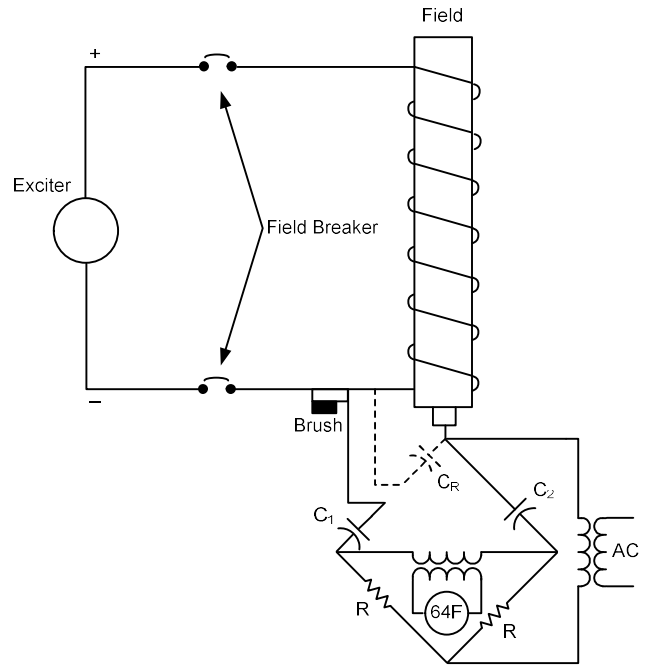

Fig. 3. Field Ground Detection Using Pilot Brushes

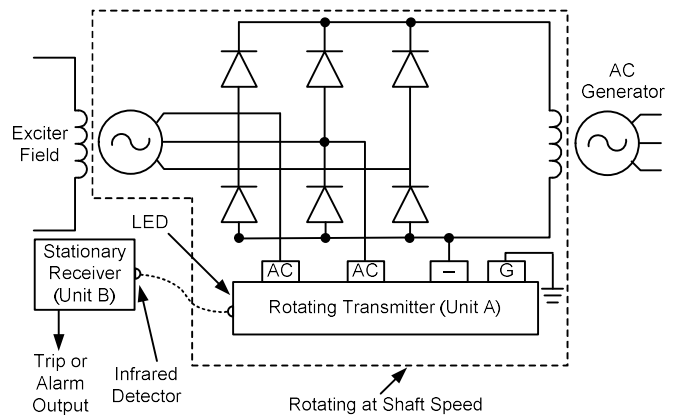

Fig. 4. Field Ground Detection for Brushless Machines

E. Field Ground Detection for Machines With Brushes

Fig. 5 shows a field ground detection scheme using a low-frequency square-wave injection method. A ± 15 -volt square-wave signal is injected into the field through a coupling network. The return signal waveform is modified because of its field winding capacitance. The injection frequency setting is adjusted (0.1 to 1.0 Hz) to compensate for field winding capacitance. From the input and return voltage signals, the relay calculates the field insulation resistance. The relay set points are in ohms, typically with a 20-kilohm alarm and 5-kilohm trip or critical alarm. Reference [1] provides more detail.

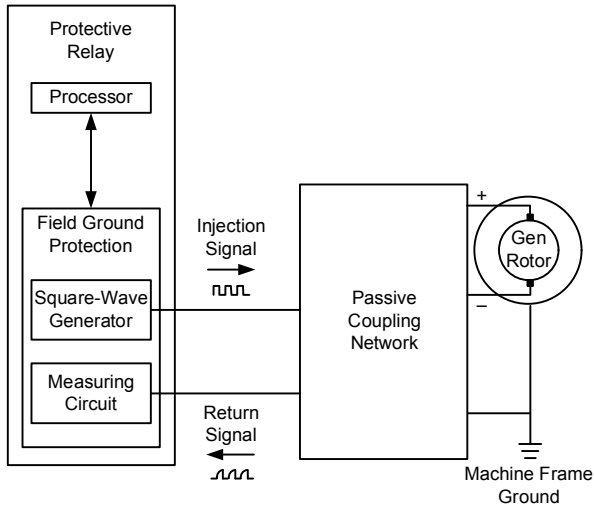

Fig. 5. Field Ground Detection Using an Injection Voltage Signal

III. TRIPPING CONSIDERATIONS

From a protection viewpoint, immediate tripping is recommended when the first ground is detected. However, most installations alarm. Many utilities have instructions to shut down the machine in an orderly manner if the ground alarm persists. If the alarm option is chosen, vibration monitoring equipment should be included in the design to trip the prime mover and field and generator breakers when the vibration level exceeds that seen at the time of synchronization or for a system fault.

IV. FIELD GROUND RELAY SELECTION AND SETTINGS

Field ground relays are selected on the basis of the voltage rating of the field windings. The rating must be higher than the maximum continuous operating voltage. The relays also must withstand the short-time maximum field forcing capability of the excitation system. Relays with time delays can override any transients.

V. FIELD OVERCURRENT

The field circuit continuously operates for a field current required for a generator rating at a rated power factor and rated voltage. The field circuit is rated to continuously provide the field current required for the MVA rating at rated power factor and voltage. This field current is called AFFL (amperes of the field at full load). Field current in excess of the rating is required because of power system disturbances, shorted turns, or excitation system malfunctions. The field winding short-time capabilities as defined by [2] are shown in Fig. 6, which shows that rotor winding temperatures under these conditions will exceed rated load values. Reference [3] assumes a maximum of two such operations per year.

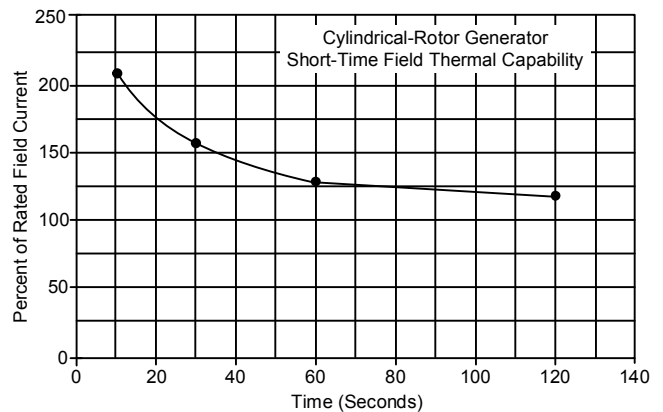

Fig. 6. Generator Field Short-Time Thermal Capability

Overcurrent protection ensures that the thermal capability is not exceeded and that field forcing to the full capability of the winding is also permitted. Field overcurrent protection is provided by means of a direct measurement of field current or field voltage. A dc current relay measures the dc current directly across a shunt. Alternately, a dc voltage can be connected across the field winding. These devices can then trip the prime mover and the field and generator breakers.

VI. REFERENCES

- [1] C. J. Mozina, "Advances in Generator Field Ground Protection Using Digital Technology," proceedings of the Industrial and Commercial Power System Technical Conference, May 2002.
- [2] *IEEE Standard for Cylindrical-Rotor 50 Hz and 60 Hz Synchronous Generators Rated 10 MVA and Above*, IEEE Standard C50.13-2005.
- [3] *IEEE Guide for AC Generator Protection*, IEEE Standard C37.102-2006.

System Backup Protection

Demetrios Tziouvaras, Quintin Verzosa, Jr., and Thomas E. Wiedman

Abstract—System backup protection is commonly applied to protect generators from supplying prolonged fault currents to external faults in the power system when protective equipment fails. It consists of time-delayed relaying to detect phase and ground faults external to the generator protection zone. This section of the tutorial covers the basic types of system backup protection that are widely used for synchronous generators and discusses the types of protective relays used, their purpose and setting considerations, as well as the consequences of not installing backup protection.

I. INTRODUCTION

System backup protection for generators consists of time-delayed protection for phase-to-ground and multiphase fault conditions. Backup generator protection schemes protect against failure of the system protection relaying and subsequent long clearing system faults. Relay settings for backup relaying must be sensitive enough to detect low fault current conditions. The settings must balance the opposing requirements for sensitivity to detect distant faults and the security to prevent unnecessary generator tripping.

Fig. 1 shows the basic types of backup protection used on unit generator-transformer arrangements, and Fig. 2 shows the basic relay types for synchronous generators connected directly to the power system. Backup protection is generally divided into phase fault backup protection and ground fault backup protection. Phase fault protection is provided by a distance (21) relay or an overcurrent (51V) relay that is either controlled or restrained by voltage. Overcurrent relays (51G) provide ground fault protection. In addition, the negative-sequence (46) relay, described in Chapter 3.4, provides protection for unbalanced phase and ground faults but not for balanced three-phase faults.

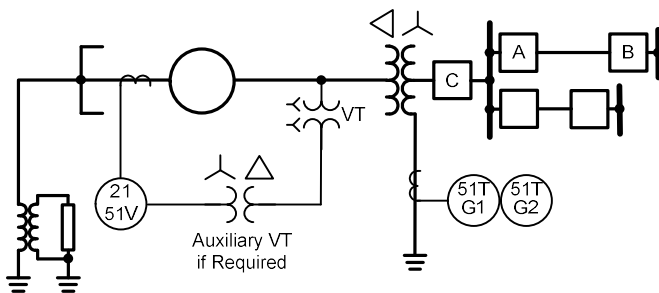

Fig. 1. Application of System Backup Relays for a Unit Generator-Transformer Arrangement

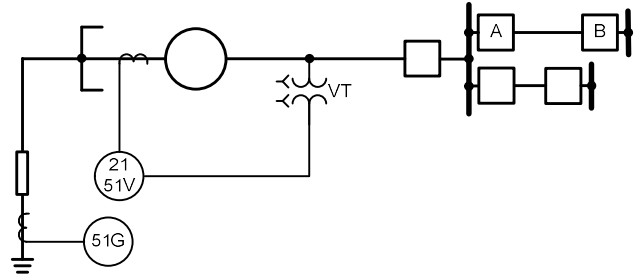

Fig. 2. Application of System Backup Relays for a Generator Connected Directly to a Power System

II. PHASE FAULT PROTECTION

Two types of relays are commonly used for system phase fault backup protection—distance type relays or voltage-controlled (or voltage-restrained) overcurrent relays. System backup protection is time-delayed and coordinated with transmission line protection. The relay type selected for any application is usually a function of the type of relaying used on the lines that are connected to the generator (i.e., overcurrent protection for lines that are protected by overcurrent relays and distance protection for lines that are protected by phase distance relays). Overcurrent backup relays are difficult to coordinate with line distance relays because of the variability in trip time for overcurrent relays for different system conditions.

As shown in Fig. 1 and Fig. 2, CTs (current transformers) for phase fault protection are normally connected to the neutral side of the generator to provide additional backup protection for the generator.

The distance relay may be supervised by an instantaneous overcurrent relay to prevent false operation for a loss-of-potential condition. The voltage-restrained overcurrent relay may be supervised by a voltage balance relay to prevent false tripping for loss of voltage. A voltage balance relay that compares the voltage output of two sets of VTs (voltage transformers) connected at the generator terminals provides the desired supervision. Digital relays may have a loss-of-potential detection function that blocks distance element operation. See Chapter 3.7 for a detailed discussion of VT signal loss considerations.

When the backup phase fault protection is connected to the CTs on the neutral terminals of the generator, it also provides backup protection for the zone between the generator and the synchronizing breaker before the generator is synchronized to the system. The generator fault currents can decay quickly during low-voltage conditions created by a close-in fault [1]. In these applications, the fault current decrement curve for the

generator/exciter should be reviewed carefully for time constants and currents. See Chapter 1 for more details.

A. Overcurrent Phase Backup Protection

The simplest type of overcurrent phase backup protection is the overcurrent relay. This relay must be set above load and have a long enough time delay to ride through generator swings and coordinate with other system backup protection. At the same time, it must be set low enough to trip for remote phase faults for various system conditions. The settings must be reviewed to ensure that the relay will not operate during system emergency conditions where generator terminal voltage is depressed and stator load currents may be higher than the normal generator rating. In most cases, reliable settings criteria cannot be met on a realistic system. A utility survey of generator backup protection practices found minimal applications of overcurrent backup protection [2].

The pickup setting of an overcurrent relay would normally be 1.5 to 2.0 times the maximum rated current for the generator to prevent false trips during some emergency overload conditions. Because the generator fault current decays to near-rated full load current as determined by synchronous reactance and the generator time constant, the relay setting will be too high to pick up for long duration faults. Only in a small number of applications will the system coordination requirements and the generator time constants allow a reliable setting for a simple overcurrent backup. For the previously cited reasons, the use of simple overcurrent generator backup protection is not recommended.

Therefore, when phase overcurrent backup relays are applied, they are either voltage-controlled or voltage-restrained. Voltage supervision allows both types of relays to remain in a picked-up state and time out as the current decays with time because of the current decrement characteristic of the generator. The voltage supervision prevents them from operating under emergency overload conditions.

The voltage-controlled overcurrent relay consists of a sensitive low pickup time-overcurrent element that is supervised or torque-controlled by a voltage element. The voltage element is picked up and disables the overcurrent element from tripping during normal and emergency overload conditions. Under fault conditions where the voltage drops below a set level, the voltage element will drop out, permitting the overcurrent element to operate.

The voltage-restrained overcurrent relay, on the other hand, consists of an overcurrent element whose pickup level varies as a function of the voltage applied to the relay. Fig. 3(a) shows a typical characteristic of a modern voltage-restrained overcurrent relay. During nonfaulted conditions, the generator terminal voltage is above the voltage setting, V_{s1} , and the current pickup setting is I_s . When a close-in fault occurs, the voltage can drop below the voltage setting, V_{s2} , and the current pickup level is reduced by the factor k to kI_s . For voltages between V_{s1} and V_{s2} , the pickup level varies proportionately between I_s and kI_s . Fig. 3(b) shows a characteristic of an electromechanical voltage-restrained overcurrent relay.

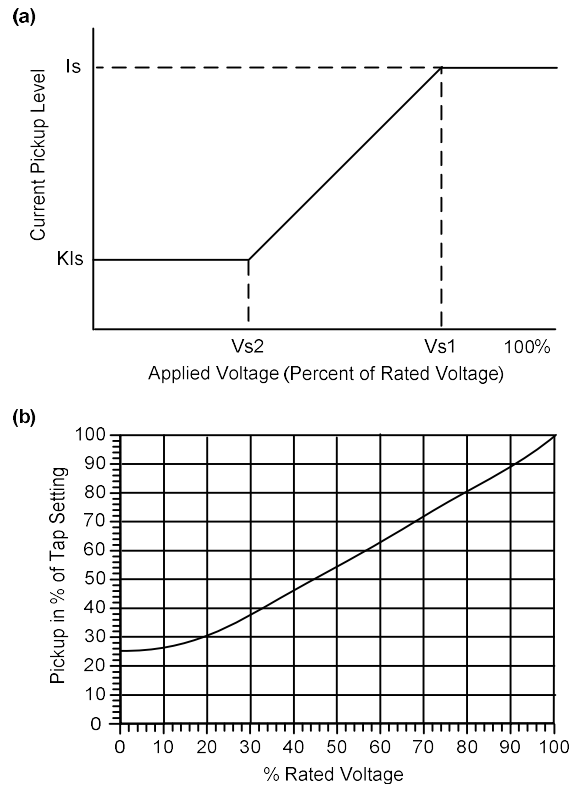

Fig. 3. Voltage-Restrained Overcurrent Relay Characteristic

If set properly, the overcurrent pickup levels in both types of relays will be below the generator fault current level as determined by the synchronous reactance.

The 51V voltage element setting should be calculated such that under extreme emergency conditions (with lowest expected system voltage), the 51V relay will not misoperate.

The generator current for a three-phase fault is lowest for an unloaded generator with the regulator out of service. This is the worst case condition used for setting the minimum overcurrent element pickup for these two types of relays. For a voltage-controlled relay, the overcurrent element pickup setting should be 30 to 40 percent of full load current. Because the tripping times of the backup overcurrent relays are delayed about 0.5 second or more, the generator currents are calculated using the unsaturated synchronous reactance of the generator. With the regulator out of service and only minimal auxiliary load, a typical value for the voltage behind the synchronous reactance is approximately 1.2 pu. Given a typical synchronous impedance of 1.5 pu and a step-up transformer impedance of 0.1 pu, the maximum steady-state current will be 0.75 pu without field forcing. Field forcing is an exciter function that boosts field current beyond its normal output for a short period during fault conditions.

These settings do not normally allow the backup relaying to protect for faults on the auxiliary bus because of the large impedance of the station service transformer. Some system faults result in voltage drops at the generator terminals but with fault current that is below 0.75 pu pickup level. A voltage-controlled overcurrent relay is preferred in this case

because the pickup level can usually be set lower than the voltage-restrained relay.

Time-delay settings must be coordinated with transmission system primary and backup protection, including breaker failure time, to allow for selectivity. Coordination is usually calculated with zero voltage restraint. This is a conservative approach because, in reality, some voltage restraint is present and will improve the coordination.

Some generator exciter systems use only the VT connected to the generator terminals as input to the field excitation. In this case, the generator fault current may decay rapidly when there is low voltage at the generator terminals because of a fault. Consequently, the overcurrent phase fault backup may not operate for system faults. Therefore, the performance of these relays should be checked with the fault current decrement curve for a particular generator and VT static connected excitation system.

To provide complete multiphase backup system protection, three voltage-controlled or voltage-restrained time-overcurrent relays are used. In some smaller and medium size generator applications, a single overcurrent (51V) relay is used if a negative-sequence overcurrent (46) relay is included. The two relays together provide backup protection for all types of external multiphase faults. If the generator is connected through a delta-wye step-up transformer, as shown in Fig. 1, certain voltage-restrained relays require auxiliary transformers that shift the relay voltage phase angle to match the system voltages in order that system faults are detected correctly. See the following discussion that applies to distance phase backup protection.

B. Distance Phase Backup Protection

The second type of backup phase protection is the distance relay. A utility survey of generator backup protection practices shows that the distance relay is by far the most common type of phase system backup protection [2]. Typically one or two zones of distance relaying with a mho characteristic is applied. If the generator is connected to the system using some means other than a delta-wye step-up transformer (e.g., direct connection or wye-wye transformer) where there is no phase shift, the standard CT and VT connections for a mho distance relay will provide accurate impedance measurements for system faults (neglecting infeed).

If the generator is connected through a delta-wye step-up transformer, certain relays require auxiliary transformers that shift the relay voltage phase angle to match the system voltages in order that system faults are detected correctly, as shown in Fig. 1. The turns ratio of the auxiliary VT is chosen so that the line-to-line voltages on either side of the auxiliary VTs have a ratio of 1:1. Relays that measure impedance based on the compensator distance element principle and some

models of digital distance relays that have a setting to provide the phase shift within the relay do not require an auxiliary VT.

When the distance relay is connected as shown in Fig. 1 or Fig. 2, the relay not only provides backup protection for system faults but also provides some backup protection for phase faults in the generator and generator zone before and after the generator is synchronized to the system. In some cases, the distance relay is connected looking toward the system, receiving both current and voltage from CTs and VTs connected to the terminals of the generator. In addition to its normal system backup protection function, the offset mho characteristic is used to provide some backup phase fault protection in the generator and generator zone when the generator is connected to the system. However, this connection will not provide backup generator protection when the generator is disconnected from the system, because there will be no fault current through the CTs.

The distance relay application requires a setting that detects a line fault in the event of protection equipment failure. The relay impedance reach and time delay must be coordinated with system primary and backup protection, including breaker failure time, to allow selectivity. In addition, the setting must remain conservatively above the machine rating to prevent inadvertent trips on generator swings and severe voltage disturbances.

In many cases, a number of generators and lines are connected to the generating station, as shown in Fig. 4. The impedance relay for each generator requires sensitive settings to detect faults at the ends of long lines in the presence of other sources. Sensitive settings may cause the backup relays to unnecessarily trip a generator under some loading conditions or for minor, stable swings. With this type of system configuration, it is generally possible to set these backup relays to detect only close-in faults. Redundant line relaying and breaker failure relaying are necessary for line, bus, and transformer protection.

These system configurations generally require settings criteria that include compromises in the desired protection to maintain generator security. See [3] and [4] for guidance in setting the backup (21) relays.

Set the impedance relay to the smallest of the three following criteria:

- 120 percent of longest line (with infeed). If the unit is connected to a breaker-and-a-half bus, this percent is calculated using the length of the adjacent line.
- 50 to 66.7 percent of load impedance (200 to 150 percent of the generator capability curve) at the machine-rated power factor.
- 80 to 90 percent of load impedance (125 to 111 percent of the generator capability curve) at the relay maximum torque angle (MTA).

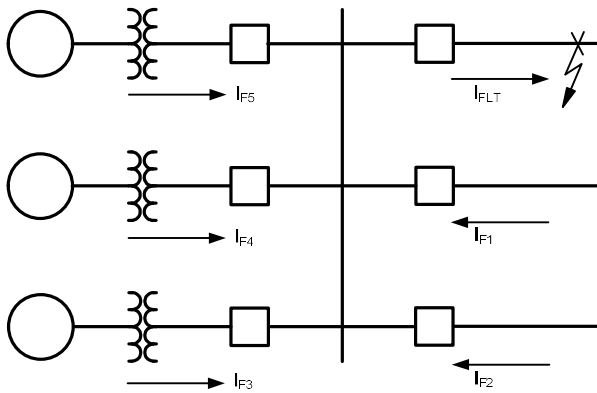

Fig. 4. Complex System Configuration With Infeeds

When equipped with modern excitation control and protection systems, generators can operate within short time capabilities to provide system var support during recoverable power swings. A setting value above 200 percent of the capability curve may be required. This may limit the reach even further or may require a much longer time delay.

Because of recent blackouts caused by voltage collapse, the distance setting should be checked for proper operating margins when the generator is subjected to the lowest expected system voltage. The North American Electric Reliability Corporation (NERC) has established a system voltage level of 0.85 pu as the lowest voltage at which protection must operate properly.

These criteria normally require compromises in the desired protection to maintain generator security. It is recommended that these relay settings be evaluated between the generator protection and the system protection engineers to optimize coordination while still protecting the turbine generator. Stability studies may be needed to determine a secure set point and time delay to optimize protection and coordination.

Digital multifunction generator protection relays make it possible to use two zones of distance protection. In this case, Zone 2 is set as previously described. When two zones are applied for phase fault backup protection, Zone 1 with time delay can be set to provide backup protection for faults in the local switchyard. The Zone 1 timer is set to the normal Zone 2 time-delay criterion to coordinate with high-speed line protection plus the breaker failure time. The reach is typically set to see the generating station high-voltage bus (120 percent of the GSU [generator step-up] transformer impedance). This setting should be checked for coordination with the Zone 1 element of the shortest line emanating from the bus. If the Zone 1 setting, based on 120 percent of the GSU transformer impedance, overreaches the shortest line Zone 1 reach, the system backup Zone 1 reach will need to be reduced to about 80 percent of the shortest line Zone 1 setting (infeed neglected).

Alternatively, Zone 1 is used to provide high-speed protection for phase faults in the generator isolated-phase bus. For this application, the Zone 1 element is set to 50 percent of the GSU transformer impedance with no intentional time delay. The Zone 1 element provides redundant high-speed

phase fault protection for the generator terminal and the isolated-phase bus (which is otherwise protected only by the overall generator-transformer differential relay) while the Zone 2 element provides system backup protection for phase faults. Note that this high-speed element can operate on an out-of-step or severe power swing condition, which is undesirable, and in addition provide misleading target information.

When performing calculations that involve impedances with different voltage bases, the impedances should first be converted or referred to a common voltage base, usually the generator voltage. Alternatively, calculation errors are more easily avoided by working in the per-unit system. The calculated per-unit reach can then be converted to secondary ohms to set the relay.

Fig. 5 shows an application of a two-zone distance relay where Zone 1 is set to cover 120 percent of the GSU impedance and Zone 2 is limited by the GCC (generator capability curve) at 67 percent of the GCC at the rated power factor angle (RPFA). Here the Zone 2 reach will not provide adequate phase fault system backup protection as it would require an extremely large setting. The only way to ensure adequate protection to avoid sustained currents to the fault is to provide redundant transmission system protection and breaker failure protection.

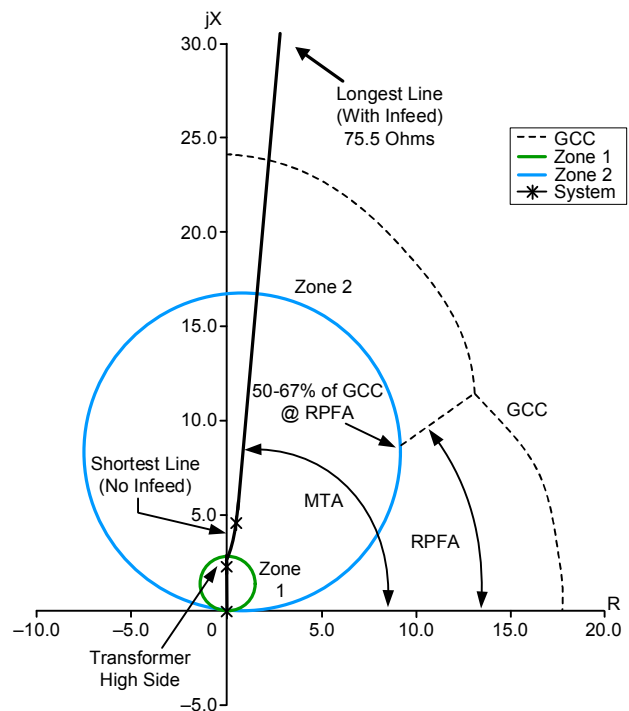

Fig. 5. Distance Relay Setting Example Plotted on an R-X Diagram [4]

Other beneficial features of modern digital protection that can help improve the security of the distance backup protection include power swing blocking, load encroachment, and shaped characteristics. The power swing blocking function is used to block selected zones and allow them to have a longer reach and still prevent inadvertent tripping during severe but recoverable power swings. The two other

features are used to restrict the distance relay resistive and reactive reaches independently.

III. BACKUP GROUND PROTECTION

When a generator is connected in a unit generator-transformer arrangement, it is generally desirable to connect an inverse or very inverse overcurrent ground relay (51TG1) and, optionally, a second overcurrent relay (51TG2) to a high-accuracy current transformer in the GSU transformer high-side neutral, as shown in Fig. 1. When the generator is connected directly to the system, a time-overcurrent ground (51G) backup relay is connected to a CT in the generator neutral, as shown in Fig. 2.

Backup ground protection is set to pick up for ground faults at the end of all lines out of the station and is set to coordinate with the slowest ground fault protection on the system. For lines protected by overreaching ground distance relays, the backup relay time-coordinates with the ground distance timer plus the breaker failure relaying time delay. Any high-resistance ground fault outside the reach of the transmission line ground distance relays seen by the backup ground relays could cause undesirable tripping of multiple generator units. Even when ground distance relays are used, an inverse or very inverse time-overcurrent element for transmission line ground fault protection is recommended to cover high-resistance faults and also prevent possible miscoordination.

Backup relays 51TG1 and 51G are generally connected to shutdown the generator. However, if the “unit separation tripping scheme” (see Chapter 5.1) is used, 51TG1 trips only the high-side generator breakers and 51TG2 is required to shut down the generator should the high-side breaker fail to open. 51TG2 is set to coordinate with 51TG1.

If a ground fault occurs between the GSU transformer high-voltage wye-connected winding and the high-side generator breaker, 51TG2 will operate but will be very slow and practically provide no protection if the fault is in the transformer. A restricted ground fault differential relay connected to the transformer neutral CT and the phase CTs covering the generator breaker is recommended to provide sensitive protection and high-speed tripping and shut down the generator.

IV. SYSTEM BACKUP WITH GENERATOR NEGATIVE-SEQUENCE RELAYING

The negative-sequence relay is covered in detail in Chapter 5.4. This section will emphasize the relay characteristics as they apply to system backup protection. The negative-sequence relay is set to protect the generator based on rated current capabilities from IEEE Standards C50.12 and C50.13. It is desirable to set the relay to protect for system series unbalance, which requires the use of a sensitive relay. A low setting allows the negative-sequence relay to protect the generator for open conductor conditions that may not be detected by any other relay protection. Most often, digital and some electronic negative-sequence relays are capable of the

sensitive setting, while electromechanical relays do not provide this sensitivity.

The most recent survey on backup protection showed minimal operations of the negative-sequence overcurrent relays for faults on the power system [2]. This validates the idea that setting the negative-sequence relays at the generator capability down to continuous ratings still leaves a large coordination margin between the tripping times of system fault protection and the generator negative-sequence protection. On the other hand, generator negative-sequence relays may not be good backups for system faults because of additional equipment damage caused by long tripping time before the fault is cleared and subsequent generator instability for the extended fault clearing times. As pointed out before, the negative-sequence relay does not protect for balanced three-phase faults.

V. TRIPPING MODE

A. Phase Faults

The 21 and 51V phase relays provide generator backup protection for phase faults. These relays are connected to energize a hand-reset lockout relay that trips the main generator breaker(s), the generator field and/or exciter breakers, the low-side breakers on the UATs (unit auxiliary transformers), and the prime mover. These functions should not be used together; only one or the other is applicable to a particular system. Refer to Chapter 5.1 for more details about tripping modes.

B. Ground Faults

The backup for the ground fault relay 51TG1 for unit generator-transformer arrangement in Fig. 1 and 51G for direct-connected generator arrangement in Fig. 2 provide backup protection on the transmission lines connected to the station bus. These relays will generally be connected to shut down the generator in the same manner as described for the phase relays 21 and 51V.

In some cases, when the “unit separation scheme” is used, 51TG1 is connected to trip the GSU transformer high-side breaker(s) only and will thus disconnect the generator to leave it isolated on its station service whenever a transmission line ground fault is not cleared by primary protection. If the high-side generator breaker fails to open, 51TG2 will trip the lockout relay to shut down the generator.

VI. CONSEQUENCES OF NO SYSTEM BACKUP AND INCORRECT APPLICATION

As stated at the beginning of this chapter, there are tradeoffs in the application of system backup protection. The most recent survey of the industry on this topic outlined both the risks in security and sensitivity. In this survey, a total of 46 backup protection operations were reported by the respondents. Out of this total, there were 26 correct operations and 19 incorrect operations [2].

The backup ground protection had the fewest misoperations. The phase and negative-sequence operations

were nearly evenly split between correct and incorrect. Of these misoperations, nine were faulty or maladjusted relays, three were wiring errors, three were incorrect settings, three were open potential circuits, and one was personnel error. These misoperations emphasize the need for careful application and implementation of the backup protection. It also underlines the fact that these relay schemes are secure when applied and implemented correctly.

The survey also outlined three events that occurred as a result of not having backup relays. Two resulted in a fire that burned up six cubicles as a result of a failed breaker. The third reported generator damage as a result of one hour of operation with one pole of the high-side breaker open. One other incident reported to the authors indicated that a lack of backup protection resulted in damage of two generator rotors. The rotor damage occurred because of a long time clearing ground fault, resulting from a 230 kV breaker failure operation and lack of negative-sequence electromechanical relay sensitivity.

More recently, investigation of generator trips during the North American disturbance on August 14, 2003, indicated that 290 units, about 52,745 MW, tripped because of thirteen types of generator protection functions. The information is summarized in Table I [5].

TABLE I
2003 BLACKOUT GENERATION PROTECTION TRIPS

Function Type	Number of Units
21	8
24	1
27	35
32	8
40	13
46	5
50/27	7
50 BF	1
51V	20
59	26
78	7
81	59
87T	4
Unknown	96
TOTAL	290

Unfortunately, information is not available that directly addresses which of those generator trips were appropriate for the bulk electric system conditions, and which were nuisance trips. However, some undesired generator trips by these protective functions did contribute to expanding the extent of the blackout.

NERC is examining requirements for ensuring coordination of system backup protection with the transmission system and has created a technical reference document that explores generating plant protection schemes and their settings to provide guidance for coordination with transmission protection, control systems, and system conditions to minimize unnecessary trips of generation during system disturbances [5].

VII. CONCLUSIONS

The application of system backup protection at generating plants involves the careful consideration of tradeoffs between sensitivity and security. The risks in applying backup protection can be minimized by careful consideration of the points discussed in this chapter of the tutorial. These risks are far outweighed by the consequences of not having proper backup protection.

VIII. REFERENCES

- [1] T. Higgins, Jr., H. Holley, and L. Wall, "Generator Representation and Characteristics for Three Phase Faults," proceedings of the 43rd Annual Protective Relaying Conference, Atlanta, GA, May 1989.
- [2] G. D. Rockefeller, A. N. Darlington, W. A. Elmore, R. J. Fernandez, J. R. Gil-Berlinches, R. W. Haas, L. E. Landoll, W. J. Marsh, G. R. Nail, A. C. Pierce, C. L. Wagner, and L. S. Wright, "A Survey of Generator Back-Up Protection Practices: IEEE Committee Report," *IEEE Transactions on Power Delivery*, vol. 5, issue 2, pp. 575–584, Apr. 1990.
- [3] *IEEE Guide for AC Generator Protection*, IEEE C37.102-2006.
- [4] C. J. Mozina, M. Reichard, Z. Bukhala, S. Conrad, T. Crawley, J. Gardell, R. Hamilton, I. Hasenwinkle, D. Herbst, L. Henriksen, G. Johnson, P. Kerrigan, S. Khan, G. Kobet, P. Kumar, S. Patel, B. Nelson, D. Sevcik, M. Thompson, J. Uchiyama, S. Usman, P. Waudby, and M. Yalla, "Coordination of Generator Protection With Generator Excitation Control and Generator Capability," presented at the 2007 PES General Meeting, June 2007.
- [5] NERC System Protection and Control Subcommittee, *Power Plant and Transmission System Protection Coordination – Technical Reference Document*. North American Electric Reliability Council, December 2009. Available: <http://www.nerc.com/filez/spctf.html>.

Generator Breaker Failure

Christopher Ruckman and Brent Oxandale

Abstract—A breaker failure scheme needs to be initiated when the protective relay system operates to trip the generator circuit breaker but the breaker fails to operate. Because of the sensitivities required for generator protection, generator breaker failure backup by remote terminal relaying is not possible. Local breaker failure protection is required. Breaker failure protection for generator breakers is similar to that of other breakers on the transmission system, but some subtle differences are addressed in this section of the tutorial.

I. INTRODUCTION

Breaker failure protection provides for the tripping of backup breakers if a fault or abnormal condition is detected by protective relays and the associated generator breaker does not open after trip initiation. Using Fig. 1 as an example, if a fault or abnormal condition in the Generator 1 protection zone is not cleared by Breaker 1 within a predetermined time, locally tripping Breaker 2, Breaker 3, and Breaker 4 is necessary to remove the fault or abnormal condition.

Similar considerations must be given to multibreaker arrangements such as ring-bus or breaker-and-a-half configurations. Fig. 2 illustrates the operation of a local breaker failure scheme applied to a ring-bus station.

A fault in the Generator 1 protection zone requires tripping of two breakers at Station A. If any breaker fails to clear the fault, breaker failure protection initiates the tripping of an additional local breaker and transfer trips a remote breaker.

Fig. 3 depicts a basic breaker failure protection scheme flow chart.

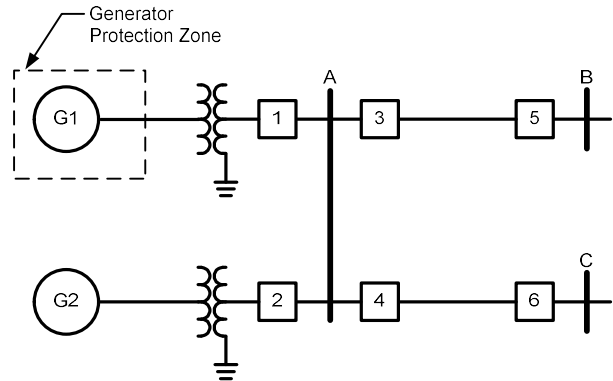

Fig. 1. Directly Connected Generator

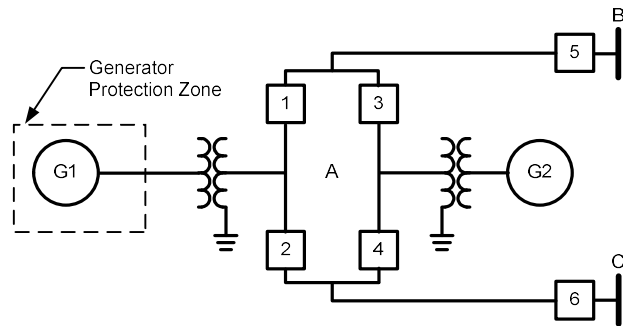

Fig. 2. Ring-Bus Connected Generator

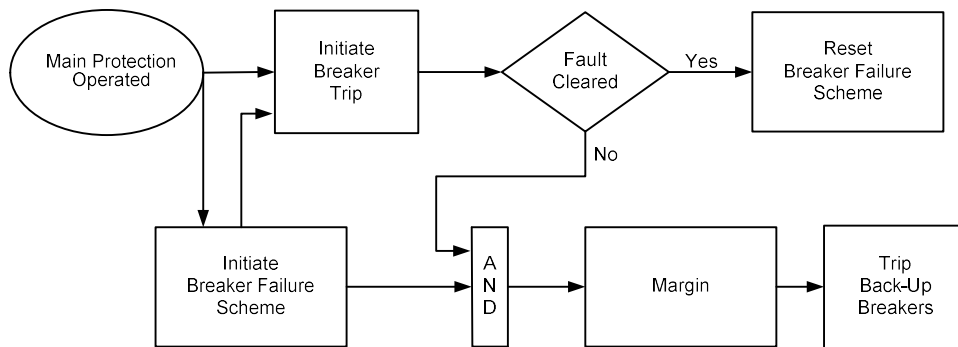

Fig. 3. Breaker Failure Protection Scheme Flow Chart

II. GENERATOR BREAKER FAILURE LOGIC

A functional diagram of a typical generator zone breaker failure scheme is shown in Fig. 4. Like all such schemes, when the protective relays detect an internal fault or an abnormal operating condition, they will attempt to trip the generator breaker and, at the same time, initiate the BF (breaker failure) timer. If the generator breaker does not clear the fault or abnormal condition in a specified time, the timer will trip the necessary breakers to remove the generator from the system. As shown in Fig. 4, the BF timer is initiated by the combination of a protective relay operation and either a current detector (CD) or a breaker closed (52a) status.

The breaker closed (52a) status must be used because faults and abnormal operating conditions, such as stator or bus ground faults, overexcitation (V/Hz), excessive negative-sequence current, excessive underfrequency, reverse power flow, etc., may produce insufficient current for CD operation. If each breaker pole operates independently, each breaker closed (52a) status from all three poles should be paralleled and connected into the logic circuit to provide single-pole breaker failure protection.

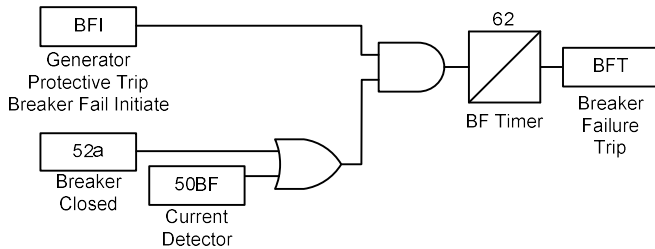

Fig. 4. Functional Diagram of a Generator Breaker Failure Scheme

Fig. 5 shows a variation of this scheme that is applicable to electromechanical current detectors in which the time-out of the BF timer enables the CD to determine if current continues to flow. With this scheme, the pickup time of the CD does not enter into the setting of the BF timer because the CD is not armed until the BF time has expired.

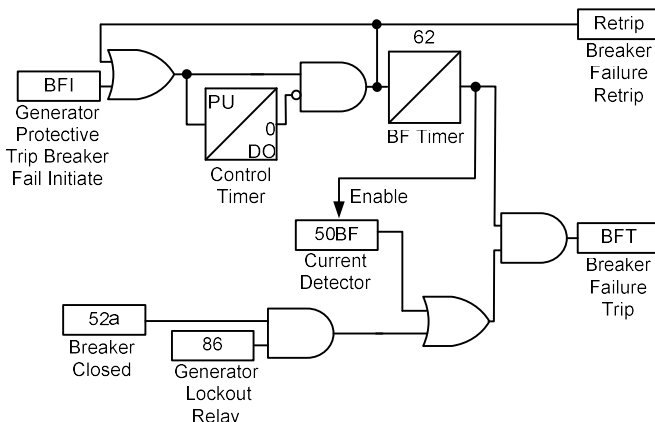

Fig. 5. Functional Diagram of an Alternate Generator Breaker Failure Scheme

While many methods can initiate the breaker failure scheme, it is generally desirable to separate the generator zone protection into groups and have each group operate a separate lockout or auxiliary relay that trips the generator and initiates the breaker failure scheme. With this philosophy, a single lockout or tripping relay failure will not eliminate all protection (See Chapter 5.1). Note that all protective relays in the generator zone should initiate the breaker failure scheme.

Special consideration is necessary when lockout relays are not used in the protective scheme to initiate breaker failure. The protective relay outputs should be sealed in to ensure that breaker failure logic is maintained after the initial fault condition subsides. Fig. 5 includes seal-in logic and a control timer that provide a means to ensure that BF tripping can occur for momentary breaker failure initiate (BFI) signals. For this scheme, the BFI signal is sealed in until the control timer, which is always set longer than the BF timer, times out. This scheme also limits the time window for producing a BF output to a short period following a BFI signal.

Another factor to consider is the operating procedure when a machine is shut down for maintenance. When a ring-bus, breaker-and-a-half, or double-breaker double-bus arrangement is used on the high side of the generator step-up transformer, some utilities isolate the unit generator via a disconnect switch and close the high-voltage breakers to close the ring or tie the two buses together. Under these conditions, isolating the lockout and trip relay contacts prevents unnecessary breaker failure backup operation during generator relay testing. Test switches are sometimes used for this function. When communication is used to activate breaker failure protection in place of hard-wired output contacts, isolating or disabling the signal is necessary to prevent inadvertent breaker tripping and breaker failure initiation during relay testing and communications channel maintenance. Note that if the generator is connected to the system through two circuit breakers, each breaker must be equipped with an independent breaker failure scheme, and both schemes should be isolated to prevent unnecessary tripping during testing.

In the example illustrated in Fig. 5, the 52a breaker failure tripping path is ANDed with the generator lockout relay status. Because this scheme effectively eliminates the generator breaker 52a status from the breaker failure logic before the generator lockout relay trips, it is only applicable when all generator breaker trips actuate the generator lockout relay. The ANDing of the 52A with the 86G is also used for dual-breaker applications where the BFI signal may also be generated by line or bus relays on the adjacent zone. Thus, the less reliable 52a sensing of breaker opening is restricted to generator trips only.

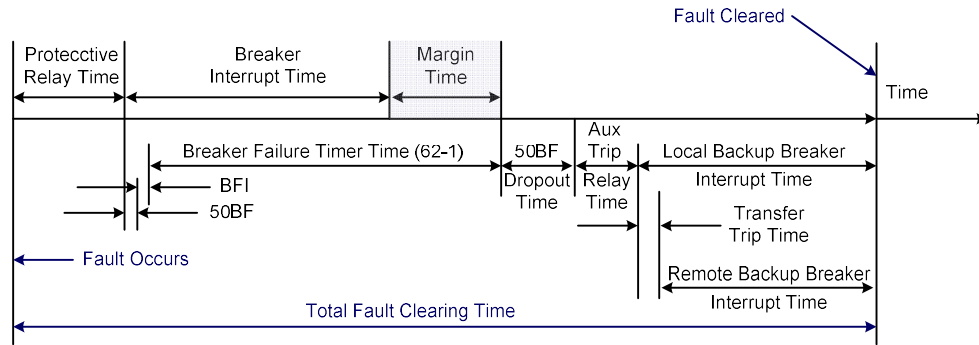

Fig. 6. Breaker Failure Timing Chart

III. BREAKER FAILURE TIMING

One of the most important criteria for determining breaker failure timing is the critical clearing time to maintain system stability, while not allowing a generator or group of generators to go out-of-step from the rest of the system. Breaker failure protection should be fast enough to maintain system stability but not so fast as to compromise tripping security. This is particularly important on bulk transmission lines where stability is critical. In general, the more severe the fault, the faster the fault must be removed from the system to maintain stability. For example, a bolted three-phase fault on the high-voltage bus of a substation adjacent to the generating facility will have a lower critical fault clearing time than a phase-to-phase or phase-to-ground fault. See Chapter 1 and Chapter 3.6 for more discussion on generator stability.

Fig. 6 shows a timing chart for a typical breaker failure scheme. The shaded margin time provides security and should accommodate the following:

- Excessive breaker interrupting time
- Time overtravel (electromechanical relays only)
- CT (current transformer) and VT (voltage transformer) errors
- Safety factor

Of course, this chapter focuses on designing a breaker failure protection system for the generator breaker. The critical clearing time for the generator with which the breaker is associated is not important because the generator is coming offline anyway. But in a multiple-unit power station, the critical clearing time for the adjacent generators is important in determining the time setting.

IV. FAULT DETECTORS

Fault detectors are nondirectional overcurrent devices (or elements in a multifunction relay) with instantaneous pickup and dropout time characteristics. Fault detectors that have a high dropout-to-pickup ratio and whose dropout time is minimally affected by CT saturation and dc offset in the secondary circuit are recommended. Because generators may be served from two breakers, it is important that the CT ratios, excitation characteristics, and fault detector settings be adequate for the maximum fault currents through each

breaker. Both CTs should have the same ratings and adequate capacity to handle the circuit burden.

V. CT LOCATION

Careful consideration should be made when selecting the location of the CTs used as an input to the current detectors in a generator breaker failure scheme. The selected CTs should always measure the current flowing directly into the generator breaker and thus be located locally to the breaker. Generator neutral-side CTs are never appropriate for generator breaker failure because the generator will continue to supply current to an in-zone fault until the stored energy in the field dissipates—even after the generator breaker successfully opens. This will result in an unnecessary backup trip.

VI. OPEN GENERATOR BREAKER FLASHOVER PROTECTION

Another form of breaker failure that may occur and damage the generator is an open breaker flashover (i.e., an internal or external flashover across the contacts of one or more breaker poles to energize the generator). This type of breaker failure protection is described in detail in Chapter 4.1 and is briefly summarized in this section because breaker flashover is a form of generator breaker failure. Breaker flashover is most likely to occur just prior to synchronizing or just after the generator is removed from service, when the voltage across the generator breaker contacts approaches twice its nominal value as the generator slips in frequency with respect to the system. Although circuit breakers are rated to withstand this voltage, the probability of a flashover occurring during this period is increased. Rarely are such flashovers simultaneous three-phase occurrences; thus, most protection schemes are designed to detect the flashover of one or two breaker poles.

If one or two poles of a breaker flash over, the resulting current unbalance will generally cause the generator negative-sequence relay or possibly ground overcurrent backup relays to operate. This initiates tripping of the flashed-over breaker. Because the flashed-over breaker is already open, the generator cannot be isolated by tripping the breaker. In this case, breaker failure relaying is initiated. As shown in Fig. 4, breaker failure relaying is initiated if the CD's are set with appropriate sensitivity.

Modifying the breaker failure scheme, as shown in Fig. 7, decreases breaker flashover detection time. For high-side generator breakers, an instantaneous overcurrent relay (50G) is connected to the neutral of the generator step-up transformer. The relay output is supervised by the generator breaker open (52b) status and provides an additional start to the breaker failure scheme. When the generator breaker is open and one or two poles of the breaker flash over, the resulting transformer neutral current is detected by the 50G relay without the delay that would be associated with negative-sequence or neutral backup relays. Again, CDs associated with the generator breaker failure should be set with sufficient sensitivity to detect this flashover condition.

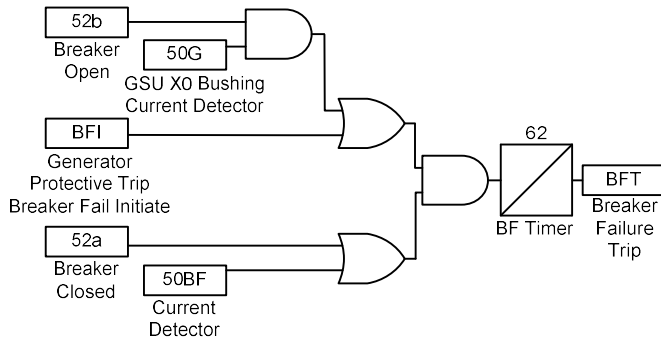

Fig. 7. Modified Breaker Failure Logic

For low-side generator breakers, instantaneous generator neutral overcurrent or neutral overvoltage elements are necessary to detect breaker flashover. Again, the relay output is supervised by the generator breaker open (52b) status and provides an additional start to the breaker failure scheme.

Generator breaker flashover may also be detected by breaker pole disagreement relaying. This relay monitors the three-phase currents flowing through the breaker and senses whether any phase is below a certain threshold level (indicating an open breaker pole) at the same time that any other phase is above a substantially higher threshold (indicating a closed or flashed-over pole). For breaker-and-a-half or ring-bus applications, the zero-sequence voltage ($3V_0$) across the breaker supervises the relay tripping to prevent false operation due to current unbalances caused by dissimilarities in phase bus impedances.

VII. CONCLUSION

This tutorial chapter summarizes breaker failure protection practices that are detailed in [1] and [2] with more explanation of basic concepts. Breaker failure schemes are generally connected to energize a lockout relay that trips the necessary backup breakers, initiates the transfer tripping of necessary remote breakers, and isolates the generator.

For additional information related to breaker failure protection, please refer to [3] and [4].

VIII. REFERENCES

- [1] IEEE Power System Relaying Committee Report, "Summary Update of Practices on Breaker Failure Protection," *IEEE Transactions on Power Apparatus and Systems*, vol. PAS-101, issue 3, pp. 555–563, Mar. 1982.
- [2] *IEEE Guide for AC Generator Protection*, IEEE Standard C37.102-2006.
- [3] *IEEE Guide for Breaker Failure Protection of Power Circuit Breakers*, IEEE Standard C37.119-2005.
- [4] C. J. Mozina, R. F. Arehart, J. Berdy, J. J. Bonk, S. P. Conrad, A. N. Darlington, W. A. Elmore, H. G. Farley, D. C. Mikell, G. R. Nail, H. O. Ohmstedt, A. C. Pierce, E. T. Sage, D. E. Sanford, L. J. Schulze, W. M. Strang, G. Stranne, F. Tajaddodi, and T. Wiedman, "Inadvertent Energizing Protection of Synchronous Generators," *IEEE Transactions on Power Delivery*, vol. 4, issue 2, pp. 965–977, Apr. 1989.

Abnormal Frequency Protection

Gabriel Benmouyal and Stephen P. Conrad

Abstract—Both the generator and turbine are limited in the degree of abnormal frequency operation that can be tolerated. At reduced frequencies, there will be a reduction in the output capability of a generator. Turbines, especially steam and gas turbines, are considered to be more restrictive to operation at reduced frequencies than the generator because of resonances in the turbine blades. Departure from rated speed under load will bring stimulus frequencies closer to one or more of the natural frequencies of the various blades, and there will be an increase in vibratory stresses. As vibratory stresses increase, damage is accumulated, which may lead to cracking of some parts of the blade structure.

The primary underfrequency protection for turbine generators depends upon the utility's philosophy. If turbine safety is the primary concern, applying turbine underfrequency protection is one option. Alternatively, the implementation of automatic load-shedding programs on the power system is another. These load-shedding programs should be designed so that for the maximum possible overload condition, sufficient load is shed to quickly restore system frequency to near normal. When automatic load shedding is implemented, backup protection for underfrequency conditions is provided by the use of one or more underfrequency relays and timers on each generator. The underfrequency relays and timers are usually connected to trip the generator.

I. INTRODUCTION

When a power system is in stable operation at normal frequency, the total mechanical power input from the prime mover to the generators is equal to the sum of the connected loads and all real power losses in the system. A significant upset of this balance causes an abnormal system frequency condition. Abnormal frequency conditions can cause generators to trip, tie lines to open from overload, or parts of the system to separate because of power swings and resulting instability. This could result in the power system separating into one or more electrically isolated islands.

Most utilities have implemented an automated load-shedding program to prevent total system collapse as well as minimize the possibility of equipment damage during an abnormal frequency operating condition. These load-shedding programs are designed to:

- Shed just enough load to relieve the overloading on connected generation.
- Minimize the risk of damage to the generating plant.
- Mitigate the possibility of cascading the event as a result of a unit underfrequency tripping.
- Quickly restore system frequency to near normal.

The following two types of abnormal frequency conditions can occur on a power system:

- Underfrequency condition occurs on a power system as a result of a sudden reduction in input power through the loss of the generator(s) or key intertie(s) importing power. This can produce a decline in the speed of the generator, resulting in system frequency decline.
- An overfrequency condition occurs as a result of a sudden loss of load or key interties exporting power. Loss of electrical power due to the initial load drop causes acceleration of units and a resulting increase in system frequency.

The following are two major considerations associated with operating a generating plant at an abnormal frequency:

- Protection of equipment from damage that could result from operation at an abnormal frequency.
- Prevention of inadvertent tripping of the generating unit for a recoverable abnormal frequency condition that does not exceed the plant equipment design limits.

The major parts of a generating plant affected by abnormal frequency operation are generator, transformers, turbine, and the station auxiliary loads. The effect of abnormal frequency conditions on these major parts of a generation plant will be discussed in this section, along with recommended protection.

Keep in mind that much of the information concerning the operation of turbines and generators at off-nominal frequency is proprietary and may vary from one manufacturer to another. In view of that situation, it is recommended that the relevant information for a particular piece of equipment or installation regarding its frequency operation capabilities should be obtained from the manufacturer. It is now customary practice for the equipment manufacturer to give final approval of the frequency protection scheme for a turbine or generator. In most applications, generator underfrequency relay settings, both minimum operate and time delay, can coordinate with system underfrequency load-shedding programs. This coordination should enhance generator/turbine protection and maintain system reliability.

II. CONFORMANCE TO IEC 60034:2007

Some turbine generators are designed to accommodate the frequency voltage characteristics from IEC 60034-3:2007, Rotating Electrical Machines – Part 3. This standard requires generators to deliver continuously rated output at the rated power factor over the ranges of ± 5 percent in voltage and ± 2 percent in frequency, as shown by the shaded area in Fig. 1.

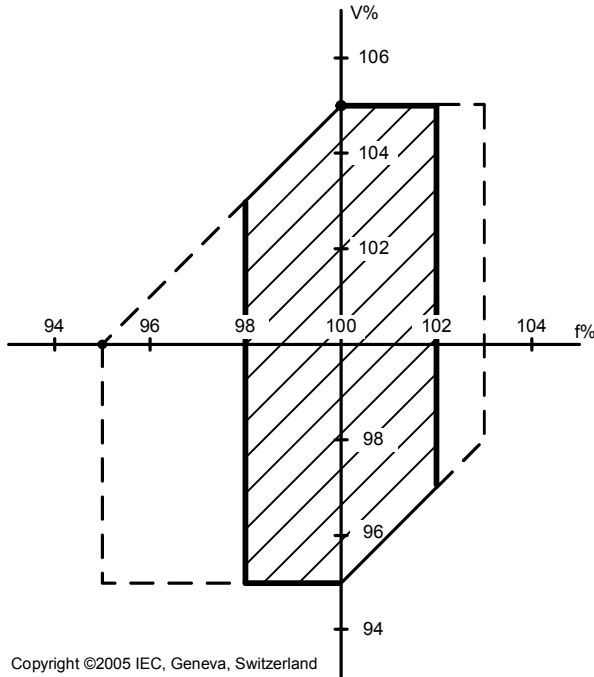

Fig. 1. Operation Overranges of Voltage and Frequency [1]

IEC 60034-3:2007 recommends that operation outside the shaded area “be limited in extent, duration and frequency of occurrence.” A manufacturer could, therefore, impose severe time restrictions for the generator itself, particularly for operation below 95 or above 103 percent of rated frequency (respectively 57 or 61.8 Hz on a 60 Hz basis) and, to a lesser extent, for operation outside of the continuous range of 98 to 102 percent of rated frequency.

In view of these considerations, a manufacturer may require, for the generator only, frequency operational limits in the form of time-frequency characteristics. In such situations, the principal goal of frequency protection schemes is to return the frequency to the continuous IEC operating frequency range (98 to 102 percent of rated frequency) as soon as possible and minimize operation outside of this range in extent, duration, and in concert with load-shedding practices.

III. ABNORMAL FREQUENCY OPERATION IN STEAM GENERATING PLANTS

A. Generator Over-/Underfrequency Capability

The only known restriction imposed by standards on the abnormal frequency operation of synchronous generators is conformance to IEC 60034-3:2007 as noted in the previous paragraph. When restrictions imposed by this standard are not

relevant, the following general considerations are still applicable.

The permissible short-time operating levels for both the stator and rotor for cylindrical-rotor synchronous generators are specified in IEEE C50.13, Standard for Cylindrical-Rotor 50 Hz and 60 Hz Synchronous Generators Rated 10 MVA and above. The limitations on generators operating in an underfrequency condition are less restrictive than those placed on the turbine. However, when generator protection is required, it has been industry practice to provide underfrequency protection. Overfrequency is usually the result of a sudden reduction in load and therefore is usually associated with light-load or no-load operation. During overfrequency operation, machine ventilation is improved, and the flux densities for a given terminal voltage are reduced. Therefore, operation within the overfrequency limits of the turbine will not produce generator overheating so long as rated kVA and rated voltage are not exceeded.

If the generator voltage regulator is left in service at significantly reduced frequencies, the volts-per-hertz limitation of a generator could be exceeded. However, most incidents of excessive volts per hertz occur for reasons other than reduced frequency operation and are addressed in Chapter 3.2.

B. Turbine Over-/Underfrequency Capability

The primary consideration in operation of a steam turbine under load at other than the synchronous frequency is the protection of the long tuned blading in the low-pressure turbine element. Fig. 2 illustrates a composite representing the most restrictive limits for large steam turbine partial- or full-load operating limitations during abnormal frequency [2]. Operation of these stages under load at a speed that causes a coincidence of blading natural frequency band will lead to blading fatigue damage and ultimately blading failures. This problem can be particularly severe when negative-sequence current flows through the generator armature, thereby exciting torsional frequencies, with blade resonance around 120 Hz.

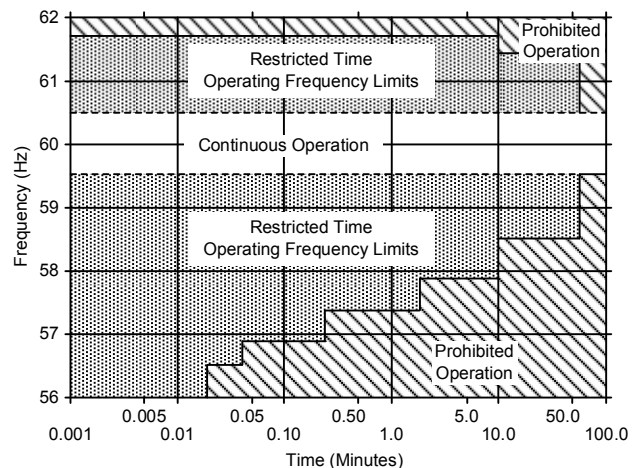

Fig. 2. Hypothetical Composite of Steam Turbine Partial- or Full-Load Operating Limitations During Abnormal Frequency [2]

Overfrequency protection is generally not applied because governor runback controls or operator actions are counted upon to correct the turbine speed. However, considerations must be given to the impact on overspeed protection and isolation of the unit during an overfrequency condition. This is necessary to ensure coordination and protection for turbine blades for overfrequency conditions. Because the operating limits are the same as shown above the 60 Hz line in Fig. 2, protection methods for preventing turbine operation outside the prescribed limits will be restricted to underfrequency protection. System load-shedding schemes, when properly designed and coordinated with the underfrequency protection, provide the initial turbine underfrequency protection.

Appropriate load shedding can cause the system frequency to return to normal before the turbine abnormal limits are exceeded. Automatic load-shedding underfrequency relays are used to shed the required amount of load needed to maintain a load-to-generation balance during a system overload.

Therefore, operation at frequencies other than rated or near-rated speed is time-restricted to the limits for various frequency bands published by each turbine manufacturer for various blade designs. The abnormal frequency limits are generally based on worst-case conditions as follows:

- The natural frequencies of blades within a stage differ because of manufacturing tolerance.
- The fatigue may increase with normal operation for reasons such as pitting, corrosion, and erosion of the blade edges.
- The limit should also recognize the effect of additional loss of blade life incurred during abnormal operating conditions not associated with underspeed or overspeed operation.

System islands could be formed because of load-shedding schemes or unforeseen circumstances. Underfrequency protection should be considered for the turbine generator to reduce the risk of steam turbine damage when there is a risk of creating such an island area. In addition, turbine generator underfrequency protection provides backup protection against failure of the load-shedding system.

The following design criteria are suggested as guidelines in development of an underfrequency protection scheme:

- Trip points and time delays should be established based on the manufacturer's turbine abnormal frequency limits.
- The turbine generator underfrequency tripping relays should be coordinated with the system automated load-shedding program.

- Failure of a single underfrequency relay should not cause an unnecessary trip of the machine.
- Failure of a single underfrequency relay to operate during an underfrequency condition should not jeopardize the overall protective scheme.
- Relays should be selected based on their accuracy, speed of operation, and reset capability.
- The turbine underfrequency protection system should be in service whenever the unit is synchronized to the system or while separated from the system but supplying auxiliary power.
- Separate alarms should be provided to alert the operator of a system frequency less than normal and an indication of a pending trip of the unit.

The first step in designing an underfrequency protection scheme is determining the turbine's abnormal frequency operating characteristic. Consultation with the manufacturer should provide the initial design parameters. Once the number of frequency steps is known, the time delay for each step must be determined. Because the allowable underfrequency operation time cannot be identified exactly, some margin should be included in the time delay. This margin allows tripping of the unit prior to damage, with the opportunity to inspect the turbine at the owner's convenience during a future outage. This allows for application of underfrequency protection, even if the unit has been in operation for many years without having accumulated previous underfrequency operational data. The time-delay margins should consider the importance of the unit, the susceptibility of the system to an underfrequency event, and the operating agreements with local or regional power authorities. A 50 to 90 percent range of the allowable time per expected event over the blading life is reasonable. Settings of 50 percent should be considered if the turbine is in poor condition, if there is a high possibility of an underfrequency event, or if the unit is not system critical. If the unit is in good condition, an underfrequency event is unlikely, and the unit is critical to the system, a setting near 90 percent of the allowable underfrequency time should be considered. Recognize that some underfrequency relay timers have an instantaneous reset once the frequency rises above the trip setting, while others accumulate the underfrequency operate time in a memory function (zero reset). The time-delay setting should be a smaller percentage of the allowable time if the relay provides instantaneous reset, whereas the zero-reset relay can be set at a greater percentage of the allowable time.

Fig. 3 demonstrates an underfrequency relay setting. The example indicates the turbine is capable of continuous operation at frequencies above 58.5 Hz and is limited to a maximum of 10 minutes accumulated over the blading life at 56.0 Hz. These are operating conditions with the turbine at load. The underfrequency relay trip-point setting should be set just above 56.0 Hz to allow for relay margin. A setting of 56.2 could be selected. A time-delay setting of 7 minutes could be used if the unit is in fair condition and not critical to the operation of the system and it is acceptable to lose 70 percent of the fatigue life of the blading. If the unit is in good condition and is critical to the system, a longer time delay of 9 minutes could be used to allow the maximum opportunity for system recovery prior to tripping the unit, assuming these events are very rare so that 90 percent of the fatigue life can be expended on it. An alarm should be provided when the underfrequency relay begins to time out, providing operating personnel a warning of the impending underfrequency trip.

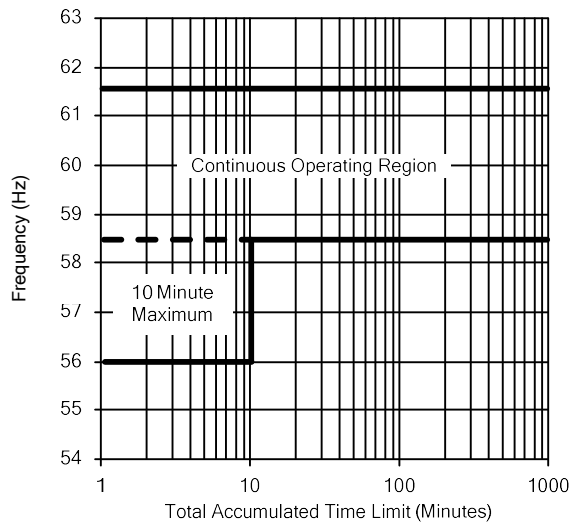

Fig. 3. Example of Turbine Abnormal Frequency Limitations and Settings

If IEC 60034-3:2007 is applicable, as described earlier, time-frequency protection may be required by a manufacturer for the turbine generator. In such situations, the more restrictive of the generator and turbine frequency requirements should be used to determine the appropriate frequency settings for underfrequency relaying. The frequency capability of the generator, when applicable, must be considered in the development of the frequency relay protection scheme.

C. Underfrequency Considerations for Power Steam Plant Auxiliary

The ability of the steam supply system to continue operation during an extended period of underfrequency operation depends on the margin in capacity of the auxiliary

motor drives and shaft-drive loads. The most limiting auxiliary equipment is generally the boiler feed pumps, circulating water pumps, and condensate pumps, because each percent of speed reduction causes a larger percent loss of capacity. The critical frequency at which the performance of the pumps will affect the plant output will vary from plant to plant. Consequently, the minimum safe frequency level for maintaining plant output is dependent on each plant and the equipment design and capacity associated with each generating unit.

Protection against underfrequency operation is usually allocated to the thermal protective equipment, but more refined protection is possible using a frequency-sensitive relay or a volt-per-hertz relay, which will measure actual system conditions.

IV. ABNORMAL FREQUENCY OPERATION FOR COMBUSTION-TURBINE GENERATORS

The limitations for combustion-turbine generators (CTGs) are similar in many respects to the limitations for steam-turbine generators. However, certain differences in the design and application of CTGs may result in different protective requirements.

A combustion turbine may lose air flow if an attempt is made to maintain full output during underfrequency conditions. Loss of air flow would result in eventual unit trip on blade over temperature. CTGs are equipped with a control system that automatically unloads the unit by reducing fuel flow as speed decreases. This control has the overall effect of protecting the turbine blade from damage and the generator from overheating during underfrequency operation of the unit.

In general, CTGs have a greater capability than steam units for underfrequency operation, particularly if the control system includes a load runback feature. Continuous operation of the CTGs ranges from 56 to 60 Hz, with the turbine blades being the limiting factor. These factors, plus those discussed earlier, suggest an underfrequency protection scheme with a single trip set point at or below the lowest underfrequency trip set point for the steam units in the vicinity. The following guidelines should be used when applying underfrequency protection to combustion turbines:

- Use one underfrequency relay per unit supplied by the unit voltage transformers (VTs).
- If added security is desired, supervise tripping with a second underfrequency relay. This relay may be common to several units.
- Be aware of existing underfrequency protection provided by the manufacturer in the unit's control system. Coordination of settings and trip logic may be required to avoid interference with external protection.

Fig. 4 shows a typical example of the combustion turbines under-/overfrequency limits and associated times.

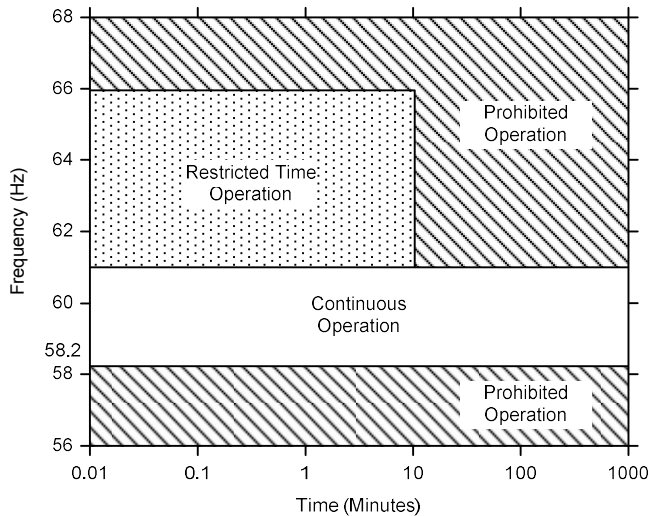

Fig. 4. Typical Combustion Turbine Operational Limits

V. ABNORMAL FREQUENCY OPERATION FOR COMBINED-CYCLE GENERATING UNITS

In a combined-cycle generating installation, which is a combination of a combustion-turbine unit and a steam turbine unit, underfrequency limitations will be subject to those described in the previous sections associated with each type of unit. A recommended approach for protecting a combined-cycle installation is to provide separate underfrequency protective schemes for each unit of the combined-cycle installation. The method used should follow the recommendations indicated in the section for each unit.

In an example of a typical combined-cycle unit, under-/overfrequency limits and associated times would be similar to the combustion unit shown in Fig. 4.

VI. ABNORMAL FREQUENCY OPERATION FOR HYDROELECTRIC GENERATING UNITS

Hydraulic-powered turbines can usually tolerate much wider frequency deviations than steam or combustion turbines. Underfrequency protection is not normally required for turbine protection. The maximum rate of change of water flow through the turbine is often limited by maximum or minimum pressures that can be tolerated in the penstocks.

The limited rate at which the water inlet gate can be closed may result in overspeeds in excess of 150 percent of nominal speed upon sudden loss of load. While such high speeds may be tolerated for a short while, the units should be brought back to nominal speed within several seconds by governor action. In the event of governor failure, the turbine generator may “run away” at speeds approaching 200 percent of nominal. Overfrequency protection may be applied on hydroelectric generators to backup or replace mechanical overspeed devices. These relays may be set at a lower frequency than the maximum occurring during load rejection but with appropriate time delay to override normal governor action. If governor

action does not bring the frequency down within an appropriate time, the overfrequency protection operates.

Operation of the overfrequency protection may indicate a malfunction in the turbine gate control system. Therefore, this protection may be connected to close emergency intake gates or valves upstream of the main turbine inlet gates.

Because of the large frequency variations that may be expected during sudden load changes on hydroelectric generators, customer loads, which may be connected to islands with such generation, may be protected by under-/overfrequency protection. These relays may be set with narrower windows and shorter time delays than needed for protection of the generating plant. The relays are sometimes connected to VTs in the generating plant. Such “quality protection” devices are not to be confused with generator protection. They are intended to protect the quality of supply to customers and are usually connected to disconnect the loads, perhaps with incidental shutdown of the generator.

Because the setting requirements for quality protection are quite independent from the requirements for turbine or generator protection, different relays may be required for the two functions.

VII. ABNORMAL FREQUENCY OPERATION FOR NUCLEAR GENERATING PLANTS

A. Turbine Generator Over-/Underfrequency Capability

In general, the turbine generator considerations that affect operations of the plant are the same as those discussed in Section III on steam generating plants.

B. Underfrequency Considerations for Nuclear Power Plant Auxiliaries

The major effect of an underfrequency condition on the plant auxiliary system causes a reduction in various outputs of electrical coolant pump flows. Operation as a result of reduced flows in parts of the system may be detrimental to plant equipment. Nuclear plant designs that are based on pressurized water reactor (PWR) and boiling water reactor (BWR) are analyzed separately because their responses to abnormal frequency operation differ.

1) PWR Plants

Abnormal frequencies on PWR units affect the reactor coolant pump speed, which varies with the power system frequency. If the frequency at the plant collapses, the reactor will trip automatically when this condition results in reduced coolant flow through the reactor. When the reactor trips, the generator also trips, and the reactor shuts down with the reactor coolant pump connected to the power system. If the frequency continues to decay at a rate greater than the design coast-down rate of the reactor coolant pump, the reactor coolant flow rate will be forced down by the decaying system frequency. This condition could result in a challenge to the safe operation of the plant. This is one of the most serious impacts that an underfrequency condition can impose on a PWR plant.

In addressing this condition, one possible solution is to isolate the reactor coolant pumps from the power system if the system frequency decay exceeds the pump design coast-down rate. Accomplishing this task requires the application of an underfrequency relay to trip the reactor and generator at a frequency level that will allow an isolated reactor coolant pump to meet its coast-down operational performance requirements. The following parameters should be considered when applying underfrequency protection to a PWR plant:

- The designed departure from the nuclear boiling ratio of the plant.
- The size of the coolant system with respect to the reactor core.
- The maximum rate of power system frequency decay that may be encountered.
- The rating of the core with respect to loading.
- Coordination with power system load-shedding schemes.
- System voltage conditions that exist at the time of a system frequency decline.

2) BWR Plants

Some BWR units employ nonseismically qualified motor-generator sets to supply power to the reactor protection systems. To ensure that these systems can perform their intended safety functions during a seismic event for which an underfrequency condition of the motor-generator sets or alternate supply could damage components of these systems, redundant underfrequency relays are provided. This protection is provided between the alternate power source and the reactor protection system buses. Operation of either or both of the underfrequency relays associated with a reactor protection system will cause a half scram of the unit. If one or both of the underfrequency relays operate on each of the reactor system protection buses, a full scram of the unit occurs. Several factors should be considered in the setting of the underfrequency relays for BWR units:

- The tolerance characteristic of the underfrequency relay.
- The slip characteristic of the motor-generator sets.
- The characteristics of the power system load-shedding schemes.

VIII. REFERENCES

- [1] *Rotating Electrical Machines – Part 3: Specific Requirements for Synchronous Generators Driven by Steam Turbines or Combustion Gas Turbines*, IEC Standard 60034-3, Nov. 2007.
- [2] *IEEE Guide for Abnormal Frequency Protection for Power Generating Plants*, IEEE Standard C37.106-2003, 2004.

Overexcitation and Overvoltage Protection

Randy Hamilton and Michael Thompson

Abstract—IEEE standards state that generators shall operate successfully at rated kVA for frequency and voltage levels within specific limits. Deviations in frequency and voltages outside these limits can cause thermal and dielectric distress, which can cause damage within seconds. Monitoring and protection schemes need to be provided for overexcitation and overvoltage deviations.

I. INTRODUCTION

Overexcitation of a generator or any transformers connected to the generator terminals will typically occur whenever the ratio of the voltage to frequency (V/Hz) applied to the terminals of the equipment exceeds design limits. IEEE standards have established the following limits [1] [2] [3]:

- Generators, 1.05 pu at the output terminals (generator base)
- Transformers, 1.05 pu at the output terminals (on the transformer secondary base) at rated load (power factor of 80 percent or higher and frequency at least 95 percent of rated value) or 1.1 pu at no load (at the high-voltage terminals)

These limits apply unless equipment manufacturers state otherwise. When these V/Hz ratios are exceeded, saturation of the magnetic core of the generator or connected transformers can occur, and stray flux will be induced into nonlaminated components. These components are not designed to carry flux, and damage can occur within seconds. It is general practice to provide V/Hz relaying to protect generators and transformers from these excessive magnetic flux density levels. This protection is typically independent of V/Hz control in the excitation system.

Note that overexcitation protection on a generator or its connected transformers is different from field overexcitation protection. Field overexcitation protection, which usually coordinates the overexcitation limiter (OEL) of a synchronous machine, protects the field winding from thermal overload due to field overcurrent.

Excessive overvoltage of a generator will occur when the level of electric field stress exceeds the insulation capability

of the generator stator winding, connected transformers, bushings, and surge arrestors. The V/Hz protection cannot be relied upon to detect all overvoltage conditions. If the overvoltage is the result of a proportional increase in frequency, the V/Hz relaying will miss the event because the V/Hz ratio remains constant. It is general practice to provide overvoltage relaying to alarm, or in some cases, trip the generators from these high electric stress levels.

II. OVEREXCITATION FUNDAMENTALS

A magnetic field is essential to convert mechanical power to electrical power in a generator. It couples windings together to step-up or step-down voltages. The core of a generator stator or transformer is designed to provide the magnetic flux at a certain limit. The output voltage is proportional to the rate of change of the flux.

Assuming the flux is in the form of:

$$\phi(t) = \phi_{\max} \sin(2\pi ft + \theta) \quad (1)$$

the induced voltage is:

$$\begin{aligned} v(t) &= N \frac{d\phi}{dt} = 2\pi f N \phi_{\max} \cos(2\pi ft + \theta) \\ &= \sqrt{2} V \cos(2\pi ft + \theta) \end{aligned} \quad (2)$$

and the core flux requirement is:

$$\phi_{\max} = \frac{\sqrt{2} V}{2\pi f N} \quad (3)$$

The maximum flux in the core is proportional to voltage, inversely proportional to frequency, and can be calculated based on V/Hz.

Relaying for overexcitation, or V/Hz (per-unit voltage divided by per-unit frequency), protects generators and transformers from excessive magnetic flux density levels. High flux density levels result from various operating conditions. At these high levels, the magnetic iron paths designed to carry the normal flux saturate, and flux begins to flow in leakage paths not designed to carry it.

Fig. 1 is an axial cross-section of a turbine generator, showing the main and leakage magnetic fields. Leakage magnetic fields are most damaging at the ends of the core of the generator where the fringing magnetic field can induce high eddy currents in the solid core assembly components and the end-of-core laminations [4] [5]. This results in higher losses and heating in those components. A typical construction for the end of a generator stator core is shown in Fig. 2.

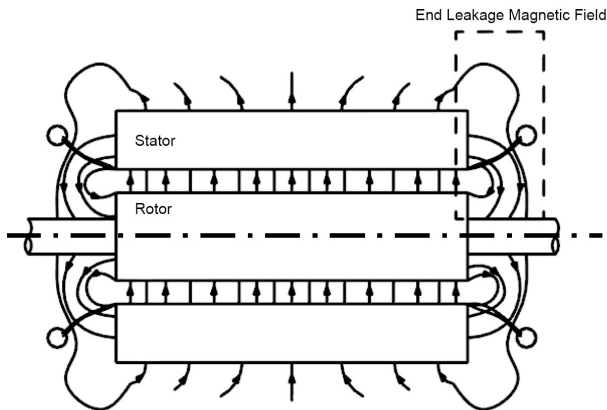

Fig. 1. Axial Cross-Section of Turbine Generator Showing Magnetic Field Paths

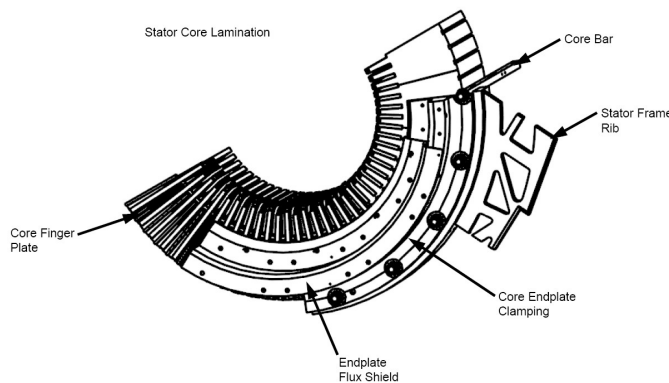

Fig. 2. Typical End Construction of Generator Stator Core

In addition to higher temperatures, eddy currents also cause interlaminar voltages that could further degrade the insulation. At extremely high levels of overexcitation, these induced voltages can be coupled to the stator laminations because of the manner in which the stator cores are designed, assembled, and clamped together. This severe over fluxing can breakdown interlaminar insulation, followed by rapid localized core melting and failure. Fig. 3 shows these current paths. If the thin insulation of the laminations is broken down by high temperatures or voltages, severe iron damage results. These high temperatures and voltages can result in damage within seconds. After this damage occurs, the core is useless. Even normal core magnetic flux density levels will only increase the amount of burning and melting. Equipment downtime will be significant. Damage is more severe than most winding failures, and the repair may require removal of the entire winding and restacking a portion of the core.

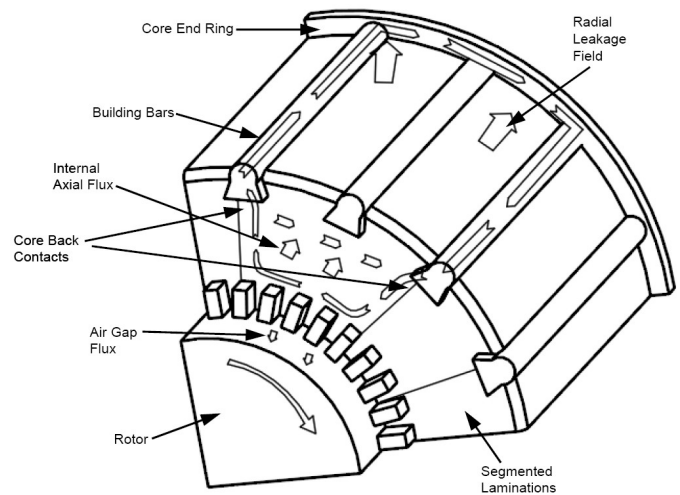

Fig. 3. Leakage Fluxes and Currents at the End of the Core

Damage due to excessive V/Hz operation most frequently occurs when the unit is offline, prior to synchronization. The potential for overexcitation of the generator increases dramatically if operators manually prepare the unit for synchronization, particularly if overexcitation alarm or inhibit circuits are inadequate or voltage transformer (VT) circuits are improperly made up. For example, a large nuclear generator failed when an improperly racked-in VT caused the voltage signal to be far less than the actual machine voltage. This signal was read by the operator manually applying field excitation. The core failed in less than one minute. This situation could also have occurred with an automatic scheme if proper safeguards were not designed into the protective system or if these measures failed.

It is also possible for a unit to experience excessive V/Hz operation while synchronized to the grid. A common belief is that the interconnected power systems in North America are infinite-bus systems and that it is virtually impossible to significantly raise unit voltages above rated operating voltage. This is not true for all units; improper full-boost operation by a faulty voltage regulator has been known to significantly raise local system voltages. Several scenarios may develop that can cause an overexcitation condition when the unit is connected to the system [6] [7]:

- Loss of nearby generation can affect grid voltage and var flow, causing a disturbance that shows itself as a voltage drop. In an attempt to maintain system voltage, the remaining generator excitation systems may attempt to boost terminal voltage to the set point limits of the excitation control while the tripped generation is reconnected. If failure of excitation control occurs during this interval, an overexcitation event takes place.
- A generator may be operating at rated levels to supply a high level of vars to the system. Unit voltage may still remain near rated grid levels because of interconnections. A sudden loss of load or interconnections can cause unit voltage to rise

suddenly. An overexcitation event will occur if the generator excitation control does not respond properly.

- Large capacitive load can activate the leading var limit function in most automatic regulators. When this function is activated, an automatic regulator will increase field current, and the generator voltage is increased. When a generator is isolated on a capacitive load, increasing the generator voltage increases var output of the capacitive load. This action may result in an uncontrolled rise to maximum excitation output and overexcitation of the generator and its connected transformers.
- Self-excitation can occur in generators due to the opening of a remote system breaker when the unit is connected to the system via long transmission lines. If the charging admittance at the generator terminals is greater than the quadrature-axis admittance $1/X_q$, the positive feedback nature of the voltage regulator control action can cause a rapid voltage rise. Self-excitation is normally associated with hydroelectric generators, because the unit may experience overspeed of 200 percent during load rejections [8].

III. OPERATING LIMITS ON EQUIPMENT

Equipment limitations are an important consideration in setting the V/Hz protection for a generating unit. IEEE standards have guidelines on limits for excessive V/Hz and overvoltage of generators and associated unit transformers, including generator step-up (GSU) and unit auxiliary transformers (UATs) [9] [10]. These are summarized in Section I.

When setting overvoltage protection, certain standards govern minimum requirements. Cylindrical-rotor turbine generators must be capable of operation up to 105 percent of rated voltage. Similar variations in voltage are also set for hydroelectric generators [3]. Power transformers are only required to operate up to 110 percent of rated voltage at rated frequency depending on loading levels [2]. The V/Hz capability is measured at the transformer output. For a GSU transformer, the measurement point is at the high-voltage terminals.

Equipment damage due to excessive V/Hz is primarily caused by component overheating, which is dependent on the duration of the event. From the relationships between leakage fields and heating, curves can illustrate the limits on the magnitude and duration of V/Hz events. Manufacturers will generally provide curves for their equipment showing the limits of permissible operation in terms of percent of normal V/Hz versus time. However, manufacturers have difficulty precisely defining damage curves for heating in components that are not normally exposed to excessive stray flux except during an overexcitation event. Therefore, they may instead provide a recommended protection curve. Fig. 4 and Fig. 5 show typical curves for a generator and a power transformer.

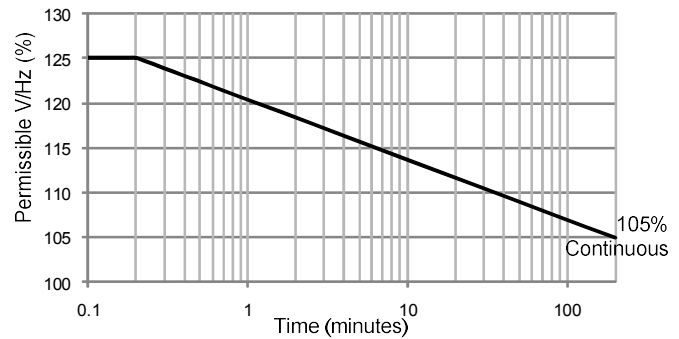

Fig. 4. Typical Limiting Curve for V/Hz Operation for a Generator [11]

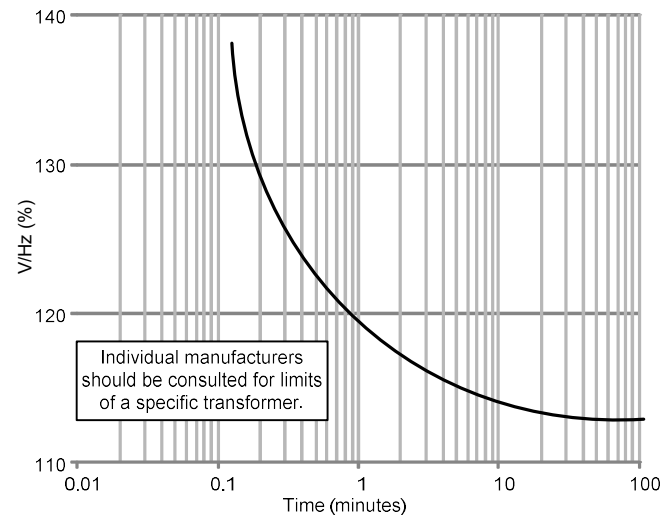

Fig. 5. Typical Limiting Curve for V/Hz Operation for a Power Transformer [10]

In setting the V/Hz protection for a generating unit, it is important that the permissible operating curves for generators and transformers be put on a common voltage base. This is necessary because, in some cases, the voltage rating of a GSU transformer's low-voltage winding is slightly less than the generator's. The resulting turns ratio partially compensates for the voltage drop in the leakage impedance due to load current. The voltage base normally used is the generator terminal voltage, because the VTs typically used for the relay voltage signal are connected to the unit between the generator and UAT and GSU transformers. Note that unless otherwise specified, the curve applies for time intervals of less than 10 minutes [1].

Equipment damage for excessive voltage alone is primarily caused by the breakdown of insulation due to dielectric stress. Overvoltage without overexcitation (V/Hz) can occur when a generator experiences overspeed due to load rejection, severe sudden fault, etc. An overexcitation does not occur in these cases because voltage and frequency increase in the same proportion; therefore, the V/Hz ratio remains constant. Manufacturers will generally provide voltage/time relationships for their equipment showing the limits of permissible operation. Because heat accumulation due to core

overexcitation reduces the dielectric strength of the stator winding insulation, the overvoltage accompanied by overexcitation has a compounding damaging effect to the winding insulation compared to the overvoltage condition alone.

In setting the overvoltage relaying for a generating unit, it is important that the permissible operating limits for generators and transformers be put on a common voltage base for the same reasons described for V/Hz relaying.

IV. PROTECTION SCHEMES AND CHARACTERISTICS

For V/Hz relaying, two general relay characteristics are used, definite-time and inverse-time. Fig. 6 and Fig. 7 show the basic relay characteristic and zone of protection for each type of relay. For newer microprocessor-based, inverse-time relays, two styles of inverse-time curve settings are available. One relay style allows the user to select specific points on the desired V/Hz-time curve for the user's particular application. The other relay style provides sets of V/Hz-time curves from which the user selects a specific curve, providing a best fit for this application.

Note that the V/Hz curves provided by manufacturers are often based on actual core limits. When such curves are applied at the equipment terminals, they represent a no-load condition. The application of such curves under load may be optimistic. When using V/Hz curves, the applicable conditions for the curve must be known [12].

There are three common protection schemes currently employed for V/Hz relaying in the industry. These schemes are single-level, definite-time; dual-level, definite-time; and inverse-time. One major disadvantage of employing a protection scheme that only utilizes definite-time relays is the tradeoff between equipment protection and operating flexibility. Fig. 8 shows a possible protection scheme using two V/Hz relays in a dual-level, definite-time scheme. Notice the unprotected areas where equipment limits could be exceeded and the areas where the relay characteristics restrict operation below equipment limits.

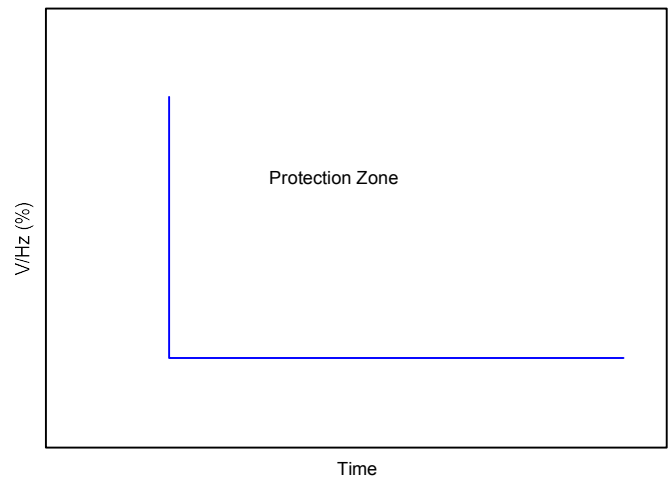

Fig. 6. Typical Definite-Time Relay Characteristic

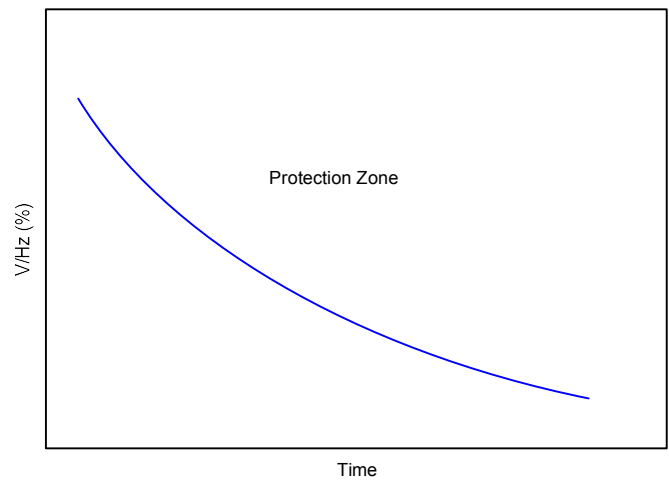

Fig. 7. Typical Inverse-Time Relay Characteristic

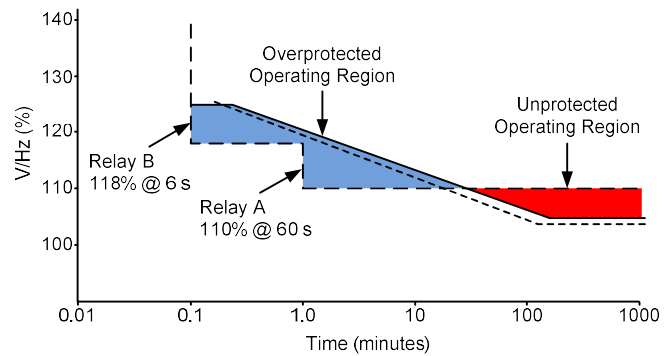

Fig. 8. Typical Relay Characteristic for a Dual-Level, Definite-Time V/Hz Protection

For this reason, inverse-time relays provide the optimal protection and operational flexibility because they coordinate better with the operational limits of the equipment. Fig. 9 shows a typical scheme using both inverse-time and definite-time relays. In the example shown in Fig. 9, the manufacturer recommended protection requires a definite-time element set to trip in 2 seconds above 118 percent V/Hz. The two-second delay allows time for the voltage regulator to correct an extreme overexcitation condition and still protect the unit from damage. The inverse-time element must be set to trip in 45 seconds or less, or to coordinate with the transformer overexcitation curve after placing it on the generator base, whichever is more restrictive. Pickup of the inverse-time element should be coordinated with the V/Hz limiter on the excitation control system. Because continuous operation above 105 percent is not allowed, an alarm element set to pick up at 105 percent with a short delay is also recommended [13].

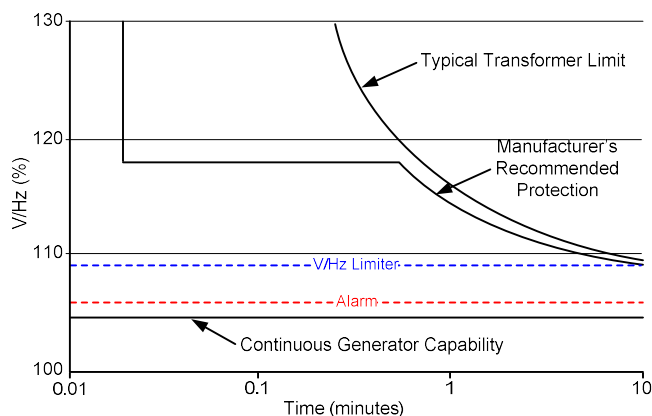

Fig. 9. Optimal Protection and Operational Flexibility is Provided by Using Both Inverse- and Definite-Time Elements

For overvoltage relaying, the pickup should be set above the maximum normal operating voltage, and the relay may have an inverse- or definite-time characteristic to give the regulator a chance to respond to transient conditions before tripping occurs. Additionally, an instantaneous element may be applied for very high overvoltages.

It is important that the overvoltage relaying has a flat frequency response, as frequency excursions can take place during the overvoltage event. This is of particular concern with hydroelectric installations that may have limits on the rate of gate closure imposed by hydraulic pressure in the penstocks. In such cases, these units may experience speed increases in the region of 150 percent during a full load rejection before governor action can reduce the speed.

V. CONNECTION OF V/Hz AND OVERVOLTAGE RELAYING

Many V/Hz relays are single-phase devices. Problems arise if the voltage signal for the relays is taken from a single generator VT. A blown fuse or an incomplete circuit connection when racking the VTs back into place can result in no voltage being sensed by the V/Hz relay and, therefore, no protection. For complete and redundant protection, VTs on different phases should be used for the multiple alarm and

relay functions. Some of the newer digital relays have alarming capabilities when potential to one or two inputs is lost. For overvoltage relaying, the same issues as V/Hz relaying apply.

VI. COORDINATION OF PROTECTION WITH AUTOMATIC VOLTAGE REGULATOR

Modern digital excitation systems not only provide field current for a synchronous machine but also include many supplementary controls, such as over- and underexcitation limiters, V/Hz and terminal voltage limiters, and often embed various other protection elements. It is common and recommended practice to have a separate relay at the generator terminal as a backup when the AVR (automatic voltage regulator) is in manual mode or not functional.

It is desirable to have V/Hz and overvoltage protection coordinate with the limiters in the digital excitation system. The limiters keep the generator outputs within the specified design capability. The setting of the V/Hz protection is set slightly above the excitation system V/Hz limit with a time delay to give the excitation system time to automatically adjust the excitation level to fix the core overexcitation problem. The overvoltage protection should be set similarly to coordinate with the terminal voltage limiter in the excitation system.

VII. TRIPPING PHILOSOPHY

Excessive V/Hz operation will result in equipment failure and should be treated as a severe electrical problem. As recommended in the IEEE C37.102, IEEE Guide for AC Generator Protection, the field and main unit breakers should be opened if the unit is synchronized [14]. For units without load rejection capability (unable to quickly ramp down in power and stabilize at a no-load point), the turbine should also be tripped. Prior to synchronization, alarm and inhibit circuits should be provided to prevent an operator from overexciting the generator.

For machines operating offline, the practice is to trip the field breaker only and not trip the turbine. As the problem is with the excitation system, it may be quickly remedied and the unit placed online without going through the full startup process. This is particularly advantageous on steam units with long startup times.

Two tripping schemes should be discouraged: opening only the field breaker on a V/Hz relay operation and sequentially tripping the turbine and then the generator. Some believe that an excessive V/Hz event is only possible with the unit offline and that their protection logic has the V/Hz relay opening only the field breaker for any operating condition. If an event occurs while the unit is synchronized to the grid, the field breaker will open, and the unit must depend on other protective devices to trip.

Sequential tripping of the unit is also not recommended. Sequential tripping implies a scheme whereby the prime mover (usually a turbine) is tripped by a device responding to some disturbance. The generator and field breakers are then

tripped by some other protective device(s), usually including a reverse-power relay, responding to the loss of the prime mover. Time delays inherent in sequential tripping schemes are long enough to result in severe equipment damage.

VIII. CONCLUSION

V/Hz and overvoltage relaying are applied to generating plants to alarm and trip. Although on the surface they may seem like very similar protections, they are not. A keen understanding of the causes for overexcitation and overvoltage events is necessary for the proper application and setting of this protection. Factors to consider include issues such as generator and transformer capabilities, excitation and governor responses, type of prime mover, and if the unit is online or offline for proper tripping action. These factors have been detailed in this section of the tutorial. To avoid severe damage to the apparatus for overexcitation and overvoltage, this protection should be installed and properly applied.

IX. REFERENCES

- [1] *IEEE Standard for Cylindrical-Rotor 50 Hz and 60 Hz Synchronous Generators Rated 10 MVA and Above*, IEEE Standard C50.13-2005.
- [2] *IEEE Standard for Standard General Requirements for Liquid-Immersed Distribution, Power, and Regulating Transformers*, IEEE Standard C57.12.00-2006.
- [3] *IEEE Standard for Salient-Pole 50 Hz and 60 Hz Synchronous Generators and Generator/Motors for Hydraulic Turbine Applications Rated 5 MVA and Above*, IEEE Standard C50.12-2005.
- [4] P. O. Bobo, J. W. Skooglund, and C. L. Wagner, "Performance of Excitation Systems Under Abnormal Conditions," *IEEE Transactions on Power Apparatus and Systems*, vol. PAS-87, issue 2, pp. 547–553, Feb. 1968.
- [5] G. W. Alexander, S. L. Corbin, and W. J. McNutt, "Influence of Design and Operating Practices on Excitation of Generator Step-Up Transformers," *IEEE Transactions on Power Apparatus and Systems*, vol. PAS-85, issue 8, pp. 901–909, Aug. 1966.
- [6] D. W. Smaha (Chair), "Impact of HV and EHV Transmission on Generator Protection," *IEEE Transactions on Power Delivery*, vol. 8, issue 3, pp. 962–974, Jul. 1993.
- [7] M. S. Baldwin, W. A. Elmore, and J. J. Bonk. "Improved Turbine-Generator Protection for Increased Plant Reliability," *IEEE Transactions on Power Apparatus and Systems*, vol. PAS-99, issue 3, pp. 982–989, May 1980.
- [8] S. Patel, K. Stephan, M. Bajpai, R. Das, T. J. Domin, E. Fennell, J. D. Gardell, I. Gibbs, C. Henville, P. M. Kerrigan, H. J. King, P. Kumar, C. J. Mozina, M. Reichard, J. Uchiyama, S. Usman, D. Viers, D. Wardlow, and M. Yalla, "Performance of Generator Protection During Major System Disturbances," *IEEE Transactions on Power Delivery*, vol. 19, issue 4, pp. 1650–1662, Oct. 2004.
- [9] *IEEE Guide for Abnormal Frequency Protection for Power Generating Plants*, IEEE Standard C37.106-2003.
- [10] *IEEE Guide for Protective Relay Applications to Power Transformers*, IEEE Standard C37.91-2008.
- [11] R.E. Warner, T. L. Dillman, and M. S. Baldwin, "Off-Frequency Turbine-Generator Unit Operation," proceedings of the American Power Conference, vol. 38, p. 578, Chicago, IL, Apr. 1976.
- [12] D. Reimert, *Protective Relaying for Power Generation Systems*. Boca Raton, FL: CRC Press, 2006.
- [13] GE Energy, "Generator Protection," General Electric Company, GEK 755121, p. 13, revised Aug. 2009.
- [14] *IEEE Guide for AC Generator Protection*, IEEE Standard C37.102-2006.

Underexcitation/Loss-of-Excitation Protection

Murty V. V. S. Yalla and Juan Gers

Abstract—Partial or total loss of field on a synchronous generator is detrimental to both the generator and the power system to which it is connected. This condition should be detected and the generator isolated from the system to avoid generator damage. An undetected loss-of-field condition can also have a devastating impact on the power system. The impact causes a loss of reactive power support and creates substantial reactive power drain. On large generators, this condition can contribute to or trigger an area-wide, system-voltage collapse. This section of the tutorial discusses the generator loss-of-field characteristics and schemes to protect the generator from loss-of-field conditions.

I. INTRODUCTION

A synchronous generator requires adequate dc voltage and current to its field winding to maintain synchronism with a power system. There are many types of exciters that are used in the industry, including rotating dc exciters with conventional commutators, rotating brushless rectifier sets, and static exciters.

The generator capability curve shown in Fig. 1 provides an overview of synchronous machine operations. Normally, the generator field is adjusted so that the required reactive power as well as the real power is delivered to the power system. If the excitation level is reduced or the excitation system is lost, the generator absorbs reactive power from the power system rather than supplying it. The generator now operates in the underexcited region of the capability curve. Generators have low or reduced stability in this area. If a total loss of field occurs and the system can supply sufficient reactive power without a large terminal voltage drop, the generator may run as an induction generator. The change from normal overexcited operation to underexcited operation upon loss of field is not instantaneous but occurs over a period of time that extends over several seconds. The duration depends on the generator output level and the capability of the system to which the generator is connected.

The generator capability curve in Fig. 1 outlines the operating generator limits. In the normal operating region, the limiting factors are the thermal limits of the rotor and stator. In the underexcited area, the limiting factor is the heating of the stator end iron. The setting of the exciter-regulator control is coordinated with the steady-state stability limit (SSSL) of the generator. This limit is a function of the generator impedance, system impedance, and generator terminal voltage. Reference [1] provides details on how to plot this curve. The generator underexcited limiter control should prevent the exciter from reducing the field below the SSSL. Partial or full loss of field can result in the generator operating outside of the underexcited limits.

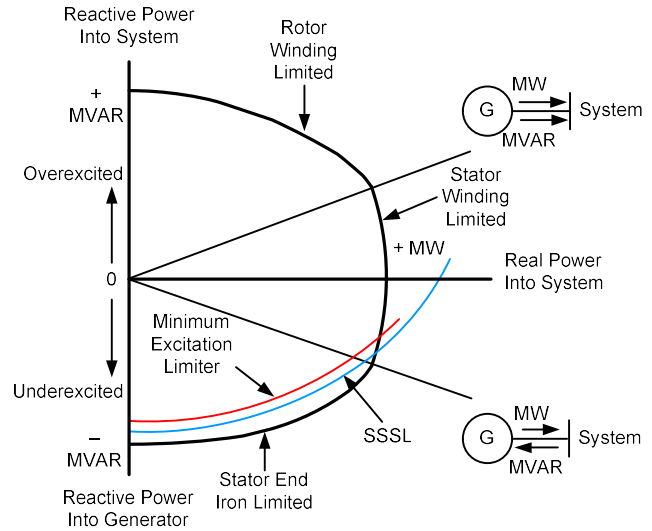

Fig. 1. Generator Capability Curve

Complete loss of excitation occurs when the direct current source connected to the generator field is interrupted. Loss of excitation can be caused by such incidents as field open circuit, field short circuit (flashover across the slip rings), accidental tripping of the field breaker, voltage regulator control system failure, loss of field to the main exciter, and loss of an ac supply to the excitation system.

When a synchronous generator loses its excitation, it runs at higher than synchronous speed and operates as an induction generator delivering real power (MW) to the system. At the same time, the generator obtains its excitation from the system in the form of vars and becomes a large reactive drain on the system. This large reactive drain causes problems for the generator, adjacent machines, and the power system. The system impact of loss of field to a generator depends on the stiffness of the connected system, load on the generator prior to the loss of field, and the size of the generator.

II. GENERATOR DAMAGE

When a combustion gas or steam turbine generator experiences a loss of field, it operates as an induction generator causing the temperature of the rotor surface to increase because of eddy currents in the field winding, rotor body, wedges, and retaining rings. Dangerous overheating may occur, particularly at the ends of the rotor where currents flow across the slots through the wedges and the retaining rings. The high reactive current drawn by the generator from the system can overload the stator winding, causing the stator temperature to increase. Machine damage can occur in as few as 10 seconds to several minutes. The time depends on the

machine, type of excitation loss, governor characteristics, and generator load.

Because of saliency, a hydroelectric generator may carry 20 to 25 percent of normal load without a field and maintain synchronism. The actual load carrying capability is a function of machine and system characteristics. Also, operation with nearly zero field and at reduced load is often necessary to accept line charging current. However, if a loss of field occurs when a hydroelectric generator is carrying full load, it will behave and produce the same effects as a steam turbine driven generator. High stator and induced field currents may damage the stator winding, the field windings, and/or the amortisseur windings while the unit causes a var drain on the system.

III. SYSTEM EFFECTS OF A LOSS-OF-FIELD CONDITION

A loss-of-field condition that is not detected quickly can have a devastating impact on the power system by causing a loss of reactive support and creating a substantial reactive power drain for a single event. This condition can trigger an area-wide voltage collapse if a sufficient source of reactive power is not available to meet the demand for vars created by the loss-of-field condition. If the generator that has sustained a loss of field is not isolated, transmission lines can trip because of power swings or excessive reactive power flow to the faulty generator.

IV. GENERATOR LOSS-OF-FIELD CHARACTERISTICS

When a generator loses its excitation while operating at various levels of loading, the variation of impedance as viewed at the machine terminals will have the characteristics shown on the R-X diagram in Fig. 2.

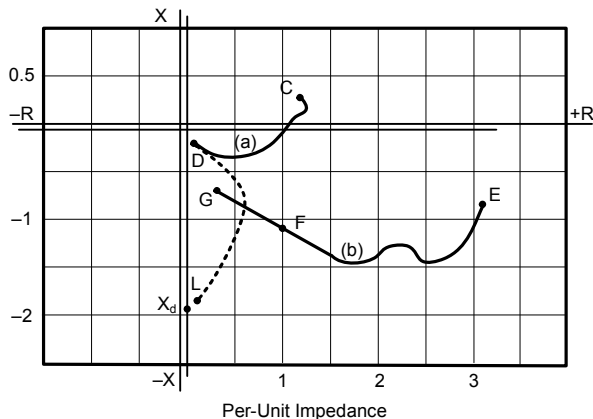

Fig. 2. Loss-of-Field Characteristic of a Generator

Curve (a) shows the impedance variation with the machine operating initially at or near full load. The initial load point is at C, and the impedance locus follows the path from C to D. The impedance locus terminates at D to the right of the $(-x)$ ordinate and approaches impedance values somewhat higher than the average of the direct and quadrature-axis subtransient generator impedances.

Curve (b) illustrates a machine that initially operates at 30 percent load and underexcited. In this case, the impedance locus follows the path from E to F to G and oscillates in the region between F and G. For a loss of field at no load, the impedance as viewed from the machine terminals varies between the direct and quadrature-axis synchronous reactances (X_d , X_q). Generally for any machine loading, the impedance viewed from the machine terminals terminates on or varies about the dashed curve from D to L.

The impedance trajectory locus depends on the value of system impedance. Machines connected with system impedances approximately less than 20 percent take a direct path to the final point, and with higher system impedances, the trajectory spirals into the final point. The spiral path is faster than the direct path.

If the machine is fully loaded prior to the loss-of-excitation condition, the machine at the final impedance point will operate as an induction generator, with a slip of 2 to 5 percent above normal. The machine will also start receiving reactive power from the system while supplying reduced real power. High system impedance results in low power output and high slip.

V. PROTECTION

The loss-of-field protective relay should reliably detect the loss-of-excitation condition without responding to load swings, system faults, and other transients that do not cause machine instability. Presently available loss-of-excitation relays provide reliable protection. The potential for misoperation of these relays from system disturbances is low when properly set.

A. Protection Schemes Based on Field Current

Protection schemes based on the measurement of machine field current with overcurrent and undercurrent relays can detect generator loss of excitation. However, this scheme is not reliable during all system conditions. Measurement of reactive current through the generator (or reactive power) has also been used to detect loss-of-excitation conditions. This scheme provides good loss-of-field protection and has low cost, but it does not differentiate well between a loss-of-field and other system fault conditions. These schemes are typically applied on small generators.

B. Negative Offset Mho Element Protection Schemes

The most popular and reliable protection scheme for loss-of-field detection uses an offset mho relay. Fig. 3 shows the operating characteristic of a single zone offset mho relay.

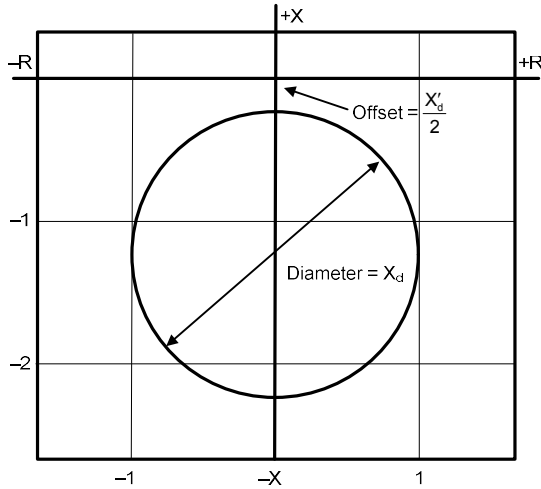

Fig. 3. Single Zone Offset Mho Relay Characteristic

Connected at the machine terminals and supplied with terminal voltages and currents, this relay measures the impedance as viewed from the machine terminals and operates when the impedance falls inside the circular characteristic.

The relay is offset from the origin by one-half of the direct axis transient reactance $X'_d/2$ to prevent misoperation during system disturbances and other fault conditions. The diameter of the circle is adjusted to equal the direct axis synchronous reactance. A time delay of 0.5 to 0.6 seconds provides security against stable power swings. These settings can provide loss-of-excitation protection of the generator from no load to full load provided that the generator direct axis synchronous reactance ranges from 1.0 to 1.2 pu.

Note that the minimum excitation limiter (MEL) and the loss-of-field characteristic should be coordinated so that their characteristics do not overlap (see Fig. 4). The MEL prevents leading var excursions into the loss-of-field characteristic to avoid relay misoperation for system transients.

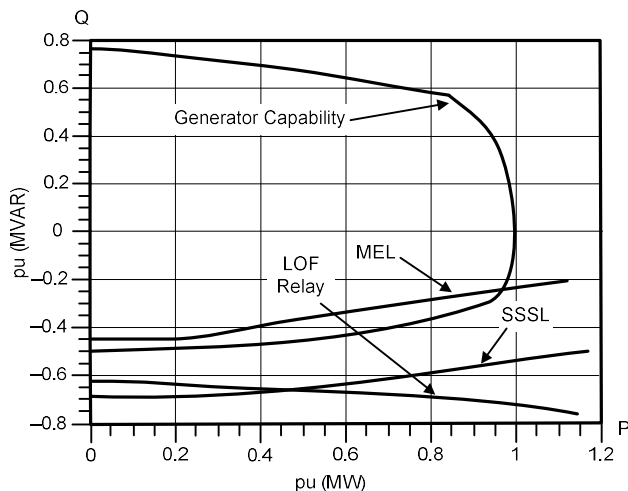

Fig. 4. Coordination of Loss-of-Field (LOF) Relay with MEL

Modern machines that are designed with higher synchronous reactance range from 1.5 to 2.0 pu. With these high synchronous reactances, setting the diameter of the offset mho relay to X_d opens up the possibility of relay misoperation during underexcited operation and stable power swings. To prevent these misoperations, the circle diameter is limited to 1.0 pu (on the generator base) instead of X_d . This reduced setting limits the protection coverage to heavily loaded machine conditions and does not provide protection for light load conditions.

To circumvent this limitation, two offset mho relays can be used, as shown in Fig. 5. The relay with 1.0 pu (on the generator base) impedance diameter detects a loss-of-field condition from full load to about 30 percent load. The relay is set with a short time delay (0.1 second delay is suggested for security against misoperation during transients) to provide fast protection for severe conditions in terms of possible machine damage and adverse effects on the system. The second relay, with a diameter equal to X_d and a time delay of 0.5 to 0.6 seconds, provides protection for a loss-of-excitation condition up to no load. The two offset mho relays provide loss-of-excitation protection for any loading level. Both relays are set with an offset of $X'_d/2$. Fig. 5 depicts this approach. Experience has shown that these Zone 1 and Zone 2 settings are secure from stable swing encroachments over a wide range of system conditions. However, transient stability analysis should be performed to verify this.

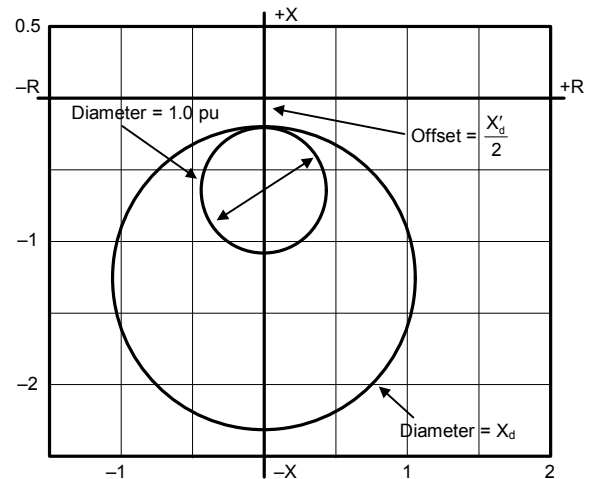

Fig. 5. Two Zone Offset Mho Relay Characteristic

C. Positive Offset Mho Element Protection Schemes

Examination of Fig. 4 shows that the negative offset mho element characteristic leaves an underprotected area relative to the SSSL and the stator end iron limit curve of the machine capability. To improve coverage for underexcited operation, the scheme illustrated in Fig. 6 can be used. This scheme uses a combination of a positive offset mho relay, a directional relay, and an undervoltage relay applied at the generator terminals and set to look into the machine. The directional unit supervises the mho unit because the positive offset will allow it to operate for faults external to the terminals of the generator.

The mho unit (shown as Z2 on Fig. 6) is set to coordinate with the generator minimum excitation limiter (MEL), the generator underexcited capability curve, and the SSSL. The Z2 positive offset, X_s , is the impedance of the system beyond the machine terminals. A conservative approach calculates the system equivalent impedance under an N-1 condition. The diameter of the SSSL circle is given by $X_s + X_d$, so the recommended setting of 1.1 for reach into the machine shown in Fig. 6 provides a margin from the SSSL.

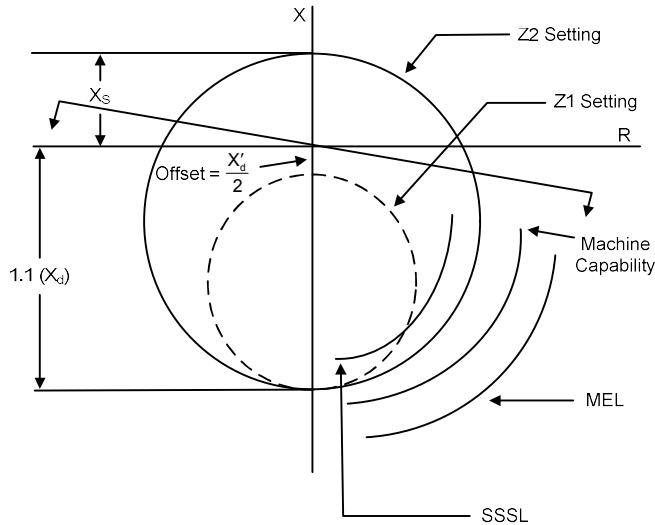

Fig. 6. Loss-of-Field Protection Using Impedance Relay and Directional Element

A well-coordinated scheme is illustrated in Fig. 6. The MEL is set outside the machine capability curve to prevent operation in the stator end iron damage region of the machine capability curve, as well as the SSSL, to reduce the possibility of going out of step. The loss-of-field characteristic is set between the machine capability curve and the SSSL. In weaker systems with high transfer impedance, the SSSL may encroach on the machine capability curve. An example of this is shown in Fig. 1. In that case, the loss-of-field characteristic should be set outside the machine capability curve (inside on the PQ diagram) between the SSSL and the MEL.

During abnormally low excitation conditions, such as might occur following a failure of the MEL, these relays operate and provide an alarm, allowing a station operator to correct the condition. When a low-voltage condition also exists, indicating a loss-of-field condition, the undervoltage relay operates and initiates tripping with a time delay of 0.25 to 1.0 seconds. The shorter time is used if there is no Zone 1 element.

Two relays may also be used in this scheme, with the second (shown as Z1 in Fig. 6) set with an offset equal to $X'_d/2$ and with the long-reach intercept equal to 1.1 times X_d . In this case, the relay with the Z1 setting trips with a time delay of 0.2 to 0.3 seconds to ride through stable swings and system transients. It is advisable to conduct system studies to determine the time delay.

D. Hydroelectric Application Considerations

When applying this protection to hydroelectric generators, other factors may have to be considered. Because hydroelectric generators may operate occasionally as synchronous condensers, it is possible for the previously described loss-of-field relaying schemes to operate unnecessarily when the generator is underexcited, that is, taking in vars approaching machine rating. To prevent unnecessary operations, an undervoltage relay is used to supervise the distance relaying schemes. The dropout level of this undervoltage relay is set at 90 to 95 percent of rated voltage, and the relay is connected to block tripping when picked up and permit tripping when dropped out. This combination provides protection for almost all loss-of-field conditions but may not trip when the generator is operating at light load because the voltage reduction may not be sufficient to cause relay drop out.

A system stability study may be required to evaluate the generator and system response to power system faults. The response of the loss-of-field relays under these conditions must be studied to see if they respond to power swing conditions as a result of system faults. The transmission owner, generator owner, and planning coordinator must share information on these studies and loss-of-field relay settings to prevent inadvertent tripping of generators for external fault conditions not related to a loss-of-field condition.

VI. TRIPPING MODE

The loss-of-field protection is normally connected to trip the main generator breaker(s), the field breaker and transfer unit auxiliaries. The field breaker is tripped to minimize rotor field damage when a loss of field is caused by a rotor field short circuit or a slip ring flashover. With this approach, if the loss of field was caused by an easily remedied condition, a tandem compound generator could be quickly resynchronized to the system. This approach may not be applicable with once-through boilers, cross-compound units, or those units that cannot transfer sufficient auxiliary loads to maintain the boiler and fuel systems. In these cases, the turbine stop valves are also tripped.

VII. REFERENCE

- [1] *IEEE Guide for AC Generator Protection*, IEEE Standard C37.102-2006.

Current Unbalance (Negative-Sequence) Protection

Kevin Stephan and Murty V. V. S. Yalla

Abstract—A number of system conditions can cause unbalanced three-phase currents in a generator. These system conditions produce negative-sequence components of current that induce a double-frequency current in the surface of the rotor. Rotor currents that exceed the generator negative-sequence capability can cause high and dangerous temperatures in a very short time. Common practice provides protection for the generator for external unbalanced conditions that might damage the machine. This protection consists of a time-overcurrent relay that is responsive to negative-sequence current. Negative-sequence time-overcurrent relays are available with characteristics that match the negative-sequence current capabilities of the generator.

I. INTRODUCTION

Negative-sequence relaying protects generators from excessive heating in the rotor resulting from unbalanced stator currents. From symmetrical component representation of unbalanced system conditions, currents in the generator stator can be broken down into positive-, negative-, and zero-sequence components. By definition, the magnetic field component created by the negative-sequence current rotates in the opposite direction of the power system and rotor. Thus, the negative-sequence component of the unbalanced currents induces a double-frequency surface current in the rotor that flows through the retaining rings, slot wedges, and to a smaller degree in the field winding. Rotor currents that exceed the negative-sequence capability of the generator can cause dangerously high temperatures in a very short time.

There are a number of sources of unbalanced three-phase currents to a generator. The most common causes are system asymmetries (single-phase step-up transformers with different impedances or untransposed transmission lines), unbalanced loads, unbalanced system faults, and open circuits. The highest source of negative-sequence current is the generator phase-to-phase fault. Note that on generators with step-up transformers with delta-wye connections, a system phase-to-ground fault on the wye side of the step-up transformer is seen by the generator as a phase-to-phase fault. The generator phase-to-ground fault does not create as much negative-sequence current for the same conditions as the phase-to-phase fault. The open conductor condition produces low levels of negative-sequence current relative to the levels produced by phase-to-phase or phase-to-ground faults [1]. If undetected, the open conductor condition poses a serious threat to the generator since the negative-sequence current will produce excessive rotor heating, even at low levels of load current.

II. NEGATIVE-SEQUENCE GENERATOR DAMAGE

For balanced system conditions with only positive-sequence current flowing, an air-gap flux rotates in the same direction and in synchronism with the field winding on the rotor. During unbalanced conditions, negative-sequence current is produced. The negative-sequence current component produces flux that rotates in the opposite direction from the rotor. The flux produced by this current as seen by the rotor has a frequency of twice the synchronous speed as a result of the reverse rotation combined with the positive rotation of the rotor.

The skin effect of twice the frequency of the rotor current forces the current into the surface elements of the rotor.

Fig. 1 outlines the general form of a cylindrical rotor. The coils are fastened to the rotor body by metal wedges that are forced into grooves in the rotor teeth. The ends of the coils are supported against centrifugal force by steel retaining rings that are shrink-fitted around the rotor body. Skin effect causes the double-frequency currents to concentrate at the surface of the pole faces, teeth, and rotor body for a cylindrical-rotor machine. The rotor wedges and the metallic strips below the wedges located near the surface of the rotor conduct the high-frequency current. This current flows along the surface to the retaining rings. The current then flows across the metal-to-metal contact of the retaining rings to the rotor forging and wedges. Because of the skin effect, only a very small portion of this high-frequency current flows into the field windings.

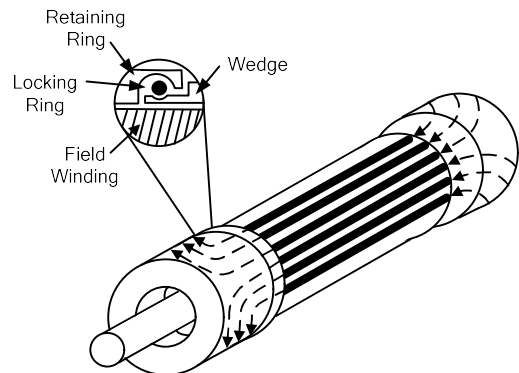

Fig. 1. Currents in the Rotor Surface

For a salient-pole machine, the double-frequency currents are also concentrated at the surface of the pole faces and teeth. Much of the current appears in the pole face amortisseur windings.

In cylindrical rotors, negative-sequence heating beyond rotor limits results in two failure modes. First, the wedges are overheated to the point where they anneal enough to rupture. Second, the heating can cause the retaining rings to expand and float free of the rotor body, which results in arcing at the shrink-fit joints. In smaller machines, the failure of the shrink-fit joints occurs first and, in larger machines, the rupture of the wedges after they have been annealed from overheating occurs first. Both failure modes will result in significant equipment downtime for repairs to the rotor body.

III. NEGATIVE-SEQUENCE GENERATOR HEATING

Negative-sequence heating in synchronous generators is a well-defined process that produces specific limits for unbalanced operation. Except for a small heat loss in the stator, the losses due to the negative-sequence current appear in the machine rotor. The energy input to the rotor and the rotor temperature rise over an interval of time and are closely proportional to $I_2^2 t$, where I_2 is the negative-sequence current from the stator and t is the interval of time in seconds.

The following rating method was developed based on limiting the temperature to the rotor components below the damage level. This limit is based on the following equation for a given generator:

$$K = I_2^2 t$$

K = constant depending on generator design and size

t = time in seconds

I_2 = rms value of negative-sequence current in pu

The limiting K value is determined by placing temperature sensors on the rotor along the negative-sequence current path while negative-sequence current is supplied to the stator. This monitoring determines the limiting negative-sequence currents that the rotor can withstand. The K value is provided by the generator manufacturer for each specific unit in accordance with machine design standards such as IEEE Standard C50.13 for cylindrical-rotor machines and IEEE Standard C50.12 for salient-pole machines [2] [3].

IV. GENERATOR NEGATIVE-SEQUENCE CAPABILITY

The continuous unbalance current capability of a generator, as defined in [2] and [3], requires that a generator shall be capable of withstanding, without injury, the effects of a continuous phase current unbalance corresponding to a negative-sequence current I_2 of the following values (see Table I), providing that the rated kVA is not exceeded and the maximum current does not exceed 105 percent of rated current in any phase.

These values also express the negative phase-sequence current capability at reduced generator kVA capabilities as a percentage of the stator current corresponding to the reduced capability.

TABLE I
CONTINUOUS UNBALANCE CURRENT CAPABILITY

Generator Type	Permissible I_2 Stator Rating Percent
Salient Pole	
With Connected Amortisseur Windings	10
With Nonconnected Amortisseur Winding	5
Cylindrical Rotor	
Indirectly Cooled	10
Directly Cooled	
To 350 MVA	8
351–1250 MVA	$8 - [(MVA-350)/300]$
1251–1600 MVA	5

The short-time (unbalanced fault) negative-sequence capability of a generator is also defined in [2] and [3] and shown in Table II. Short-time values apply for 120 seconds or less. Beyond 120 seconds, the continuous capability should be used.

TABLE II
SHORT-TIME UNBALANCE CURRENT CAPABILITY

Generator Type	K Permissible $I_2^2 t$ (I_2 in pu)
Salient-Pole Generator	40
Synchronous Condenser	30
Cylindrical-Rotor Generator	
Indirectly Cooled	30
Directly Cooled	
0–800 MVA	10
801–1600 MVA	See Fig. 2

The short-time values in Table II and Fig. 2 also express the negative-sequence current capability at reduced generator kVA capabilities using per-unit stator current corresponding to the reduced capability.

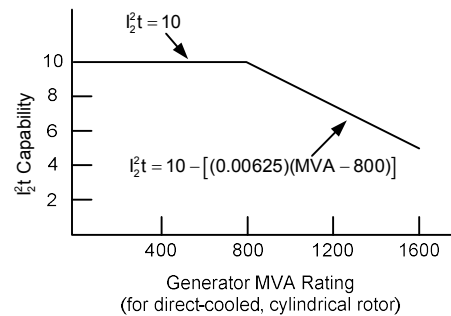

Fig. 2. Short-Time Unbalance Current Capability of Generators for a Direct-Cooled Cylindrical Rotor

The values expressed in Table I and Table II apply to generators manufactured in the year 2005 and later. Values for generators built prior to 2005 should be obtained by consulting the manufacturer or referring to older standard values in effect at the time the generator was manufactured.

V. NEGATIVE-SEQUENCE RELAY CHARACTERISTICS

With the unbalance current capabilities of the generator defined by the negative-sequence current as measured at the stator, a negative-sequence time-overcurrent relay can be used to protect the generator. These relays consist of a negative-sequence segregating network supplied by the phase and/or residual components that drives a time-overcurrent relay function. The time-overcurrent characteristics are designed to match as closely as possible the generator $I_2^2 t$ characteristics. Fig. 3 shows a typical negative-sequence relay application.

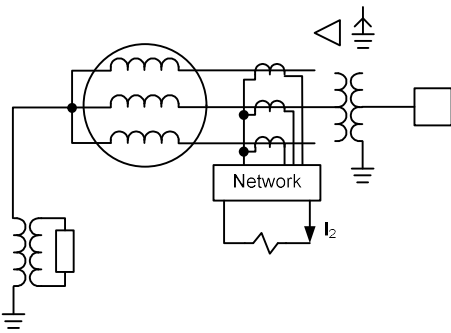

Fig. 3. Typical Negative-Sequence Time-Overcurrent Relay Application

Two types of relays are widely used: an electromechanical relay that uses a typical inverse-time characteristic and a static or digital relay that uses a characteristic that matches the $I_2^2 t$ capability curve of the generator. Fig. 4 and Fig. 5 show the typical characteristics of these relays [4]. Digital relays often do not include a maximum timing limit of 990 seconds as shown in Fig. 5.

Sensitivity is the main difference between these two types of relays. The electromechanical relay can be set to pick up at around 0.6 to 0.7 pu of full load current. The static or digital relay has a pickup range of 0.03 to 0.2. As an example, for an 800 MVA directly cooled generator with a K factor of 10, the generator could handle 0.6 pu negative-sequence current for approximately 28 seconds. Protection for negative-sequence currents below 0.6 pu would not be detected with an electromechanical relay. Given the low values of negative sequence for open-circuit unbalances as well as low-value, long-clearing faults, the static or digital relay is much better for providing coverage down to the continuous negative-sequence capability of the generator.

Since the operator can in many cases reduce negative-sequence current caused by unbalanced conditions (such as by reducing generator load), it is advantageous to provide indication when the continuous negative-sequence capability of the machine is exceeded. Some relays have alarm units (I_2 pickup range 0.03–0.2), and digital relays provide an I_2 meter to indicate the negative-sequence current level.

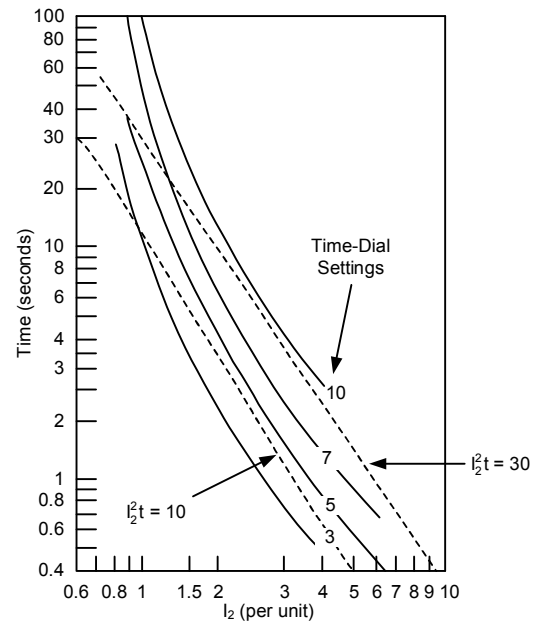

Fig. 4. Typical Time-Overcurrent Curves for an Electromechanical Negative-Sequence Relay

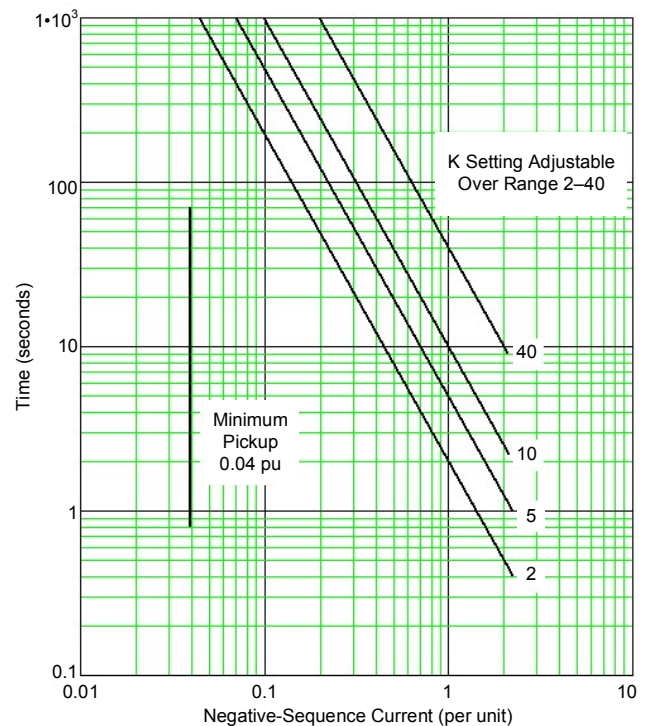

Fig. 5. Characteristics of a Static or Digital Negative-Sequence Time-Overcurrent Relay

Protection against negative-sequence harmonics from such sources as the saturation of a unit step-up transformer (from geomagnetic currents) or nonlinear system loads is not provided by standard negative-sequence relaying [5] [6]. Additional protection may be required to provide protection for negative-sequence harmonics because of the frequency dependence of negative-sequence relays.

VI. NEGATIVE-SEQUENCE PROTECTIVE SCHEMES

Dedicated negative-sequence relays are usually provided for generator protection. In general, backup relaying for negative-sequence is not provided. Some limited protection is provided by the phase-to-phase and phase-to-ground protection for fault conditions. For open conductor or impedance unbalance protection, the negative-sequence relay is usually the only protection. The magnitude of negative-sequence currents created by open conductor conditions and low-magnitude faults combined with the generator continuous negative-sequence ratings prevent other fault relays from providing full negative-sequence protection.

For electromechanical relays, the minimum negative-sequence current pickup can only be set around 60 percent of rated current. This provides only limited protection for series unbalance conditions such as an open phase when the electromechanical relay is used.

Static or digital relays have the capability of being set to protect generators with K values of 10 or less. An alarm setting associated with these relays provides detection for negative-sequence current down to 3 percent of machine rating. With this type of relay, the trip pickup can be set at the continuous negative-sequence capability of the generator operating at full output and provide full unbalance protection.

VII. TRIPPING MODE

The negative-sequence relay is often connected to trip just the main generator breaker(s) if the machine auxiliaries allow such operation. This mode allows rapid reconnection to the power system if the cause of excessive negative-sequence can be removed quickly. If the unit auxiliaries do not allow

continued operation when separated from the power system, the negative-sequence relay should also trip the machine prime mover and the field breaker and should transfer the auxiliaries to a reserve or standby source.

VIII. CONCLUSIONS

Dedicated protection needs to be applied to generators to protect against destructive heating from negative-sequence unbalance currents. Electromechanical negative-sequence relaying will provide only limited protection. These relays lack the sensitivity to detect damaging negative-sequence currents resulting from open circuit unbalances as well as low-level faults. To provide full protection down to the continuous rating of the generator, static or digital negative-sequence relays must be used.

IX. REFERENCES

- [1] D. J. Graham, P. G. Brown, and R. L. Winchester, "Generator Protection With a New Static Negative Sequence Relay," *IEEE Transactions on Power Apparatus and Systems*, vol. 94, issue 4, pp. 1208-1213, Jul. 1975.
- [2] *IEEE Standard for Salient-Pole 50 Hz and 60 Hz Synchronous Generators and Generator/Motors for Hydraulic Turbine Applications Rated 5 MVA and Above*, IEEE Standard C50.12-2005.
- [3] *IEEE Standard for Cylindrical-Rotor 50 Hz and 60 Hz Synchronous Generators Rotor 10 MVA and Above*, IEEE Standard C50.13-2005.
- [4] *IEEE Guide for AC Generator Protection*, IEEE Standard C37.102-2006.
- [5] W. B. Gish, W. E. Feero, and G. D. Rockefeller, "Rotor Heating Effects From Geomagnetic Induced Currents," *IEEE Transactions on Power Delivery*, vol. 9, issue 2, pp. 712-719, Apr. 1994.
- [6] B. Bozoki, "Protective Relaying Implication of Geomagnetic Disturbances," Canadian Electrical Association, Power System Planning & Operations, May 1991.

Loss of Prime Mover (Antimotoring) Protection

Dale Finney and Gerald Johnson

Abstract—Motoring is an example of abnormal operation that can quickly damage a machine. As a consequence, IEEE guides recommend quick detection of this condition to isolate the generator from the system.

I. MOTORING

Motoring occurs when the energy supply to the prime mover is cut off while the generator is still online. When this occurs, the machine will behave as a synchronous motor, drawing enough power from the system to overcome the losses of the generator and prime mover. The chief concern associated with motoring is the potential for damage to the prime mover.

The type and severity of damage vary with machine type. In steam turbines, a loss of steam flow disrupts normal heat transfer, resulting in increased thermal stress in various parts of the turbine. Gas turbines may suffer gear damage when driven from the generator end. In hydroelectric turbines, blade cavitation on low water flow can occur during a motoring event. Motoring of a reciprocating engine could result in an explosion of unburned fuel [1].

II. DETECTION METHODS

Various methods are used to detect a loss of prime mover, depending again on the machine type. For instance, a steam turbine may employ a temperature sensor in the exhaust hood to detect temperature buildup resulting from a loss of steam flow. Measurement of pressure differential across the high-pressure turbine element also indicates motoring [1]. However, the most generally applied method is electrical measurement of real power flow into the machine terminals. The element responsible for this measurement is the reverse-power relay (IEEE Device Number 32).

III. APPLICATION CONSIDERATIONS

A. Pickup Setting

Depending on the machine, the motoring losses of a turbine generator can be very low when expressed as a percentage of the machine rating. This can require a very sensitive reverse-power measurement. Table I lists typical values for various machine types. The generator manufacturer data sheet and relay manufacturer guidelines should be used to derive the pickup setting.

TABLE I
MOTORING POWER

Machine Type	Motoring Power (Percentage of Rating)
Combustion Gas Turbine	< 50%
Diesel	< 25%
Steam	0.5–3%
Hydroelectric	0.2–2%

A reverse-power element cannot detect a motoring event under some operating conditions. For instance, if the excitation system maintains a significant reactive power output during a loss of prime mover, the ratio between real and reactive power can be low. Some reverse-power relays may not accurately measure very low power levels at low power factors. If the reactive power cannot be reduced during such an event, use an alternate detection method as discussed in Section II.

B. Time Delay

The reverse-power element is always applied with a time delay. A machine can operate in a motoring condition for a maximum permissible time. This value should be obtained from the generator data sheets or by consulting with the generator manufacturer. The element's time delay must be set lower than this value. However, a transient reverse-power condition can occur during a stable power swing or poor synchronization. The time delay must be set long enough to prevent operation for these events. Given the extremely sensitive setting required for a steam turbine, a delay of 30 seconds is typical. Other prime movers such as reciprocating engines, which have a higher motoring power setting and a risk of fire or explosion if allowed to motor too long, may use a lower time delay. On such applications the reverse power relay may have a typical pickup setting of 10% with a time delay of 6 to 10 seconds.

C. Intentional Motoring

Motoring of certain machines is permitted during normal operation. These situations include some gas turbines started as synchronous motors connected to load-commutated inverter (LCI) starters and in pumped storage applications where the machine is alternately operated as a generator or motor. When operated as synchronous condensers, hydroelectric units will motor. Reverse-power element application must be inhibited during intentional motoring operation. This is accomplished by dynamically blocking the element or by disabling the element through a settings group change.

D. Tripping Mode

The reverse-power relay generally initiates a simultaneous trip. This entails disconnecting the generator from the power system, shutting down the excitation, initiating an auxiliary bus transfer, and shutting down the prime mover.

E. Sequential Tripping

If a machine is disconnected from the system while under load, the mismatch between electrical and mechanical power will result in a speed increase. The severity of the overspeed is a function of loading and machine type. Some machines, such as steam turbines, are particularly sensitive to an overspeed event. For these machines, disconnection from the system is delayed to include a period of deliberate motoring to ensure that overspeed cannot occur. This method is known as sequential tripping. A reverse-power element indicates that the machine is motoring. Fig. 1 shows an example of sequential tripping logic. In this example, 32-1 is the reverse-power element for motoring detection, and 32-2 is the element for sequential tripping. Typical time settings for steam units are 30 seconds for 32-1 and 3 seconds for 32-2.

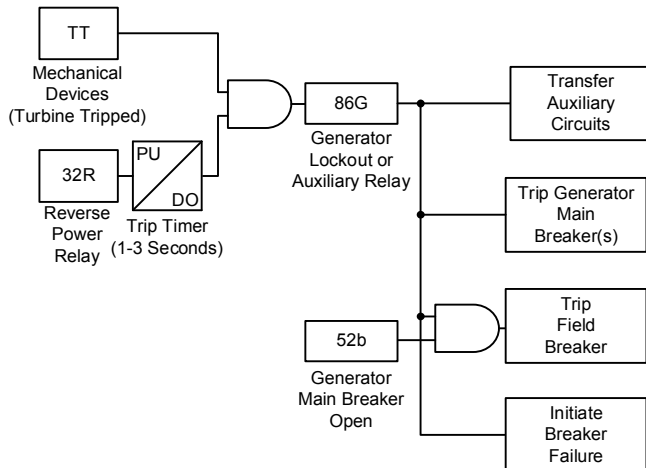

Fig. 1. Sequential Tripping Logic Example [1]

For increased security against possible overspeed, steam turbine manufacturers recommend that the sequential tripping circuit have a mechanical confirmation of steam flow cutoff in series with the reverse-power relay. Typically, this mechanical confirmation uses either steam valve closed-position switches or the contact from a differential pressure switch connected across the high-pressure turbine [2].

F. Application of Settings

The pickup criteria are the same as those given in Section III, Subsection A.

IV. REFERENCES

- [1] *IEEE Guide for AC Generator Protection*, IEEE Standard C37.102-2006.
- [2] E. Fennell, K. Kozminski, M. Bajpai, S. Easterday-McPadden, W. Elmore, C. Fromen, J. Gardell, W. Hartmann, J. Hurley, P. Kerrigan, K. Khunkhun, C. Mozina, G. Nail, S. Patel, G. Pence, A. Pierce, D. Smaha, S. Usman, P. Waudby, and M. Yalla, "Sequential Tripping of Steam Turbine Generators," *IEEE Transactions on Power Delivery*, vol. 14, issue 1, pp. 132–141, Jan. 1999.

Out-of-Step Protection

Juan Gers and Michael Thompson

Abstract—Many combinations of operating conditions, faults, and other disturbances can cause an out-of-step condition between two parts of a power system or between two interconnected systems. If such an event occurs, the asynchronous generators should be tripped as soon as possible to prevent generator damage or avoid a widespread outage. This section of the tutorial discusses the need for out-of-step generator protection, reviews basic transient stability concepts, describes the out-of-step impedance characteristics typical of large generators connected to high-voltage transmission systems, and presents various relaying schemes that are used for generator out-of-step protection. A thorough procedure to determine the settings is proposed and illustrated with a case study, which includes transient stability simulation cases and out-of-step relay performance testing using COMTRADE (Common Format for Transient Data Exchange) files.

I. INTRODUCTION

Electrical power systems are exposed to a variety of abnormal operating conditions such as faults, generator loss, line tripping, and other disturbances that can result in power oscillations and consequent system instability. Under these conditions, appropriate relay settings are essential to ensure proper protection (i.e., the disconnection of generators that lose synchronism and the blocking of undesired operation of distance relays associated with HV [high-voltage] lines). This topic has received special attention since the blackout of August 14, 2003, that severely affected millions of electrical system users in the Midwest and Northeastern United States. During this event, many relay schemes did not perform appropriately.

Transient stability studies help to determine if a system will remain in synchronism following major disturbances. The nature of these problems requires the solution of nonlinear differential and algebraic equations by direct methods or by iterative, step-by-step procedures.

Usually, the time period under study is within the first second following a system fault. If the machines connected to the system remain in synchronism within the first second, the system is considered stable. In contrast, for multiswing stability problems, the effects must be considered over an extended time period. Thus, sophisticated models must be used to accurately reflect machine behavior.

During the past several decades, system performance criteria have become more stringent, and improved cooling methods in generator designs have allowed larger MVA capacities for a given volume of cooling material. This trend has reduced inertia constants and raised machine reactances, especially on larger units. Also, the use of more HV and EHV (extra-high-voltage) transmission lines to transmit larger power levels over longer distances has resulted in reduced

critical clearing times required to isolate a system fault near a generating plant before the generator goes out-of-step with the power grid. Other factors in addition to prolonged fault clearing that can lead to instability are: operating generators in the underexcited region during light load periods, low system voltage, low unit excitation, excessive impedance between the unit and system, and some line-switching operations.

II. TRANSIENT STABILITY CONCEPTS REVIEW

Chapter 1 provides a basic description of generator instability. Transient stability concepts are further reviewed with a simple lossless transmission line connecting two sources corresponding to a generator at location S and an equivalent power system at location R. The active power, P , transferred from the generator into the network is expressed as:

$$P = \frac{V_S \cdot V_R}{X} \sin \delta \quad (1)$$

where:

V_S is the sending-end source voltage magnitude.

V_R is the receiving-end source voltage magnitude.

δ is the angle difference between the two sources.

X is the total reactance of the transmission line that connects the two sources.

With fixed V_S , V_R , and X values, the relationship between P and δ is described in the power angle curve shown in Fig. 1. Starting from δ equal to 0, the power transferred increases as δ increases. The power transferred reaches the maximum value, P_{MAX} , when δ is equal to 90 degrees. After that point, further increases in δ result in a decrease of power transfer.

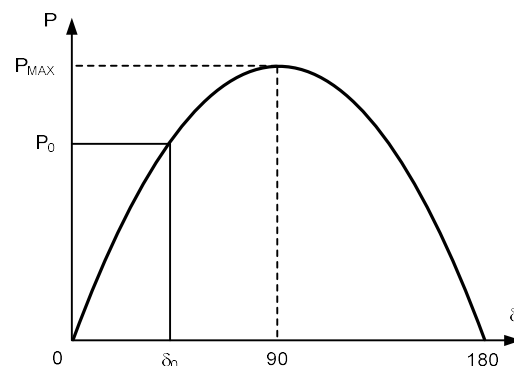

Fig. 1. Power Angle Curve

During normal conditions, the electric power output from the generator produces an electric torque that balances the mechanical torque applied to the generator rotor shaft. The rotor, therefore, runs at a constant speed with this balance of electric and mechanical torques. When a fault occurs, the

amount of power transferred is reduced, which also reduces the electric torque that counters the mechanical torque. If the mechanical power is not reduced during the fault, the generator rotor will accelerate proportionally to the net surplus of torque input.

Developments of this concept, as well as the so-called equal-area criterion, are explained in detail in most power systems books, numerous papers, and in Chapter 1.

When an unstable power system condition exists, one equivalent generator rotates at a speed different from the other equivalent generator on the system. This condition is referred to as a loss-of-synchronism or an out-of-step condition.

If such a loss of synchronism occurs, it is imperative that the generator or system areas operating asynchronously be separated immediately using out-of-step protection (IEEE device number 78). On the other hand, it is important that transmission line distance relays do not operate for system oscillations that might bring the swing locus into its protective zone coverage.

III. EFFECTS OF GENERATORS OPERATING OUT OF STEP

An out-of-step condition causes high currents and mechanical forces in the generator windings and high levels of transient shaft torques. If the slip frequency of the unit approaches a natural torsional frequency, the torques can be high enough to break the shaft. Therefore, it is desirable to immediately trip the unit because shaft torque levels build up with each subsequent slip cycle. This buildup results from continually increasing slip frequency passing through the first natural torsional frequency of the shaft system. Pole slipping events can also result in abnormally high stator core end iron fluxes that can lead to overheating and shorting at the stator core ends. The unit step-up transformer will also be subjected to very high transient winding currents that impose high mechanical stresses on the windings.

IV. OUT-OF-STEP CHARACTERISTICS

The best way to visualize and detect out-of-step phenomena is to analyze apparent impedance variations with time as viewed at the generator terminals or HV terminals of the unit step-up transformer. These apparent swing loci depend on the type of governor and excitation system of the unit, along with the type of disturbance that initiated the swing. Mho distance relays can detect this impedance variation.

Fig. 2 illustrates a simple visualization of these apparent impedance variations during an out-of-step condition. Three impedance loci are plotted as a function of the ratio of the system voltages, E_A/E_B , which is assumed to remain constant during the swing. The following assumptions are required for this simplified approach:

- Generator saliency is neglected.
- Transient impedance changes caused by fault or fault clearing have subsided.
- Shunt load and capacitance effects are neglected.
- Effects of regulators and governors are neglected.
- The E_A and E_B voltages behind the equivalent impedances are sinusoidal and of fundamental frequency.

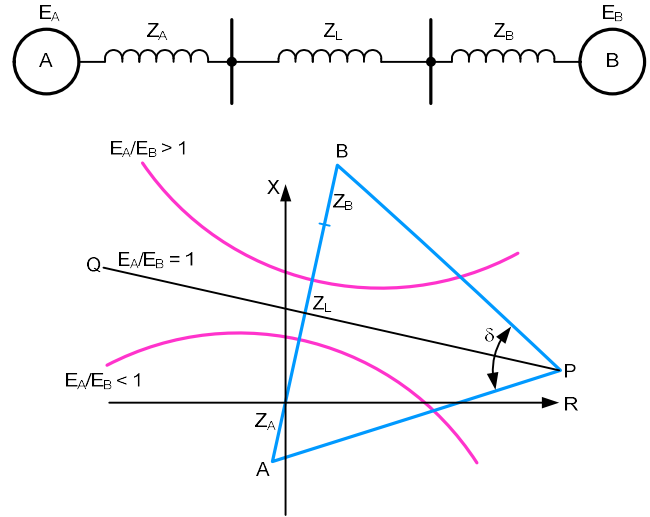

Fig. 2. Typical Out-of-Step Impedance Loci Using Simplified Graphical Procedures

When the voltage ratio E_A/E_B is equal to 1, the impedance locus is a straight line indicated by PQ, which is the perpendicular bisector of the total system impedance between A and B. The angle formed by the intersection of AP and BP on PQ is the separation angle δ between systems. As E_A advances ahead of E_B , the impedance locus moves from P toward Q and δ increases. When the locus intersects the total impedance line AB, the systems are 180 degrees out of phase.

This point when the locus intersects the total impedance line AB and the systems are 180 degrees out of phase is the electrical center of the system. The voltage approaches zero and the current is high, appearing as an apparent three-phase fault at that impedance location. As the locus moves to the left of the system impedance line, the angular separation increases beyond 180 degrees, and eventually the systems will be in phase once again. If the systems remain together, System A can continue to move ahead of System B, and the whole cycle may repeat itself. When the locus reaches the point where the swing started, one slip cycle has been completed. If System A slows down with respect to System B, the impedance locus will move in the opposite direction from Q to P.

When the voltage ratio E_A/E_B is greater than one, the electrical center will be above the impedance center of the system (PQ). When E_A/E_B is less than one, the electrical center will be below the impedance center of the system.

The electrical centers of the system vary as the system impedances behind the line terminals and the equivalent internal generator voltages vary. The rate of slip between systems depends on the accelerating torques and system inertias. Transient stability studies provide the best means to determine the slip rate and locations to where the power swing loci will go relative to the generator terminals or high-side terminals of the generator step-up transformer. Knowing the loci locations helps to determine the best relay scheme to detect an out-of-step condition.

V. GENERATOR OUT-OF-STEP CHARACTERISTICS

Before the interconnection of power systems, the electrical center during an out-of-step occurrence was in the transmission system. Thus, the impedance loci could be readily detected by line relaying or out-of-step relaying schemes. The power system could be separated without tripping generators. With the advent of HV and EHV systems, large conductor-cooled generators, fast-response voltage regulators, and the expansion of transmission systems, generator and system impedances have changed considerably. Generator and step-up transformer impedances have increased while system impedances have decreased. As a result, the system impedance center and electrical center for such situations occur in the generator or in the step-up transformer. These zones are protected by differential relaying that will not detect power swings.

If the out-of-step swing passes through the transmission lines near the generating station and the line relays are not blocked by out-of-step relaying, the lines may trip before the unit out-of-step relaying operates. Thus, the lines to the generating station could be lost.

Fig. 3 illustrates the out-of-step impedance loci of a tandem compound generator for three different system impedances. The loci were determined from a digital computer study. In these simulations, the excitation system and governor response were included, but the voltage regulator was out of service. Without the voltage regulator response, the internal machine voltages during the disturbance were low; therefore, the electrical centers of the swings were closer to the generator zone.

The instability was assumed to be caused by the prolonged clearing of a three-phase fault on the HV side of the generator step-up transformer. As Fig. 3 illustrates, the circle formed by the impedance locus increases in diameter, and the electrical center moves from within the generator into the step-up transformer as the system impedance increases. All three of these out-of-step characteristics can usually be detected by out-of-step relaying schemes discussed later.

The swing impedance trajectory of a cross-compound generator is more complex. The inertia of the high-pressure

unit is generally much smaller than the inertia of the low-pressure unit. The source impedance of the system beyond the step-up transformer will also affect whether the units tend to swing together or separately. The impedance loci will be different if observed from the terminals of each individual unit or terminals of the transformer where the current is the sum of the currents from two units. Transient stability studies can help determine which impedance loci will provide the best means of out-of-step detection.

An out-of-step condition can be detected by the loss-of-field protection or a single impedance relay whose reach encompasses the generator and step-up transformer. However, today, it is more common to use sophisticated out-of-step schemes such as the single blinder scheme, double blinder scheme, or concentric circle scheme. The concentric circle scheme is a variation on the double blinder scheme using circular impedance characteristics. These dedicated out-of-step schemes use logic and/or timers to track the impedance trajectory with respect to time to detect an unstable swing or when a generator slips a pole. The following sections describe each scheme.

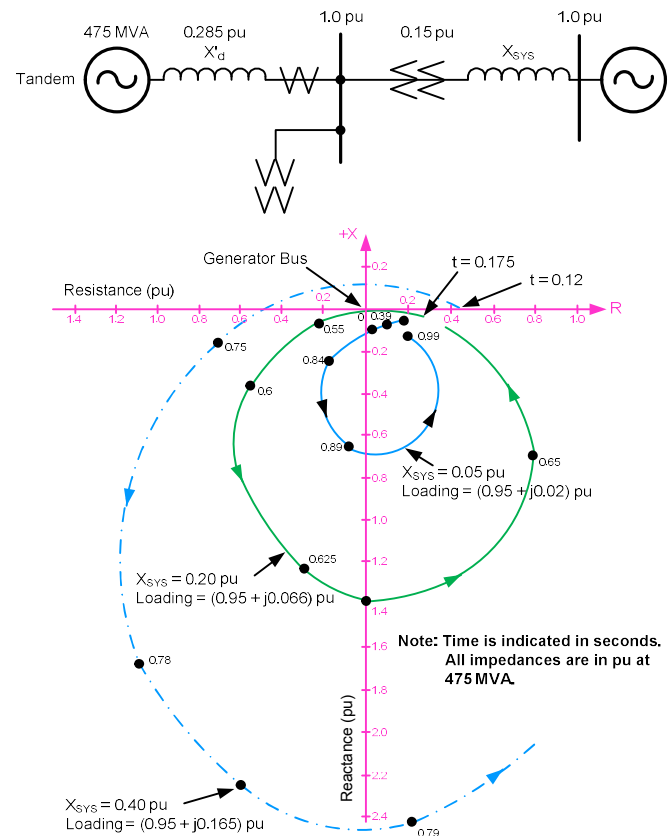

Fig. 3. Loss-of-Synchronism Characteristic of a Tandem Generator

A. Loss-of-Field Relaying

Loss-of-field relaying, as described in Chapter 3.3, is applied for protection of a generator against a loss-of-field condition. Depending on how the conventional mho distance relays are set and applied, some degree of out-of-step protection should be provided for swings that pass through the

generator. Fig. 4 illustrates a dual-mho characteristic loss-of-field protection scheme. These relays are applied to the generator terminals and set looking into the machine.

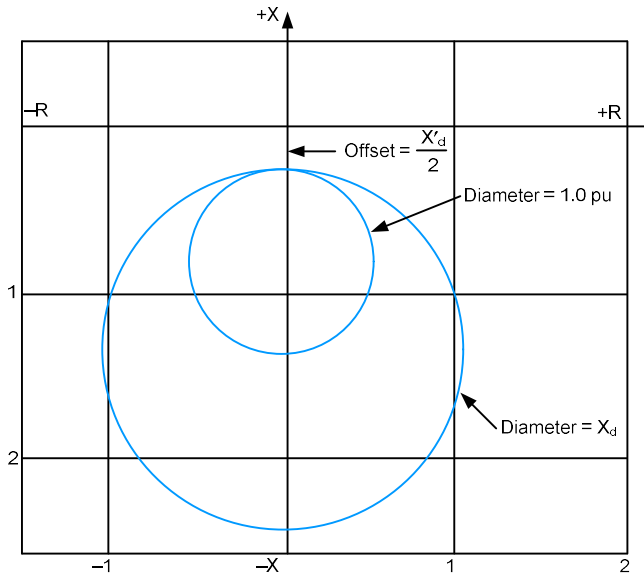

Fig. 4. Typical Loss-of-Field Relay Characteristic

The smaller mho characteristic has no intentional delay; thus, it could sense and trip an out-of-step swing that dwells inside its circle long enough. The larger mho characteristic must have a time delay to prevent misoperations on stable swings that might momentarily enter the circle; hence, it is not likely to detect an out-of-step condition because the swing will not stay inside the relay circle long enough for the timer to expire. This larger diameter characteristic, usually set to the synchronous reactance of the unit and an offset equal to one-half the transient reactance of the unit, is sometimes used by itself on small generators.

B. Single Mho Relay Scheme

A single-phase or three-phase mho distance relay can be applied on the HV terminal of the step-up transformer to look into the generator and its step-up transformer. Fig. 5 illustrates such an application where the relay detects out-of-step swings passing through the step-up transformer and overlapping the mho characteristics of the two loss-of-field relays. The advantages of this scheme are its simplicity, ability to provide backup protection for faults in the step-up transformer and in a portion of the generator, ability to detect inadvertent three-phase energizing of the unit if properly set, and the fact that tripping can occur significantly before the 180-degree point (maximum current and stress point) is reached. The disadvantages are that without supervision, a large circle is

exposed to tripping on stable swings and a small circle permits tripping of the generator breakers at high angles approaching 180 degrees, subjecting the breakers to a maximum recovery voltage during interruption.

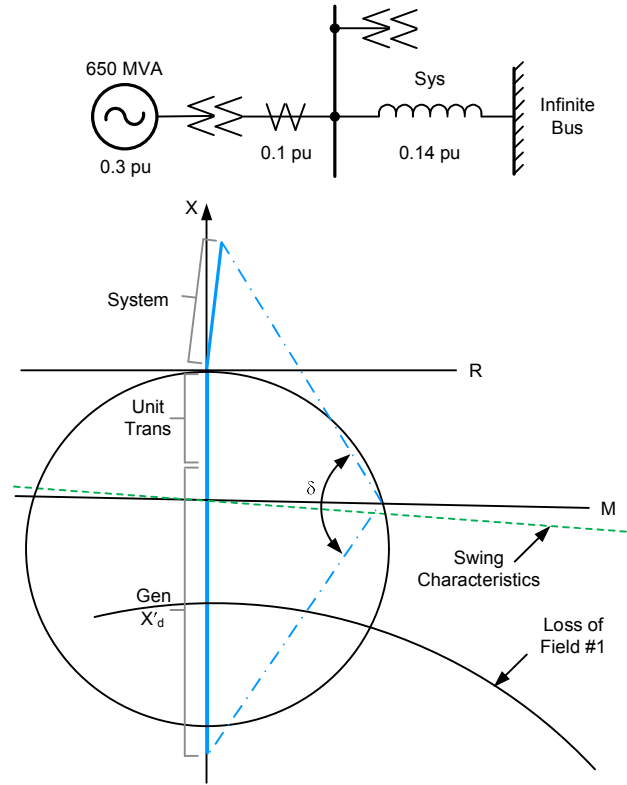

Fig. 5. Application of Mho Circle Scheme

A single mho out-of-step relay scheme can also be applied on the generator terminals with a reverse offset into the step-up transformer. However, to prevent misoperations for faults or swings appearing beyond the HV terminals of the transformer, the reach cannot encompass the HV terminals, or tripping must be delayed.

Fig. 5 illustrates an example of a single mho relay scheme applied at the HV terminals of a generator step-up transformer. The angle of swing, δ , is approximately 112 degrees at the point where the swing impedance comes into the mho circle characteristic. Recovery at this angle may be possible, but as the mho circle is set smaller to avoid tripping on stable swings, a less favorable tripping angle will occur.

Typical practice supervises the mho relay with a high-speed overcurrent fault detector in series with the trip path of the mho relay. This minimizes the possibility of getting a false unit breaker trip for a loss-of-potential condition.

C. Single Blinder Scheme

A single blinder scheme can be applied to the high-side terminals of the step-up transformer looking into the generator or applied to the generator terminals looking into the system. In either case, an offset from the point of measurement is used. Fig. 6 shows a single blinder scheme applied to the high-side of the generator step-up transformer. The sensing elements consist of two impedance elements called blinders that have opposite polarity and a supervisory offset mho relay. The mho supervisory relay restricts the operation area to swings that pass through or near the generator and its step-up transformer.

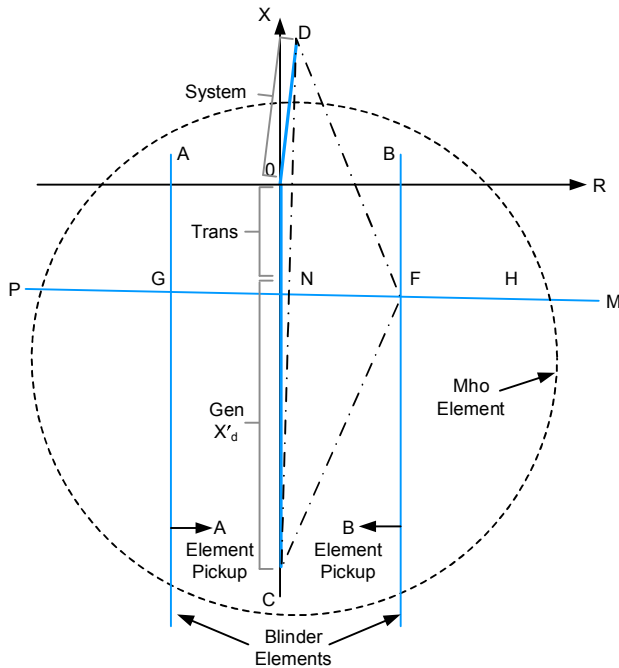

Fig. 6. Single Blinder Scheme

For the example in Fig. 6, an out-of-step swing impedance that progresses along line MP to H will pick up the mho element and cause blinder A to pick up. As the swing progresses, it will cross blinder B at F and the B element will pick up. Finally, the swing impedance will cross the A element at G and the A element will drop out. The breaker trip circuit is completed when the impedance is at G or following reset of the mho supervisory unit, depending on the specific scheme used. The reach settings of the blinders control the impedance NF and NG; hence, the angle DGC or DPC can be controlled to allow the circuit breaker to open at a more favorable angle for arc interruption. Also, depending upon the specific scheme used, the time to traverse between blinders A and B may have to be greater than a settable time to assert the trip. Faults that occur within reach of the supervisory mho element will simultaneously pick up both blinders A and B.

But, without a swing that passes through 180 degrees, tripping will not occur. Setting the single blinder scheme is easy and extremely secure. It will only operate after a pole has slipped. Therefore, it cannot misoperate on a stable swing. For these reasons, it is preferred over many of the other schemes.

The advantages of the single blinder scheme over the single mho scheme can be seen by comparing Fig. 5 and Fig. 7. As the diameter of the mho circle in Fig. 5 is increased to provide better sensitivity for out-of-step swings in the generator, undesired tripping could occur for the recoverable swing indicated in Fig. 7. However, the addition of the blinders and trajectory logic would prevent that trip. The blinder scheme will also permit tripping of the generator only when the interruption is at a favorable angle.

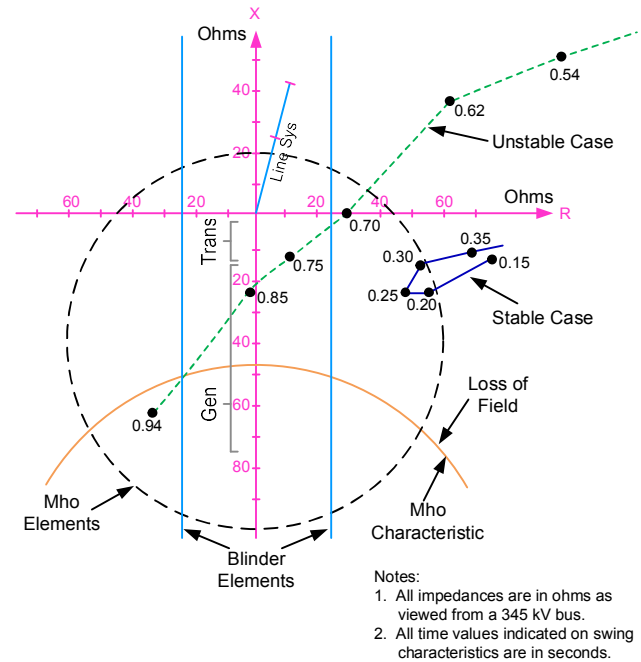

Fig. 7. Example of Single Blinder Scheme for Stable and Unstable Cases

Transient stability computer simulations are useful to determine the critical rotor angle when an unrecoverable swing occurs and the machine loses synchronism with the network. This value is used to set the blinders in a single blinder scheme. Transient stability results could be used also to verify that the time setting is appropriate. For this simulation, the most stringent condition has to be run, providing the shortest time of the swing along the path between the blinders during the out-of-step impedance excursion.

For a more realistic simulation of generator behavior, the analysis should include the appropriate modeling of the governors, voltage regulators, and power system stabilizers (if available). Where stability studies are not available, 120-degree angles are commonly used to set the blinders. At this angle, the swing is generally not recoverable. See [1] for details on how this angle was established.

D. Double Blinder Schemes

Referring to Fig. 8 and Fig. 9, the outer element operates when the swing impedance enters its characteristics at F. The mho element in the double blinder scheme will pick up before the outer blinder element. If the swing impedance stays between the outer and inner element characteristics for longer than a preset time, it is recognized as an out-of-step condition in the logic circuitry. As the swing impedance enters the inner element, the logic circuitry seals in. As the swing impedance leaves the inner element, its travel time must exceed a preset time before it reaches the outer element. Tripping does not occur until the swing impedance passes out of the outer characteristic or, in the case of the double blinder scheme, until the mho supervisory element resets, depending on the logic used.

The double blinder scheme requires the use of transient stability simulations to determine the appropriate outer and inner blinder settings and the excursion time. In this case though, care has to be exercised to ensure that the condition produces the fastest impedance traveling time. Otherwise, the time setting could risk the security of the relay operation. This makes this scheme harder to set and less secure.

Angle DFC is controlled by setting the outer elements to limit the voltage across the opening poles of the generator breaker. Once the swing has been detected and the swing impedance has entered the inner element, it can leave the inner and outer elements in any direction, and tripping will take place. Hence, the inner element setting should respond only to nonrecoverable swings. For this reason, transient stability analysis is extremely important to setting this scheme.

E. Concentric Circle Scheme

The concentric circle scheme uses two mho relays. It operates essentially the same as the double lens scheme. When the concentric circle scheme is used, the inner circle must be set to respond only to nonrecoverable swings.

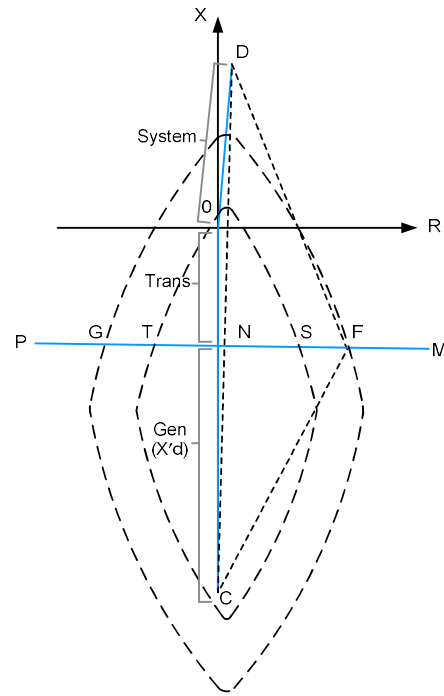

Fig. 8. Double Lens Scheme

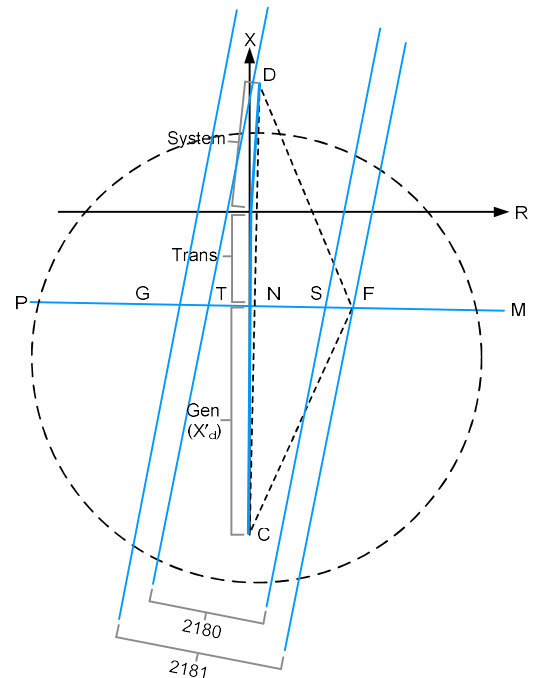

Fig. 9. Double Blinder Scheme

VI. SETTING SINGLE BLINDER OUT-OF-STEP PROTECTION ELEMENTS

Fig. 10 illustrates the impedance settings. The settings of the 78 element are carried out with the following procedure:

1. Model the overall system, and carry out transient stability simulation cases for representative operating conditions. Modeling of the generators should include the voltage regulator, generator governor, and PSS (power system stabilizer) if available. For the single blinder scheme, the data obtained from the transient stability simulation cases are helpful.
2. Determine the values of generator transient reactance (X'_d), unit transformer reactance (X_{TG}), and system impedance under maximum generation ($X_{\max SG1}$).
3. Set the mho unit to limit the reach to 1.5 times the transformer impedance in the system direction. In the generator direction, the reach is typically set at twice the generator transient reactance. Therefore, the diameter of the mho characteristic is $2X'_d + 1.5X_{TG}$.
4. Determine, by means of the transient stability simulation cases, the critical angle δ_c between the generator and the system. This happens at the point where the system begins to become unstable. If transient stability studies are not available, a 120-degree angle is widely used within the industry.
5. Define the settings of the blinders. The first one normally is set at the critical angle obtained from the stability study plus 10 degrees to increase relay operation security. The second one is set symmetrical to the first one considering the vertical axis.
6. Determine the blinder distance, d , which is calculated with the following expression:

$$d = \left[\left(\frac{X'_d + X_{TG} + X_{\max SG1}}{2} \right) \cdot \tan \left(90 - \frac{\delta_c}{2} \right) \right] \quad (2)$$

7. Determine the time for the impedance swing to travel between the blinders for the fastest anticipated swing. Note that the swing used in Step 4 to determine δ_c will result in the slowest unstable swing. This value is obtained from an unstable system transient stability study. For implementations of the scheme that requires a minimum traverse time between blinders, the time delay should be set to a value well below the fastest travel time between the two blinders. The setting as suggested by IEEE Standard C37.102 should range from 40 to 100 milliseconds. Setting the delay too long can reduce dependability. A time delay just long enough to prevent misoperation on transients is still secure because a single blinder scheme requires entering from one side and exiting from the other, which can only happen when a pole is slipped.
8. Verify with the transient stability study the settings by checking that the impedance loci enter the mho element outside of the blinders, cross both blinders, and then exits the mho element.

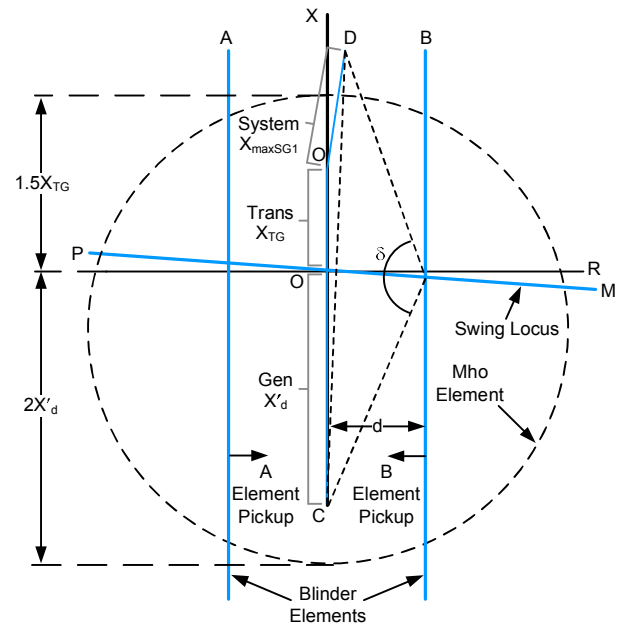

Fig. 10. Procedure to Set Out-of-Step Relays

VII. CASE STUDY

Consider the power system illustrated in Fig. 11 that corresponds to Example 14.9 from [2]. This case study illustrates the procedure to determine the critical clearing time and the travel time within the blinders of an out-of-step relay by means of a transient stability study. The transient stability analysis uses a three-phase fault on Line L₄₋₅ at the connection point to Node 4. (The other relay settings are not illustrated here because they are rather straightforward as they depend on the reactances of the elements.)

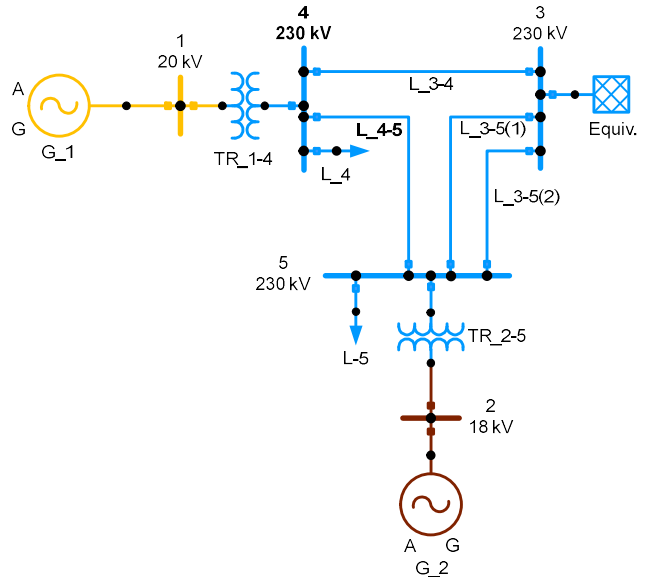

Fig. 11. Example Power System

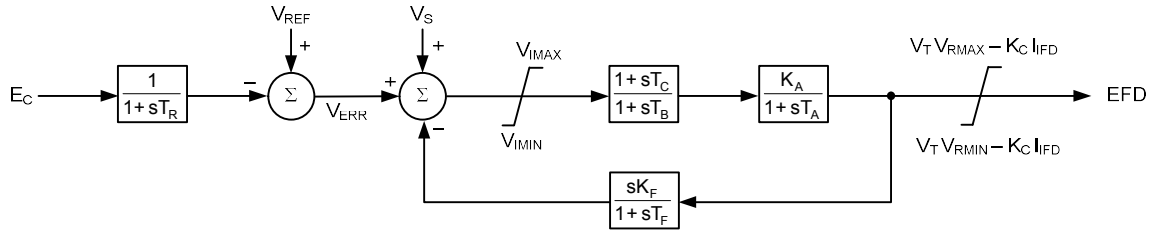

Fig. 12. IEEE Type ST1 Excitation System

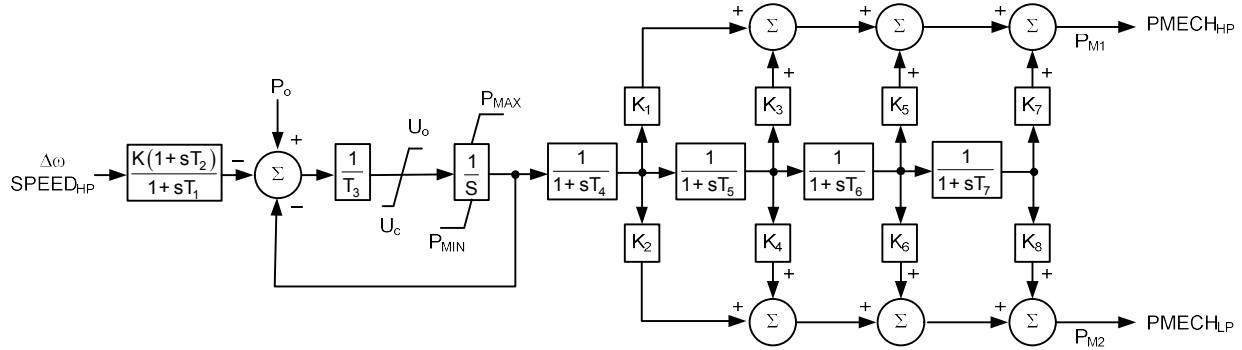

Fig. 13. IEEE Type 1 Speed-Governing Model

A. Considerations

For analysis, consider the following example power system:

- The fault inception is $t = 0.5$ seconds.
- Clearance times starting at $t = 90$ milliseconds (approximately 5 cycles) are analyzed in consecutive steps of 10 milliseconds.
- For simplicity, the fault is removed with the consequent line outage.
- The voltage regulator is an IEEE Type ST1 excitation system. This is a static excitation voltage regulator where the rectifiers provide dc current to supply the generator field. The model represents a system with the excitation power supplied from a transformer that is fed from the generator terminals or from the auxiliary services and is regulated by controlled rectifiers.
- The turbine governor is an IEEE Type 1 speed-governing model. This model represents the speed control (mechanical-hydraulic) and thermal steam turbine.
- For this machine, no power system stabilizer is available.

The models for the excitation system and governor are shown in Fig. 12 and Fig. 13. The excitation system was modeled per [3]. The governor was modeled according to [4].

B. Critical Clearing Time

Determining the critical clearing time is perhaps the most elaborate part of the entire settings process. To achieve this, several simulation cases of the transient stability study are needed to determine when the system loses synchronism or has the first slip. The equal area criteria analysis cited in Chapter 1 can reduce the number of computer simulation cases by providing an estimate of the critical switching time from a stable or unstable case.

C. Maximum Generator Slip

The average slip is obtained from the generator rotor angular change using a time plot. The maximum slip is only of concern to determine if it is within the capability of the relaying scheme. Maximum slip is a function of generator inertia, accelerating torque, and fault-clearing times. Maximum accelerating torques are produced by close-in three-phase faults. Generally considered the worst case, this scenario is studied to determine critical clearing time. This is illustrated in the following example.

VIII. RESULTS

Recall that the transient stability analysis was made for a three-phase fault on Line L_4-5 at the connection point to Node 4 of the system shown in Fig. 11. The solution was obtained by using a commercially available software package.

Numerous cases were run with clearing times starting at t equal to 90 milliseconds with increments of 10 milliseconds in an iterative process until stability was lost. The results of three representative cases were analyzed; the corresponding critical fault-clearing times are shown in Table I.

TABLE I
CRITICAL FAULT-CLEARING TIMES

Case	Fault-Clearing Time (ms)
1	90
2	180
3	190

Several plots from the transient stability simulation cases can be obtained for a myriad of applications. For setting out-of-step tripping elements, the most important information is the rotor angle versus time and $R + jX$ versus time. From the respective plots, Case 1 has a clearing time of 90 milliseconds, and the system remains in synchronism. In Case 2, the system is still in synchronism with a clearing time of 180 milliseconds. For Case 3, the system loses synchronism with a clearing time of 190 milliseconds. From this information, it is evident that the critical time to clear the fault is equal to 180 milliseconds after fault inception.

Fig. 14 presents the rotor angle versus time for the three cases considered, each with a different clearing time t_c . The results with voltage regulator and speed governing systems are presented as solid lines. Dotted lines correspond to the results without these controls. This figure shows that the oscillations die out faster when the voltage regulator and speed governing systems are enabled.

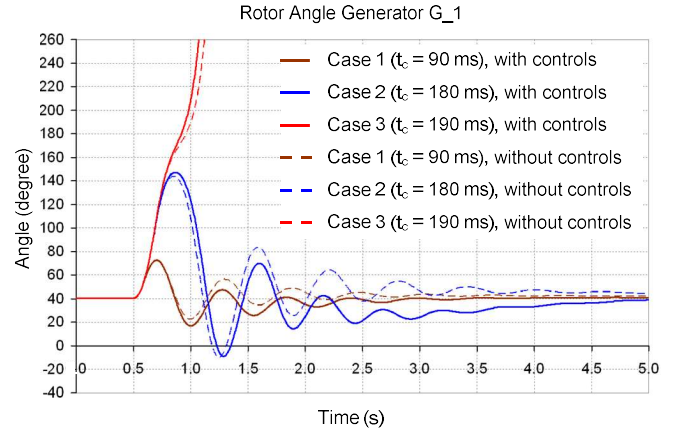

Fig. 14. Rotor Angle Versus Time for the Three Cases Considered

The results for Case 2 show that the critical angle is 145 degrees. Therefore, the first set of blinders is set 10 degrees more at 155 degrees (when t is equal to 810 milliseconds) and the second set of blinders is set at 205 degrees (when t is equal to 1020 milliseconds). This means that the slowest traveling time of the swing load value between the two blinders is 210 milliseconds.

The R-X diagrams for the three cases in Fig. 15, Fig. 16, and Fig. 17 show the trajectory followed by the impedance seen by the relay during disturbances. When there is an oscillation in the generator that is stable, the swing impedance does not cross the line of impedance.

When the generator goes out-of-step, the transient swing crosses the system impedance line each time a slip is completed, and the relay should trip the generator. In Case 1 and Case 2, the apparent impedance does not cross the system impedance line. For Case 3, the load point crosses the system impedance line, indicating that synchronism is lost; therefore, out-of-step tripping must be allowed. Fig. 18 diagrams all three cases and shows a large difference of the load point excursions.

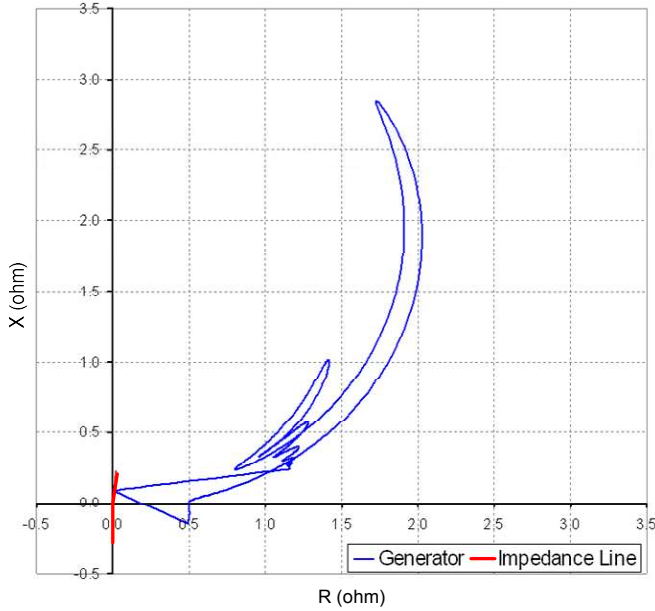

Fig. 15. R-X Diagram for Case 1

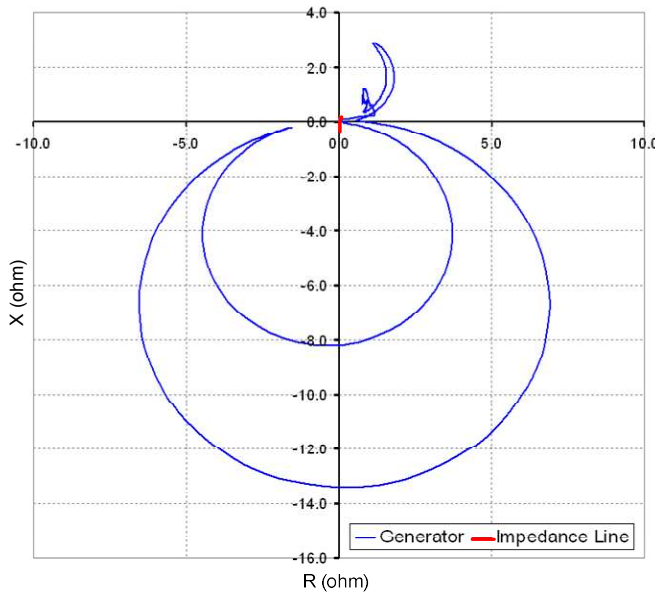

Fig. 16. R-X Diagram for Case 2

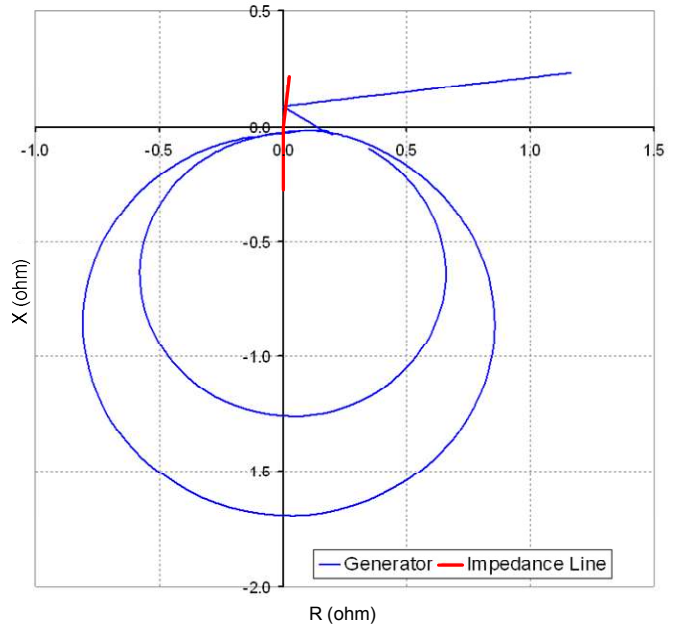

Fig. 17. R-X Diagram for Case 3

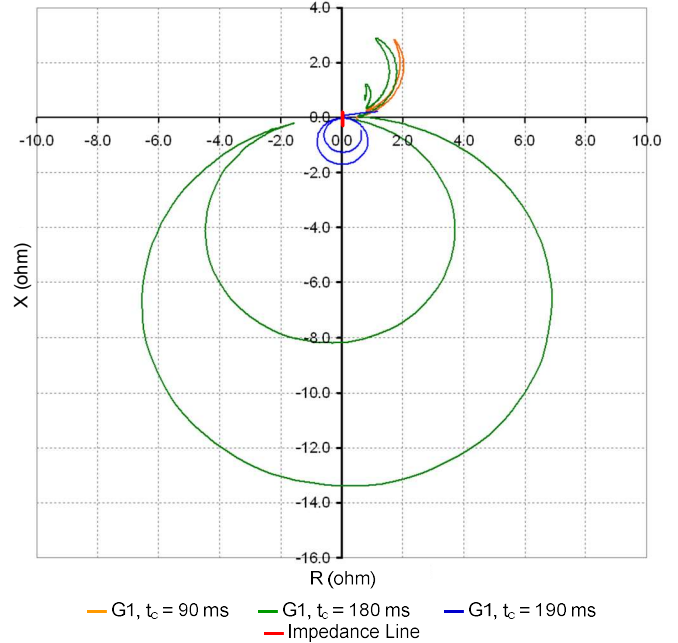

Fig. 18. R-X Diagram for Cases 1, 2, and 3 Simultaneously

The process described, although sometimes tedious and time consuming, helps to determine with confidence the system instability point and the travel time of the load point for each scenario. These values are required to determine the blinder settings and the out-of-step relay timing, as per the procedure indicated in Section VI.

Another consideration is the determination of the most stringent fault. In Section VII, Subsection C, it was mentioned that the maximum accelerating torques are produced by close-in three-phase faults that are illustrated by comparing the results for a three-phase fault at the substation and along the line. The graphs of angle versus time for Generator 1 are

presented with a wider horizontal scale for bolted three-phase faults at Node 4 (Fig. 19) and at 20 percent over Line L_4-5 from Node 4 (Fig. 20).

IX. SIMULATION WITH COMTRADE FILES

The appropriate protective relay response during transient power swings is vital to ensure that the power system will perform adequately. It is important to restrain the operation of the transmission line distance relays with power swing blocking elements and allow the operation of the generator out-of-step relays when synchronism is lost.

For this purpose, the simulation results obtained from commercially available transient simulation programs are converted to COMTRADE (Common Format for Transient Data Exchange) files. IEEE Standard C37.111-1999 defines this file format for transient waveforms and event data collected from power systems or simulations using power system models.

Relay test equipment reproduces voltage and current signals from these files, and the performance of the relays is verified during out-of-step conditions. Analyzing relay performance beforehand with this type of technique verifies that the relay will respond properly for out-of-step conditions.

Sample results are obtained with a transient simulation program and converted to COMTRADE files. Fig. 21 shows the COMTRADE files obtained for the Phase A current of the system shown in Fig. 11, when the fault is cleared 180 milliseconds after its inception.

Testing out-of-step relays to verify performance during out-of-step conditions is easily achieved by loading these COMTRADE files into a test set and replaying them on the relay inputs.



Fig. 19. Angle Versus Time for Generator 1 for Bolted Three-Phase Faults at Line L_4-5 from Node 4



Fig. 20. Angle Versus Time for the Generator 1 for Three-Phase Fault at 20 Percent Over Line L_4-5 at Node 4

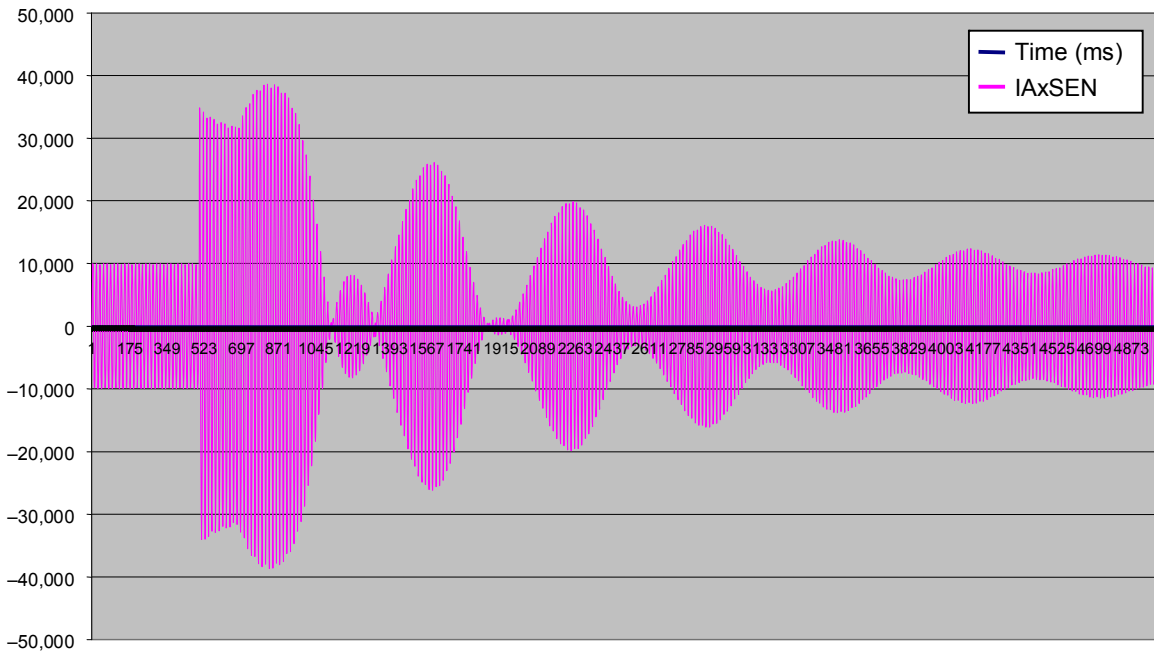

Fig. 21. COMTRADE File Corresponding to the Case Study Phase A Current

X. OUT-OF-STEP TRIPPING MODE

Out-of-step protection schemes should trip just the generator breaker(s) if the generating unit is capable of withstanding load rejection and carrying its own auxiliaries. Tripping only the generator breaker(s) allows the generator to resynchronize once the system has stabilized. If the unit does not have full-load rejection capabilities, it should be shut down.

XI. CONCLUSIONS

This chapter provides general guidelines on the application of out-of-step relaying for generators. This protection should be installed on a generator if the electrical center of the swing passes through the region from the HV terminals of the step-up transformer down into the generator. This condition tends to occur in a relatively tight system or if a low excitation condition exists on a generator. Note that this zone is protected by differential relays that do not respond to power swings. Unit out-of-step protection should also be used if the electrical center is out in the system and the system relays are blocked or not capable of detecting the out-of-step condition.

Out-of-step conditions are simply detected by a mho-distance-type relay oriented to look into the generator and its step-up transformer. The main disadvantages of this protection method are the possibility to trip on recoverable swings and signal the interruption of the generator breaker at an unfavorable swing angle. More sophisticated schemes, such as blinder and lens schemes, minimize the probability of tripping on recoverable swings and permit controlled tripping of the generator breaker at a better swing angle.

Conventional loss-of-field relays offer a limited amount of out-of-step protection for swings deep into the generator impedance, especially if there is any intentional time delay.

Transient stability studies are desirable to determine the behavior of an electrical system subjected to oscillations following power system disturbances and require appropriate system modeling. Among other reasons, transient stability studies should be conducted to properly set out-of-step relays, because the studies provide the critical angle and the travel time of the swing locus between the blinders. These studies are essential for setting double blinder schemes. The results of the transient stability studies can be converted to voltage and current waveform data in COMTRADE format to verify the performance of the out-of-step relays using a relay test set.

In particular, the modeling should include the operation of voltage regulators, governors, and power systems stabilizers as applicable. From the case study, clearly the effect of these elements enhances the performance of the system under transient power swings.

XII. REFERENCES

- [1] J. Berdy, "Out-of-Step Protection for Generators," presented at Georgia Institute of Technology Protective Relay Conference, May 6–7, 1976.
- [2] W. D. Stevenson, *Elements of Power System Analysis*, 4th ed. New York: McGraw Hill, 1982.
- [3] *IEEE Recommended Practice for Excitation Systems Models for Power System Stability Studies*, IEEE Standard 421.5-2005.
- [4] O. Aanstad, G. J. Bartok, D. H. Berry, R. T. Byerly, F. P. DeMello, R. D. Dunlop, D. N. Ewart, B. M. Fox, L. H. Johnson, R. J. Mills, D. W. Tschappat, and C. C. Young, "Dynamic Models for Steam and Hydro Turbines in Power System Studies," *IEEE Transactions on Power Apparatus and Systems*, PAS-92, issue 6, pp. 1904–1915, Nov. 1973.

Voltage Transformer Signal Loss

Christopher Ruckman, Stephen P. Conrad, and Wayne Hartmann

Abstract—Loss of the voltage transformer (VT) signal can occur because of a number of causes, most commonly fuse failure. Other causes may be a VT or wiring failure, an open circuit in the draw-out assembly, an open contact due to corrosion, or a blown fuse due to screwdriver short circuits during online maintenance. Such VT signal loss can cause protective relay misoperation or failure or generator voltage regulator runaway, which can lead to generator overexcitation. This portion of the tutorial identifies schemes to detect the loss-of-voltage signal. Some method of detection is required so that the affected relay tripping can be blocked and the voltage regulator transferred to manual operation.

I. INTRODUCTION

On larger generators, two or more sets of voltage transformers (VTs) are commonly used in the generator zone of protection. The VTs are usually connected grounded wye-grounded wye, normally have secondary fuses or circuit breakers, and possibly have primary fuses. These VTs provide potential to a number of protective relays and the voltage regulator. If a fuse blows in the VT circuits, the secondary voltages applied to the relays and voltage regulator will be reduced in magnitude and shifted in phase angle. This change in voltage signal can cause misoperation of protective relays and the regulator to overexcite the generator. Typically, relay protective functions such as 21, 27, 32, 40, 50/27, 51V, 59D, 67N, 78, and 81 are impacted and normally blocked when the loss-of-potential is detected. If the affected VTs supply a regulator, control should be transferred to manual operation or to another regulator or VT, whichever is appropriate to prevent runaway.

If the overcurrent device (51V) is the only primary fault protection for the unit, it should not be blocked for loss of the voltage signal because the generator would continue to operate without its primary fault protection.

II. FAILURE DETECTION BY VOLTAGE COMPARISON (VOLTAGE BALANCE)

Traditionally, loss of VT signal protection is provided using a voltage balance relay that compares three-phase secondary voltages across two sets of VTs. This scheme is shown in Fig. 1.

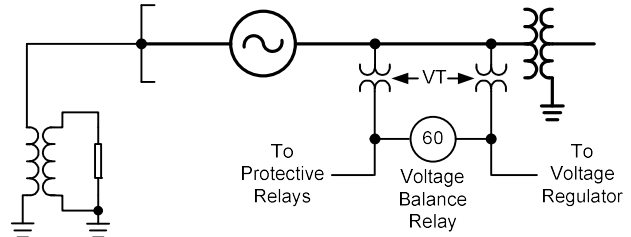

Fig. 1. Application of a Voltage Balance Relay

When a fuse blows in either VT circuit, the voltage relationship becomes unbalanced, and the relay operates. In addition to initiating the blocking and transfer action previously discussed, an alarm is also activated.

Historically, the relay has been set at a voltage unbalance of around 15 percent. When used in conjunction with older, nondigital voltage regulators, however, one potential issue concerning this setting is that corrosion or poor contact of the VT stabs can result in a voltage drop in the circuit. This drop can be significant enough to cause regulator runaway (overexcitation) but too small for detection by the relay. For these applications, a lower setting or an alternate detection scheme should be considered.

III. FAILURE DETECTION BY SYMMETRICAL COMPONENT ANALYSIS

Modern methods of VT failure detection use the relationship between sequence voltages and currents during a loss-of-potential. When one or two VT signals are lost, the three-phase voltages become unbalanced. Because of this unbalance, a negative-sequence voltage is produced. The presence of negative-sequence voltage and the corresponding absence of negative-sequence current indicate a VT failure.

When all three VT signals are lost, the above method cannot be used successfully. Instead, a comparison can be made between the three-phase voltages and three-phase currents. If all three-phase voltages are abnormal (less than 5 percent nominal), the three-phase currents are normal (less than 125 percent nominal), and positive-sequence current is present, a VT failure is declared. A logical seal-in circuit is typically provided to ensure that a VT failure is not declared during a three-phase fault when the current drops below 125 percent of nominal because of generator current decrement during the fault.

These methods are easily implemented in digital microprocessor-based generator protection systems and can be applied when only one set of VTs is on the generator bus.

IV. VT APPLICATION CONCERNS

Two potential concerns regarding the proper application of VTs include ferroresonance and the use of current limiting resistors.

A. VT Ferroresonance and Grounding

Ferroresonance phenomena can occur when wye-wye VTs with grounded primaries are connected to an ungrounded system (see Fig. 2).

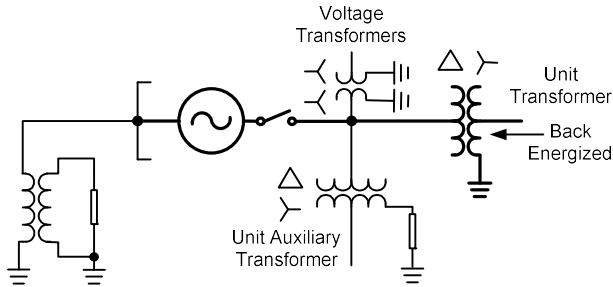

Fig. 2. Generator Zone Configuration That May Produce VT Ferroresonance

This condition can occur in the generator zone if either the generator neutral becomes disconnected or the generator is electrically disconnected from the generator bus and the VTs remain connected to the delta winding of the unit transformer. The likelihood of ferroresonance is enhanced should a higher than normal voltage be impressed across the VT windings during backfeed because of a ground fault or switching surge on the ungrounded system. The higher voltage requires the VTs to operate in the saturated region, which promotes the ferroresonance “current jump” phenomena. These high currents can cause thermal failure of the VTs in a short period of time.

By using line-to-line rated VTs connected line-to-ground, the potential for ferroresonance is reduced. To further suppress ferroresonance, it may be necessary to apply a resistive load across each phase of the secondary winding sufficient to dampen out the oscillations. This solution can be applied on a temporary basis if it is abnormal to disconnect the generator from the generator bus, but it is done for a special, temporary condition such as start up, maintenance, or testing when the generator bus will be back energized, resulting in an ungrounded system. During normal operation, these resistive loads should be removed.

If the generator bus is routinely operated in a back-energized mode with the generator disconnected from the generator bus (as is the case with a low-side generator breaker), permanent ground fault and overvoltage protection

may also be applied. If the grounded wye-grounded wye VTs have an unused secondary winding, they may be connected into a broken delta configuration. By applying a damping resistance across the broken delta less than 15 percent of the per phase VT magnetizing reactance (X_m) but not so low that the VTs exceed their thermal rating, the ungrounded bus system is stable against ferroresonance. The net voltage on the idle or auxiliary VTs secondary windings is negligible until a ground fault develops on the ungrounded bus section that is backfed from the system through the unit step-up transformer delta winding. If a ground fault occurs, high voltage develops across the resistor. Because this voltage can remain for an extended time, the resistor’s power dissipation rating should match the thermal capability of the VTs.

B. Using Current Limiting Resistors

Current limiting resistors are sometimes used in VT circuits supplied from isolated phase buses to ensure that current limiting fuse ratings are not exceeded by fault current levels. Several issues arise regarding the proper application of current limiting resistors. A serious exposure occurs when only one resistor is used per phase with two or more VTs applied. Fig. 3 illustrates this arrangement.

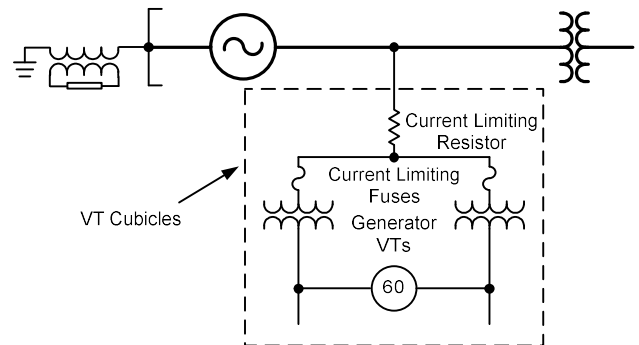

Fig. 3. One Current Limiting Resistor Per Phase (Common Resistor)

When the resistor opens or partially fails, it inserts a high resistance in the circuit. With the open resistor, both VTs are left with identical zero- or reduced-voltage signals. This condition renders the voltage balance relay inoperative and compromises the signal to the connected protection or voltage regulator.

Single-switched voltmeter schemes are impacted if connected to the afflicted phase. An operator may respond to the reduced voltage during a unit startup by inappropriately increasing the field to the point of failure. In situations where this has occurred, equipment damage has resulted.

Providing a current limiting resistor for each VT remedies this problem, thereby eliminating the common mode failure of both VT circuits. Fig.4 shows the suggested circuit arrangement for this solution.

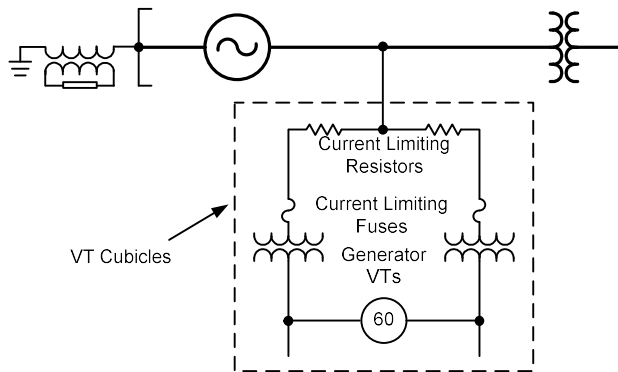

Fig. 4. One Current Limiting Resistor Per VT

When manufacturers provide this arrangement, the potential of the above mentioned conditions are minimized, and the voltage balance relay operates appropriately. Using VT loss-of-potential detection by symmetrical components successfully detects an open resistor when the common resistor arrangement is used.

V. CONCLUSION

Some form of loss-of-potential detection for generator voltage transformers is required. For generator protection security during this condition, it is important to block relay elements dependent upon the voltage signal. If independent loss-of-potential detection is not provided in the voltage regulator, it is important to transfer the voltage regulator from automatic to manual operation during a loss-of-potential event.

Two methods of detection have been discussed in this section of the tutorial as well as two issues that arise when applying VTs. For further background and guidance, consult [1] and other texts addressing the subject of generator protection.

VI. REFERENCE

- [1] *IEEE Guide for AC Generator Protection*, IEEE Standard C37.102-2006.

Inadvertent Energization Protection

Charles J. Mozina and Sudhir Thakur

Abstract—Inadvertent (accidental) energizing of offline synchronous generators has damaged or destroyed a significant number of generators. The frequency of these occurrences has prompted both generator manufacturers as well as IEEE standards to recommend addressing the problem through dedicated protection schemes. This section of the tutorial describes how a generator responds to inadvertent energizing and the subsequent damage that occurs, followed by a discussion of conventional generator protection methods and dedicated protection schemes for detection of inadvertent energizing and generator open breaker flashover.

I. INTRODUCTION

Inadvertent (accidental) energizing of generators occurs frequently enough within the industry to warrant concern. When an offline generator is energized (without field) on turning gear or coasting to a stop, the generator behaves as an induction motor and can be damaged within a few seconds. Turbine damage can also occur. A significant number of large generators have been severely damaged and, in some cases, completely destroyed [1] [2]. The cost to the utilities is not only the repair or replacement cost of damaged generators but also the substantial cost of purchasing replacement power while the unit is out of service. Operating errors, open breaker flashovers, control circuit malfunctions, or combinations of these causes have resulted in inadvertent energizing of offline generators.

A. Operating Errors

Operating errors are increasing within the industry as high-voltage generating stations become more complex with the use of breaker-and-a-half and ring-bus configurations. Fig. 1 shows typical one-line diagrams for two such stations.

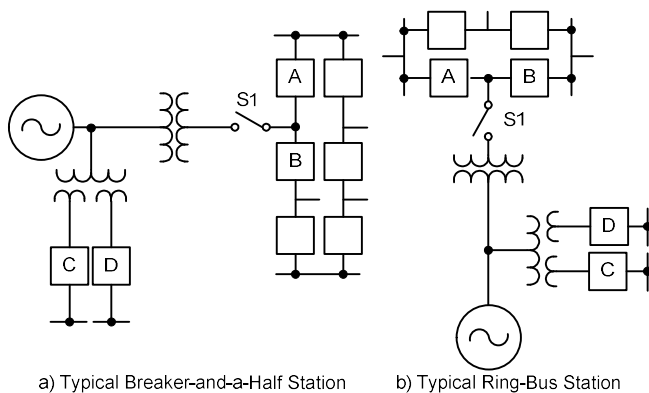

Fig. 1. One-Line Diagrams of Typical Generator Stations

These station designs provide sufficient flexibility to allow a single high-voltage generator breaker (A or B) to be taken out of service without also requiring the unit to be removed from service. Breaker disconnect switches (not shown) are available to isolate the breaker for repair. When the unit is offline, however, generator breakers (A and B) are generally returned to service as bus breakers to complete a row in a breaker-and-a-half station or to complete a ring bus. This practice results in a generator that is isolated from the system through only an open high-voltage disconnect switch (S1). Removing generator straps or other sectionalizing devices in the generator isophase bus can provide additional isolation from the power system. Generally, these isophase bus devices are opened to provide safety clearances or isolation for extended unit outages. In many instances, the high-voltage disconnect switch (S1) provides the only isolation between the generator and the system. Even with extensive interlocks between the generator breakers (A and B) and the disconnect switch (S1) to prevent accidental switch closure, a significant number of cases have been recorded of offline units inadvertently energized through this disconnect switch. The possibility that some or all generator protection, deliberately or unintentionally, may be disabled during this period compounds the problem.

Another path for inadvertent energizing of a generator is through the unit auxiliary system by accidental closure of unit auxiliary transformer breakers (C or D). Due to the higher impedance in this path, the currents and resulting damage are much lower than those experienced by the generator when inadvertently energized from the generator step-up transformer and high-voltage switchyard.

B. Open Breaker Flashovers [3]

The extreme dielectric stress associated with HV (high-voltage) and EHV (extra-high voltage) breakers and the small contact gap spacing associated with their high-speed interrupting requirement can lead to open breaker flashover. This flashover (generally one or two poles) is another method by which generators have been inadvertently energized. The flashover risk is greatest just prior to synchronizing or just after the unit is removed from service. During this period, the voltage across the open generator breaker can be twice normal as the unit slips angularly with the system to 180 degrees out of phase. A loss of SF₆ gas pressure in some types of HV and EHV breakers during this time can result in the flashover of one or more breaker pole(s). This event can energize the generator and cause a significant flow of damaging unbalanced current in the generator windings. This unique

breaker failure condition must be quickly detected and isolated to prevent major generator damage.

Generators connected to the system through low-voltage generator breakers have also been inadvertently energized. Using these generator breakers allows more operating flexibility than the traditional unit-connected configuration. Fig. 2 shows a typical one-line diagram for this design.

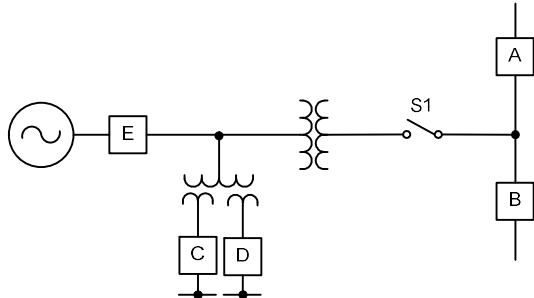

Fig. 2. Station With Low-Voltage Generator Breaker

When the generator is offline, Breaker E is opened to provide isolation from the system. This allows the unit auxiliary transformer to remain energized, carrying load when the generator is out of service, and provides startup power when the generator is brought online. Accidental closures of Breaker E and open breaker flashovers resulting from the loss of dielectric strength have been reported.

II. GENERATOR RESPONSE TO INADVERTENT ENERGIZING

A. Three-Phase Energizing

A generator that is inadvertently energized with three-phase system voltage while on turning gear behaves as an induction motor. During three-phase energizing at standstill, a rotating flux at synchronous frequency is induced in the generator rotor. The resulting rotor current is forced into subtransient paths in the rotor body and damper windings (if they exist), similar to those rotor current paths for negative-sequence stator currents during generator single phasing. The generator impedance during this high-slip interval is equivalent to its negative-sequence reactance. The generator negative-sequence reactance is approximately equal to the average of the direct and quadrature subtransient reactances $(X_d'' + X_q'')/2$. The generator terminal voltage and current during this period will be a function of the generator, unit step-up transformer, and system impedances. When a generator is inadvertently energized, the generator stator current induces high magnitudes of current in the generator rotor, causing rapid thermal heating. This rotor current is initially 60 Hz but decreases in frequency as the rotor speed increases because of induction motor acceleration action.

If the generator is connected to a strong system, the initial stator currents will be in the range of three to four times rating, and the terminal voltage will be in the range of 50 to 70 percent of rating for typical values of generator and step-up transformer impedances. If the generator is connected to a weak system, generator stator current may only be one to two times rating and the terminal voltage only 20 to 40 percent of

rating. When the generator is inadvertently energized from its auxiliary transformer, stator current will be in the range of 0.1 to 0.2 times rating because of the high impedance in this path. The equivalent circuit shown in Appendix I can be used to approximate the initial generator currents and voltages when a generator is inadvertently energized from the power system.

B. Single-Phase Energizing

Single-phase energizing of a generator from the high-voltage system while at standstill subjects the generator to a significant unbalanced current. The unbalanced current causes negative-sequence current flow and thermal rotor heating similar to that caused by three-phase energizing. There will be no significant accelerating torque if the voltage applied to the generator is single-phase and the unit is essentially at standstill. Both positive- and negative-sequence currents will flow in the stator, and each will induce approximately 60 Hz currents in the rotor. This produces magnetic fields in opposite directions—essentially producing no net accelerating torque. If single-phase voltage is applied when the unit is not at standstill but, for instance, at half-rated speed, the accelerating torque due to positive-sequence current will be greater than the retarding torque due to negative-sequence current, and the unit will accelerate.

Open breaker flashover is the most frequent cause of single-phase inadvertent energizing. This situation is most likely to occur just prior to synchronizing or just after the unit is removed from service when the generator and system voltages are 180 degrees out of phase. The initial magnitude of stator current and voltage can be calculated using the symmetrical component equivalent circuit shown in Appendix II for a generator that is energized from one phase and connected to the power system through a delta-wye grounded step-up transformer.

III. GENERATOR DAMAGE DUE TO INADVERTENT ENERGIZING

The initial effect of inadvertent energizing of a generator from standstill or on turning gear is rapid heating in the iron paths near the rotor surface due to stator induced current. These paths primarily consist of the wedges, rotor iron, and retaining rings. The contacts between these components are points where a localized, rapid temperature rise occurs, mainly because of arcing. The depth of current penetration is a fraction of an inch, considerably less than the depth of the rotor windings. Wedges, for example, have little “clamping” load at standstill, resulting in arcing between them and the rotor iron. The arc heating begins to melt the metal and may cause wedges to be weakened to the point of immediate or eventual failure, depending upon the tripping time to clear the inadvertent energizing incident. Damage to rotor windings, if it occurs, results from mechanical damage because of loss of wedge support rather than heating. Because of the low depth of current penetration, the rotor windings would not likely experience an excessive temperature rise and, therefore, would not be thermally damaged.

Generalized heating of the rotor surface to an excessive temperature takes longer than the localized areas described, but if tripping is delayed, the rotor will be damaged beyond repair. The current magnitudes in the stator during this incident are generally within its short-time thermal capability; however, if rotor heating continues, wedges or other portions of the rotor may break off and damage the stator. This may result in total loss of the generator.

The time after which rotor damage will generally occur can be approximated by using the equation for the short-time negative-sequence capability of the generator, $I_2^2 t = K$. When the generator is at or near standstill and is inadvertently energized from either a single- or three-phase source, the value of I_2 used in this formula should be the per-unit magnitude of generator phase current flowing in the machine windings. If the generator is energized from a single-phase source at or near synchronous speed, the negative-sequence component of current should be used. The equivalent circuits in Appendix I and Appendix II can be used to determine the value of current for these situations.

In the case of a cross-compound unit, sufficient field is applied at a very low speed to keep the generators in synchronism as they come up to speed. Inadvertent application of three-phase voltage will attempt to start both generators as induction motors. The thermal hazard to the rotor is the same as when no field is applied and aggravated by the current in the rotor field winding.

Hydroelectric generators are salient-pole generators and are usually provided with damper windings on each pole. These damper windings may or may not be connected together. Inadvertent energizing may create sufficient torque in the rotor to produce some rotation. More importantly, the thermal capacity of the damper winding, especially at the point of connection to the pole steel, is not adequate for the resulting currents. The heating of the connecting points, combined with the lack of proper ventilation, creates damage quickly. Since hydroelectric generator design is unique, each unit needs to be evaluated for the detrimental effects of inadvertent energizing.

IV. RESPONSE OF CONVENTIONAL GENERATOR PROTECTION TO INADVERTENT ENERGIZING

As part of the typical complement of generator protection, the following five protection elements may detect or can be set to detect inadvertent energizing:

- Loss-of-field protection
- Reverse power
- Negative-sequence overcurrent
- Breaker failure
- System backup

A. Disabled Protection

Inadvertent energization protection needs to be in service when the generator is out of service. This is the opposite of normal protection. Frequently, utilities disable generator protection when the unit is offline to prevent undesirable tripping of generator EHV breakers that have been returned to

service as bus breakers in breaker-and-a-half and ring-bus substations. It is also a common operating practice to remove generator voltage transformer (VT) fuses as a safety practice when the generator is removed from service. This disables voltage-dependent relays from providing inadvertent energization protection. Many utilities use auxiliary contacts (52a) of the generator high-voltage disconnect switch to automatically disable generator protection when the unit is offline. This technique can prevent the relays from being operative for inadvertent energization protection. In many cases, engineers who rely on the normal complement of generator relaying for inadvertent energization protection fail to recognize these common operating and/or control practices that disable protection.

B. Loss of Field

Loss-of-field relay schemes are voltage dependent. If the potential source is disconnected when the unit is offline, the loss-of-field relay will not operate. Note that the loss-of-field relay is often removed from service by a disconnect switch and/or breaker 52a contacts when the machine is offline. Therefore, depending upon how the inadvertent energizing occurs, the loss-of-field protection may be disabled. When enabled during an inadvertent energizing condition, the loss-of-field relay may or may not detect this event and should not be relied upon for protection.

C. Reverse Power

The resulting power level from inadvertent energizing will generally be within the pickup range of the reverse power relay. Tripping by reverse power relays is substantially delayed (usually 30 seconds or longer), which is much too long to prevent generator damage. In some types of electromechanical reverse power relays, this time delay is introduced through an ac voltage-operated timer whose pickup level requires that 50 percent of rated terminal voltage be present. If the generator terminal voltage is below this level, the relay will not operate. If the potential supply is disconnected, the reverse power relay may also fail to operate.

D. Negative-Sequence Overcurrent

It is common practice to provide generator protection from external unbalanced conditions that might damage the generator. This protection consists of a time-overcurrent relay that responds to negative-sequence current. Two types of relays are used for this protection: an electromechanical time-overcurrent relay and a static/digital relay with a time-overcurrent characteristic, which matches the $I_2^2 t = K$ capability curve of the generator. The electromechanical relay was designed primarily to provide machine protection for uncleared, unbalanced system faults. The negative-sequence current pickup of this relay is generally 0.6 per unit of rated full-load generator current. The static and digital relays are much more sensitive and capable of detecting and tripping for negative-sequence currents down to the continuous capability of the generator. Therefore, the static and digital negative-sequence relay will detect single-phase inadvertent energizing

for most cases. The response of the electromechanical relay should be checked to ensure that its setting is sufficiently sensitive, especially in applications in which the unit is connected to a weak system. The tripping of these relays may be supervised by a high-voltage switch or breaker 52a contacts that could render them inoperative for open breaker flashover events where the breaker is mechanically open.

E. Generator Breaker Failure

Generator breaker failure must be initiated to isolate a generator for an inadvertent energization condition due to open breaker flashover. A functional diagram of a typical generator breaker failure scheme is shown in Fig. 3.

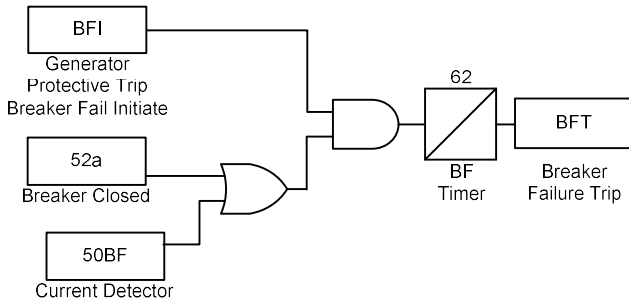

Fig. 3. Generator Breaker Failure Logic

When generator protective relays detect an internal fault or an abnormal condition, they will attempt to trip the generator breakers and at the same time initiate the breaker failure timer(s). If the breaker(s) do not clear the fault or abnormal condition in a specified time, the timer will trip the necessary backup breakers to remove the generator from the system. The current detector (CD) and the breaker 52a auxiliary contact are used to detect that the breaker has successfully opened. The breaker 52a auxiliary contact must be used in this case because faults and/or abnormal generator conditions will not produce sufficient current to operate the CD. If one or two poles of a breaker flash over to energize a generator, two conditions must be satisfied to initiate breaker failure:

- The flashover must be detected by a generator protective relay that initiates the breaker failure relay.
- The breaker failure CD must be set with sufficient sensitivity to detect the flashover condition.

F. System Backup Relays

Impedance (with reverse reach) and voltage-restrained or controlled overcurrent relays that are used to provide backup for generator protection can be adjusted to provide detection of three-phase inadvertent energizing. However, their operation should be checked by comparing their settings with expected generator terminal conditions for inadvertent energizing. These backup relays have a time delay associated with tripping that is generally too long to prevent generator damage. Attempts to reduce this time delay usually result in false tripping for stable power swings or loss of coordination under fault conditions. Also, operation of the particular type of relay used should be reviewed for the condition when polarizing or restraining potential has been disconnected.

V. DEDICATED PROTECTION SCHEMES TO DETECT INADVERTENT ENERGIZING

Because of the severe limitation of conventional generator relaying to detect inadvertent energizing, dedicated protection schemes have been developed and installed [4]. Unlike conventional protection schemes that provide protection when equipment is in service, the dedicated schemes provide protection when equipment is out of service. Thus, great care should be taken when implementing this protection so that dc tripping power and relay input quantities to the scheme are not removed when the protected unit is offline.

This section describes a number of dedicated inadvertent energization protection schemes for units without low-voltage generator breakers. The judicious selection of input sources allows most of these schemes to be applied to generators with low-voltage generator breakers. Whatever scheme is used to provide protection for inadvertently energizing a generator, the protection should be connected to trip the generator high-voltage and field breakers, trip the unit auxiliary breakers, initiate generator high-voltage breaker failure backup tripping, and not disable the protection when the generator is out of service.

A. Directional Overcurrent

The directional overcurrent scheme has three directional inverse-time overcurrent relays that use current and voltage sensing from the generator terminals. Choosing a relay with a maximum sensitivity angle combined with the current transformer connection is necessary to ensure that the underexcited loading capability of the generator is not appreciably impaired. The setting used may involve a compromise between desired sensitivity and a setting at which the relay will not be thermally damaged by generator full-load current. This scheme is dependent on potential available for operation. Thus, if operating procedures dictate removing voltage transformer fuses when the generator is offline, this scheme is not recommended.

B. Frequency Supervised Overcurrent

The frequency supervised overcurrent scheme uses a combination of frequency and overcurrent relays that are only enabled when the generator is offline. The current relays are instantaneous overcurrent with a pickup setting of about half of the expected inadvertent energizing current. The underfrequency relays are set to close their contacts when the frequency falls below the setting that is in the range of 48 to 55 Hz, thus enabling the overcurrent relay. This scheme requires pickup and dropout time delays and voltage balance supervision to prevent misoperation. For this scheme to work properly, the underfrequency relay contact needs to be closed when there is no voltage. Underfrequency relays that do not operate below 50 percent voltage should not be used for this application.

C. Distance Relay

A number of schemes are available that use distance relays polarized to respond to current flow into the generator from

the high-voltage switchyard. The distance relay is set to detect the sum of the reactance of the unit step-up transformer and generator negative-sequence reactance with appropriate margin. In some cases, the distance relay is supervised by an instantaneous overcurrent relay to prevent false operation on loss-of-potential. Because the impedance relay may operate for stable power swings, a thorough stability analysis is required to ensure the relay will not operate for such swings. Additional protection is required for single-phase energizing, because the distance relay has limited capability to detect this condition. Also, to prevent undesirable operations on stable swings, a 0.1-second delay of relay operation may be desirable.

D. Voltage Supervised Overcurrent

The voltage supervised overcurrent scheme, shown in Fig. 4, uses phase undervoltage elements with pickup and dropout time delays to supervise instantaneous overcurrent tripping relays. After a time delay, the undervoltage element automatically arms the overcurrent relays when generation is taken offline. When voltage exceeds the undervoltage relay setting, the scheme is disabled after a time delay (dropout time) so that it is not in-service when the generator returns to service. Setting the undervoltage element below 50 percent of nominal ensures that the overcurrent element does not arm during stressed system conditions. This scheme uses potential from the generator voltage transformers but will work properly even if voltage transformer fuses are removed when the generator is offline. Voltage balance relay supervision or other VT fuse loss detection logic is required to prevent possible misoperation that may result from loss-of-potential due to VT fuse blowing. Some digital relay loss-of-potential schemes use the following logic. If current is detected with no voltage, a loss-of-potential condition exists. This logic blocks the inadvertent energizing scheme for events when VT fuses are removed while the generator is offline. In some schemes, loss-of-potential security is provided by requiring all three phase voltages be below the voltage relay setting. This scheme is well suited for location in the transmission switchyard, where the scheme is less likely to be accidentally removed from service during generator maintenance [5]. This is the most popular scheme for inadvertent generator energization protection and has been incorporated into many digital generator multifunction relays.

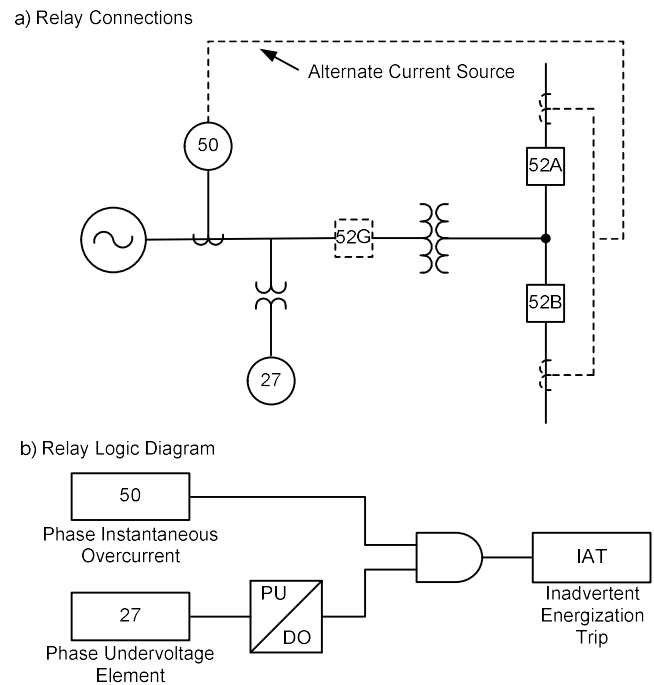

Fig. 4. Voltage Supervised Overcurrent Scheme

E. Auxiliary Contact-Enabled Overcurrent

The auxiliary contact-enabled overcurrent scheme uses the generator field breaker auxiliary contacts to enable nondirectional instantaneous overcurrent relays when the field breaker is either open or racked out. In some cases, a speed switch is used. Overcurrent relays are set for 50 percent of the minimum accidental energizing current.

Coordination time delays are used to prevent misoperation. Although this scheme will not provide protection after the field is applied to the unit, it is preferred over the scheme that uses the auxiliary contacts of a motor-operated disconnect and high-voltage generator breakers to supervise the same nondirectional instantaneous relays. This latter scheme will provide accidental energization protection regardless of the frequency or voltage applied to the unit. The drawbacks to this scheme are the complexity of the contact logic and the unreliability of the auxiliary contacts, particularly those on the motor-operated disconnect. This kind of offline supervision should be avoided. **Caution:** If the motor is disengaged from the disconnect switch such that the auxiliary contacts do not follow the switch position, inadvertent energization protection may not be enabled when required to operate.

F. Overcurrent Supervised by Multiple Elements

Security is enhanced by using a combination of elements to supervise the low-set nondirectional overcurrent element. One common scheme requires an AND condition of field breaker open, low terminal voltage, and low current to determine the unit is offline and arm the protection. See Fig. 5. The scheme is armed several seconds after the unit is determined to be offline when all three conditions are true. The dropout delay of the arming/disarming timer provides a window of opportunity to trip on overcurrent when voltages and/or currents are detected during the inadvertent energization event. After the dropout delay, the scheme is disarmed once the field breaker is closed as the unit prepares for synchronization. The short tripping delay is included to ride through inrush current that may occur when the field is applied. The trip delay timer must be set shorter than the arming/disarming timer dropout delay.

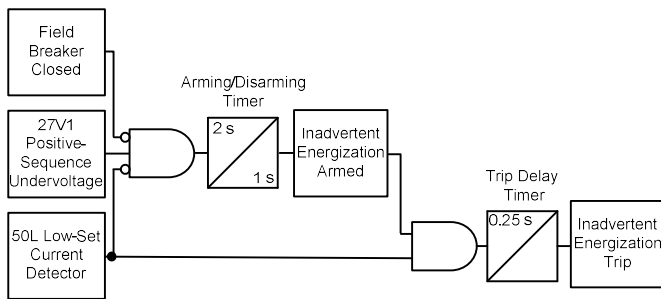

Fig. 5. Multiple Element Supervised Scheme

VI. DEDICATED PROTECTION SCHEMES TO DETECT GENERATOR OPEN BREAKER FLASHOVER

For the flashover of a generator high-voltage breaker pole, retripping the breaker will not de-energize the generator. The initiation of breaker failure relaying is required to trip additional local and possibly remote breakers to de-energize the generator. Some of the schemes discussed in the Section V can be set to detect open breaker flashovers and provide protection in conjunction with generator breaker failure protection. Chapter 2.5 describes details of generator breaker failure protection. Other schemes are inoperative when the generator is near rated speed and voltage prior to synchronizing and must be supplemented by additional protection.

Unbalanced currents associated with open breaker flashover generally cause the generator negative-sequence overcurrent protection to operate. Breaker failure initiates if the breaker failure current detectors are set with sufficient sensitivity to detect the situation. Schemes specifically designed to speed up the detection and isolation of this unique form of breaker failure are described next.

A. Modified Breaker Failure Logic

One approach to speed up the detection of an open breaker flashover is to modify the breaker failure scheme as shown in Fig. 6. An instantaneous overcurrent relay (50G) is connected in the neutral of the generator step-up transformer and set to respond to an EHV open breaker flashover. The relay output is supervised by the generator breaker 52b auxiliary contact

that provides an additional start to the breaker failure scheme. When the generator breaker is open and one or two poles of the breaker flash over, the resulting transformer neutral current is detected by the 50G relay without the delay that would be associated with negative-sequence overcurrent or some of the previously described inadvertent energizing schemes. The CDs associated with the generator breaker failure scheme *must* be set with sufficient sensitivity to detect this flashover condition.

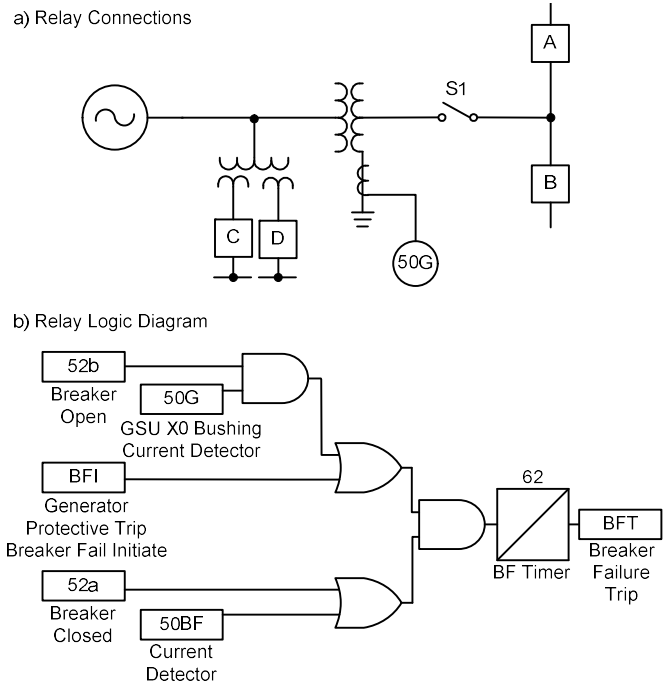

Fig. 6. Modified Breaker Failure Logic

B. Breaker Pole Disagreement

In general practice, high-voltage EHV breakers are designed with independent pole operating mechanisms. For unsymmetrical pole closures, the breakers are protected by an interconnection of auxiliary contacts. If any pole is closed at the same time that another is open, a path is provided to initiate tripping of the breaker. Because breaker auxiliary contact indications do not provide positive indication of pole position, these schemes can be augmented by a relay that monitors three-phase current flowing through the breaker and senses whether any phase is below a certain low threshold level (indicating an open breaker pole) at the same time that any other phase is above a substantially higher threshold level (indicating a closed or flashed-over pole). For breaker-and-a-half and ring-bus applications, zero-sequence voltage across the breaker is used to supervise the relay tripping. This prevents false operation due to unbalanced currents caused by dissimilarities in bus-phase impedances. Thus, this current-monitored pole disagreement relay provides a method of detecting generator open breaker flashovers, but tripping is generally delayed 0.5 seconds. Reference [6] provides a detailed description of this relay.

VII. CONCLUSIONS

Inadvertent energizing of synchronous generators has become a significant problem within the industry as generating stations have become more complex. The widespread use of breaker-and-a-half and ring-bus schemes adds significant operating flexibility to high-voltage generating stations. These configurations have also increased complexity and the risk of the generator being inadvertently energized while offline. Operating errors, open breaker flashovers, control circuit malfunctions, or combinations of these conditions may result in inadvertently energized generators.

Because damage to the generator can occur within a few seconds, the event must be detected and isolated by automatic relay action. Although there are relays used as part of the normal complement of generator protection, their ability to detect inadvertent generator energizing is often marginal. These relays are generally disabled at the time when the generator is inadvertently energized, or they operate too slowly to prevent damage to the generator and/or turbine. For these reasons, turbine generator manufacturers have recommended, and many utilities are installing, dedicated inadvertent energization protection schemes.

The major schemes in service in the United States have been described in this section of the tutorial. These schemes vary because of the different operating practices and protection philosophies of utilities. Protection engineers must assess the risks and determine the impact on protection philosophies and their company operating practices prior to deciding which scheme best suits their particular needs. It is hoped that this information will assist in that task.

VIII. APPENDIX I

Fig. 7 and the following equations show the calculation of initial currents and voltages when a generator is energized from a three-phase source.

The following terms are used in Fig. 7:

- X_{1S} = system positive-sequence reactance
- X_{1T} = transformer positive-sequence reactance
- X_{2G} = generator negative-sequence reactance
- R_{2G} = generator negative-sequence resistance
- E_S = system voltage
- E_T = transformer high-side voltage
- E_G = generator terminal voltage

where:

I = current

$P_{3\phi G}$ = generator three-phase power

$$I = \frac{E_S}{X_{1S} + X_{1T} + X_{2G}}$$

$$E_G = (I) (X_{2G})$$

$$E_T = (I) (X_{2G} + X_{1T})$$

$$P_{3\phi G} = 3I^2R_{2G}$$

IX. APPENDIX II

Fig. 8, Fig. 9, and Fig. 10 illustrate the calculation of initial currents and voltages when a generator is energized from a single phase source such as an open breaker flashover just prior to synchronizing.

Fig. 9 assumes that flashover occurs when generator and system voltages are 180 degrees out of phase. If there is no field on the machine at the time of inadvertent energizing, the E_G voltage source is zero in the positive-sequence equivalent circuit, where:

X_{1G}, X_{2G}, X_{0G} = generator positive-, negative-, and zero-sequence reactances

X_{1T}, X_{2T}, X_{0T} = unit step-up transformer positive-, negative-, and zero-sequence reactances

X_{1S}, X_{2S}, X_{0S} = system equivalent positive-, negative-, and zero-sequence reactances

E_G = generator voltage

E_S = system voltage

I_1, I_2, I_0 = positive-, negative-, and zero-sequence currents

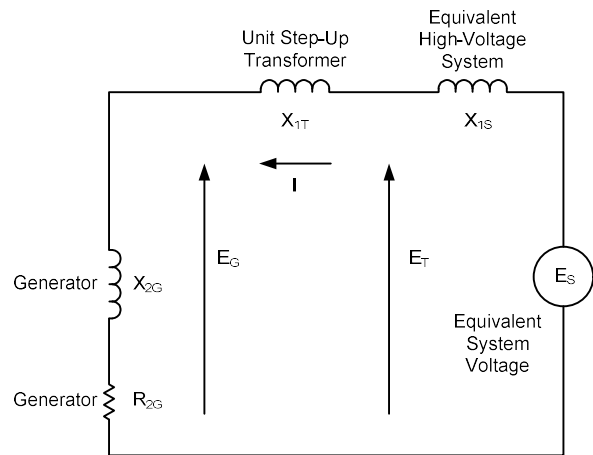

Fig. 7. Approximate Equivalent Circuit

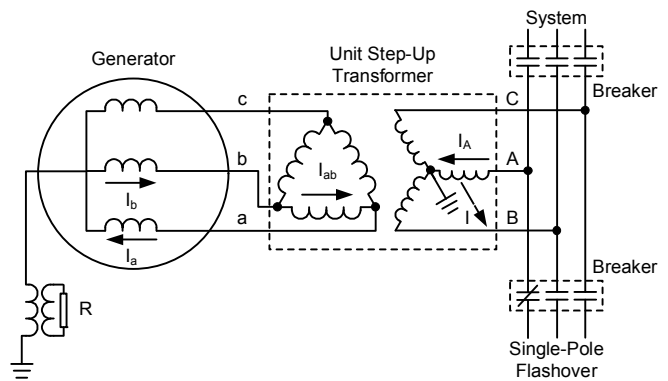

Fig. 8. Open Breaker Flashover

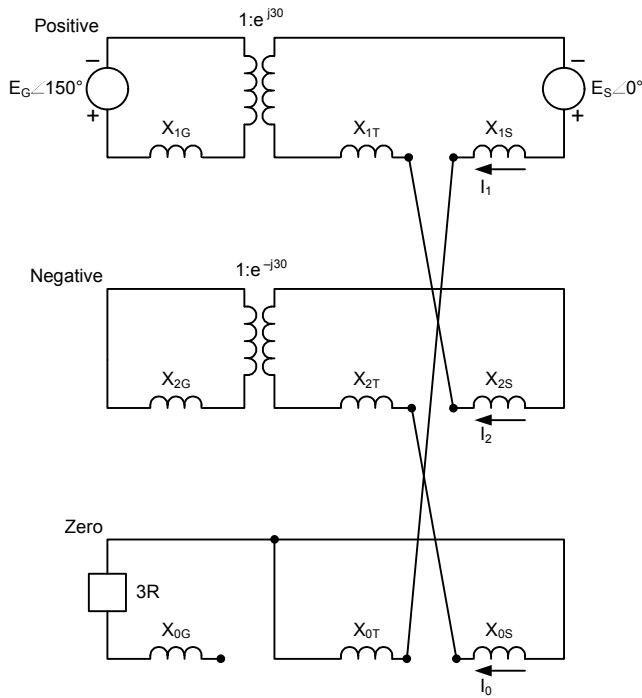

Fig. 9. Symmetrical Component Equivalent Circuit

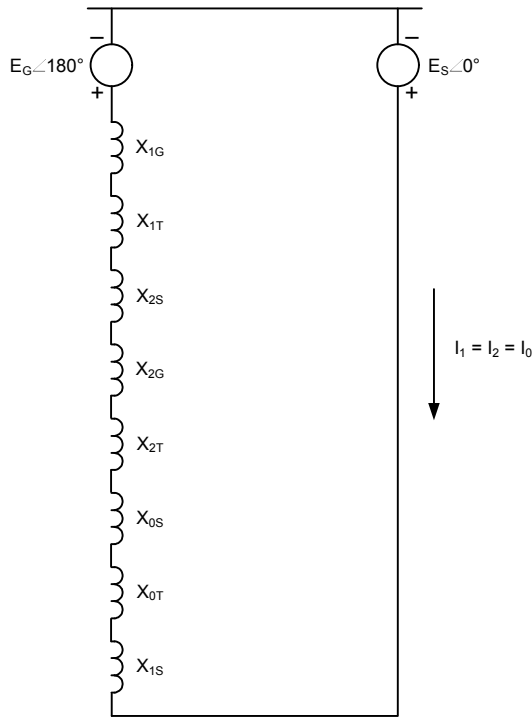

Fig. 10. Simplified Equivalent Circuit

X. REFERENCES

- [1] C. J. Mozina, R. F. Arehart, J. Berdy, J. J. Bonk, S. P. Conrad, A. N. Darlington, W. A. Elmore, H. G. Farley, D. C. Mikell, G. R. Nail, H. O. Ohmstedt, A. C. Pierce, E. T. Sage, D. E. Sanford, L. J. Schulze, W. M. Strang, G. Stranne, F. Tajaddodi, and T. W. Wiedman, "Inadvertent Energizing Protection of Synchronous Generators," *IEEE Transactions on Power Delivery*, vol. 4, issue 2, pp. 965-977, Apr. 1989.
- [2] E. R. Detjen, "Some Additional Thoughts on Generator Protection," proceedings of the Pennsylvania Electric Association Relay Committee, May 1981.
- [3] J. G. Manzek and J. T. Ullo, "Implementation of an Open Breaker Flashover and Inadvertent Energization Protection Scheme on Generator Circuit Breakers," proceedings of the Pennsylvania Electric Association Relay Committee, Sep. 1983.
- [4] *IEEE Guide for AC Generator Protection*, IEEE Standard C37.102-2006.
- [5] M. Meisinger, G. Rockefeller, and L. Schulze, "RAGUA: Protection Against Accidental Energization of Synchronous Machines," proceedings of the Pennsylvania Electric Association Relay Committee Meeting, Sep. 1983.
- [6] W. A. Elmore and C. L. Wagner, "Pole Disagreement Relaying," proceedings of the 10th Annual Western Relay Conference, Spokane, WA, Oct. 1983.

Other Protective Considerations

Patrick M. Kerrigan and Joe T. Uchiyama

Abstract—This part of the tutorial deals with other protective considerations of generators. Topics include the following:

- Considerations during gas turbine static starting
- Considerations for pump storage applications
- Switching near generators
- Synchronizing
- Synchronous condenser operation
- Protection during startup and shutdown
- Subsynchronous resonance

I. CONSIDERATIONS DURING GAS TURBINE STATIC STARTING [1] [2]

Large gas turbines are usually started using the generator as a motor. The generator is run as a synchronous motor supplied by a static frequency converter. The drive operates in a forced commutated mode at very low speeds until the electromagnetic force of the synchronous machine is sufficient to commutate the inverter. Thereafter, it operates in a load-commutated mode. The adjustable speed drive is connected to the generator bus so that generator terminal-side and neutral-side CTs (current transformers) see the same current. The gas turbine may be run for many minutes at different low speeds, while a purging cycle and firing cycle are completed, before it finally accelerates to normal operating speed. V/Hz is maintained constant as speed is increased until the voltage reaches drive-rated voltage, and thereafter voltage is held constant.

When the generator is operating at low frequencies, the normal protection has some limitations. Generally, gas turbines are protected by multifunction protective relay systems. These relays normally track frequency within a specified range. They continue to sample and calculate the currents and voltages at a sampling rate that is a constant multiple of actual frequency. Over the specified frequency range, the various protection functions operate within their specified accuracy limits. Below the frequency tracking range, the sampling rate no longer matches the system frequency, and the accuracy of various elements generally deviates outside of specification.

Manufacturers may supply curves of element performance versus frequency. If a protective function characteristic can falsely operate at low frequencies, it must be disabled below that frequency threshold. In some installations, single function relays with good performance at low frequency have been applied to provide additional protection during start up.

The adjustable speed drive also has protective functions that provide some protection for the generator stator. Typically they include phase overcurrent, phase unbalance,

and ground protection. The ground protection is likely to be insensitive if the generator is high-impedance grounded.

One fault that is not detected by either the conventional generator protection or the protection built in to the adjustable speed drive is a fault on the dc bus of the rectifier/inverter. For this fault, a dc current flows through the fault and any ground in the ac system (see Fig. 1). If the generator is grounded through a high-impedance grounded system (a distribution transformer and a secondary grounding resistor) and has wye-connected VTs (voltage transformers), the fault current divides between these two paths (generator ground and VT neutrals to ground). The dc current causes the magnetic elements to saturate, and the fault current flow is limited only by the dc resistances. The generator, the neutral grounding transformer, and the VTs have limited thermal capability to withstand the dc currents flowing through them.

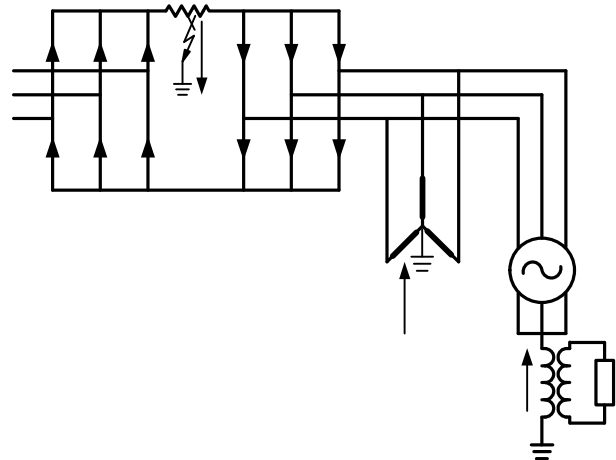

Fig. 1. Fault on DC Link of Static Starter

Many installation designs create a system without any ac grounds during starting. A switch is installed in the generator neutral to remove the neutral ground during starting, and the VTs are connected in delta. This ensures that no dc current flows for a fault in the dc link and that saturation of magnetic elements is avoided. Because the VTs are ungrounded, third-harmonic terminal voltage is unavailable, and 100 percent stator ground fault protection is provided by the neutral third-harmonic undervoltage method.

An alternative approach used in some installations keeps the generator neutral grounded during starting and detects a fault on the dc link by measuring the dc current in the generator neutral. For these faults, the VTs are usually the most limiting components, requiring very quick removal of the fault—as fast as 50 milliseconds, including the time taken

to turn the adjustable speed drive off. On generators grounded through a resistance-loaded distribution transformer, protection schemes have been applied using a resistor/dc transducer between the grounding transformer neutral and ground. The output of the transducer is connected to a sensitive dc relay. Calculations and tests have confirmed the acceptable performance of this protection. The setting is determined by equipment withstand and relay sensitivity. At low speeds, there may not be enough driving voltage to trip the relay.

In some installations, the generator is high-resistance grounded through a resistor connected directly in the generator neutral circuit. For this type of installation, protection against faults in the dc link has been provided in a similar fashion to the previously discussed example by using a dc transducer and a dedicated dc relay.

II. CONSIDERATIONS FOR PUMPED STORAGE APPLICATION

The purpose of a pumped storage hydroelectric installation is to store energy during off-peak periods to be used for generation during peak demand periods. Water is pumped from a lower reservoir to an upper reservoir where it is stored for later use to generate electricity. Most pumped storage units are designed for reversible operation, rotating in one direction as a turbine/generator and in the other direction as a motor/pump. Reversal of direction is accomplished by switching two phases of the main electrical connections using either switches or two breakers, thus changing the phase sequence.

The requirement to reverse rotation introduces the major differences in protection between pumped storage and conventional hydroelectric units. Each protective element must see the appropriate current and voltage transformer connection inputs for proper operation when the phases are reversed.

A. Protection With Discrete Relays [3]

Fig. 2 shows a typical arrangement of single function relays to protect a pumped storage hydroelectric unit in either the generating or pumping mode.

Depending on the location of the CTs and the VTs relative to the reversing switch or breakers, the CT and/or VT connections may also have to be switched to maintain proper connections to the relays in both generating and pumping modes.

For example, in Fig. 2, the generator differential is fed from CTs inside the reversing switch, so the connections to the differential relay do not have to be switched as the mode of operation is changed. However, the CTs for the overall differential are on different sides of the mode-changing switch, so the CT connections have to be switched to maintain

proper inputs to the transformer differential relays. For this example, the CT connections to the negative-sequence, loss-of-excitation, and phase distance relays also have to be switched.

Depending on the VT location, the connections to the VTs may also need to be switched. Fig. 2 shows that the VT inputs to the backup distance and loss-of-excitation elements are switched with the mode of operation.

Table I describes the device numbers that are used in Fig. 2, Fig. 3, and Fig. 4.

TABLE I
DEVICE NUMBER DEFINITIONS

Device Number	Relay
21	Mho Phase Distance Unit Backup
24	Overexcitation or V/Hz
26	Locked Rotor Protection
27	Undervoltage
32	Directional Power
37	Underpower
40	Loss-of-Excitation
46	Negative-Phase-Sequence Overcurrent (OC)
47	Phase Sequence Voltage
47G	Phase Sequence for Generator Mode
47M	Phase Sequence for Motor Mode
48	Incomplete Sequence
49	Generator/Motor Thermal
50	Subsynchronous OC Near 10-15 Hz
51/51V	OC Backup
51DP	Damper Pullout OC
59	Overvoltage (OV)
59N/59SN	Stator Ground OV
51N	Generator/Motor Neutral OC
59N/B	Bus Ground OV
60	Voltage Balance
64F	Field Ground
64S	Stator Ground by Injection
78	Phase Measurement/Out-of-Step
81G	Overfrequency
81M	Underfrequency
87G	Generator/Motor Unit Differential
87M	Motor Differential
87T	Main Transformer Differential
87O	Overall 87G/87T Differential

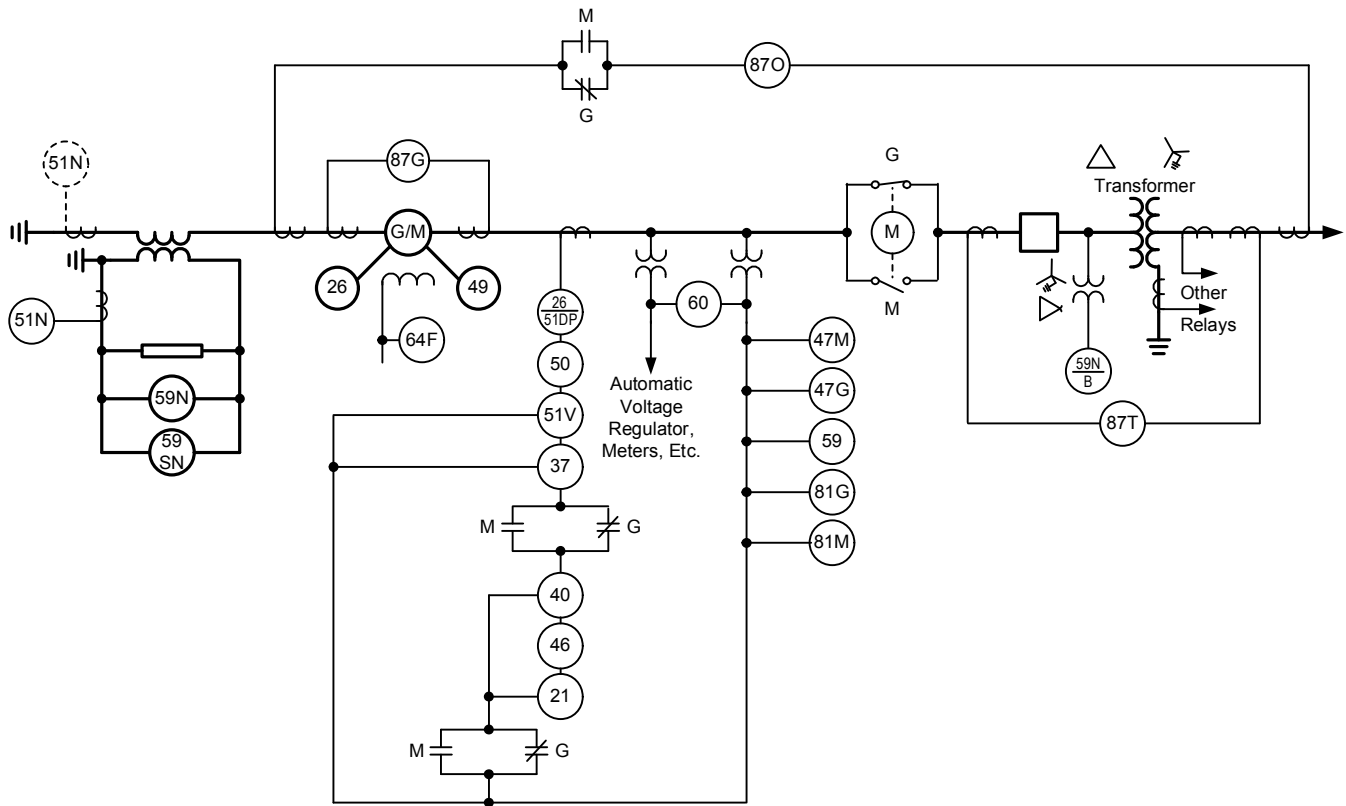

Fig. 2. Typical Protection for Pumped Storage Units Using Discrete Relays

B. Protection With Multifunction Protection Systems

There are two approaches to applying multifunction protection systems to protect pumped storage units. The first method uses two sets of relays, one for the generating mode and the other for the pumping mode, each wired for the appropriate phase connections. The second method uses one relay for both modes. The following describes each of these two methods:

1. Fig. 3 illustrates this approach with System 11G protecting the unit for generating mode and System 11M protecting the unit for the motoring mode. Note that in this example, some of the protective functions in each multifunction relay are used in both motor and generator modes. The 40 element is one example. It is only enabled in System 11G but active in both generator and motor modes.
2. Fig. 4 shows that an input is provided to the relay to change from one settings group to another, depending on the mode of operation. Relays applied for this application typically do not need to have the CT or VT connections externally switched as the mode is changed. Instead, they use internal logic to ensure that the appropriate currents and voltages are used by each element.

In addition to eliminating the need for switching CT and/or PT connections as the mode of operation changes, multifunction protection systems have these additional advantages:

- They occupy less panel space compared with the many single-function relays needed to provide equivalent protection.
- They can be economically duplicated for reliability and to facilitate in-service testing.
- They require less wiring and are easier to set up for testing.
- They provide self-diagnostics, sequence of event records, and wave captures for post-fault analysis.

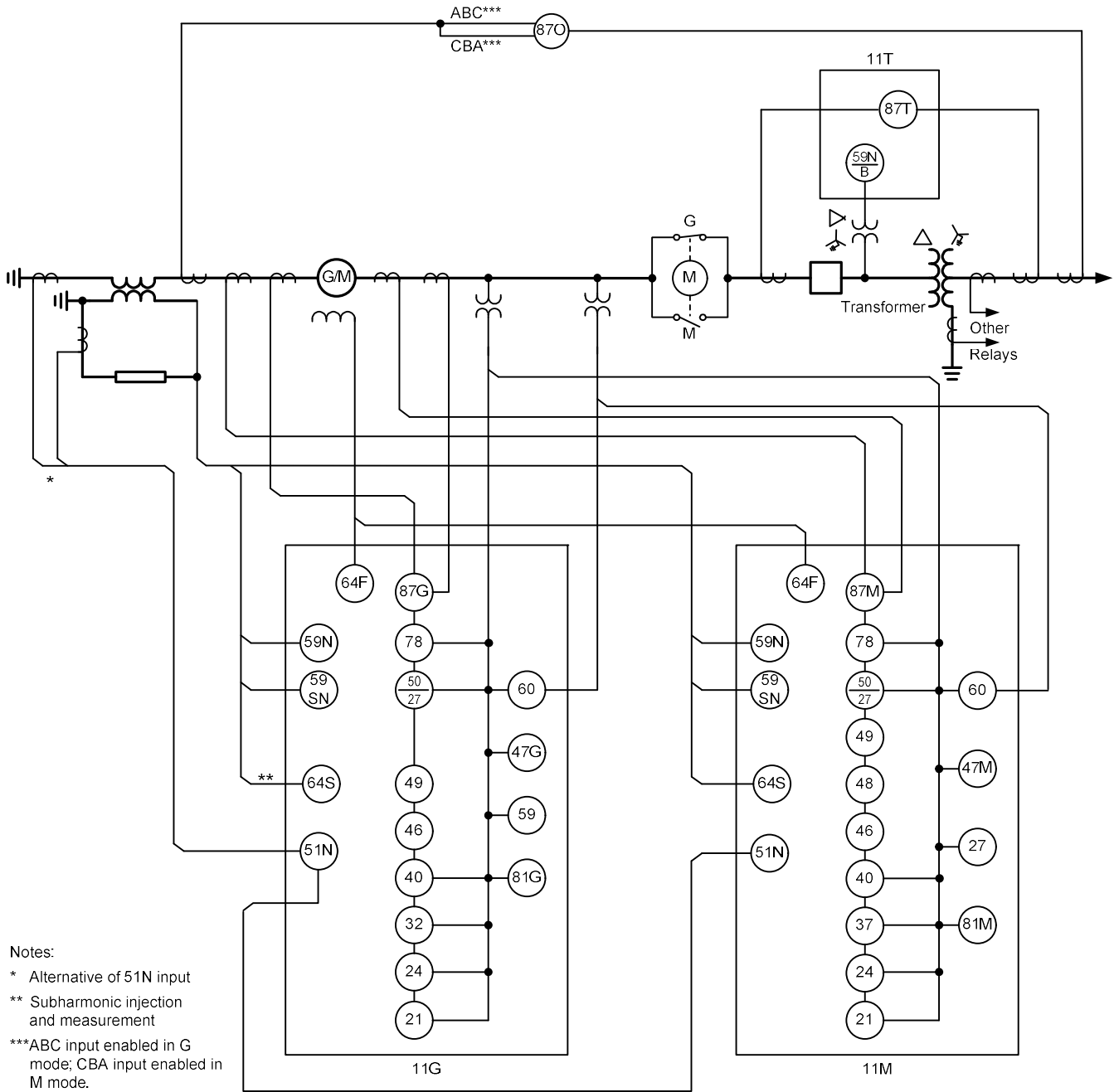

Fig. 3. Typical Protection for Pumped Storage Units Using Two Multifunction Relays

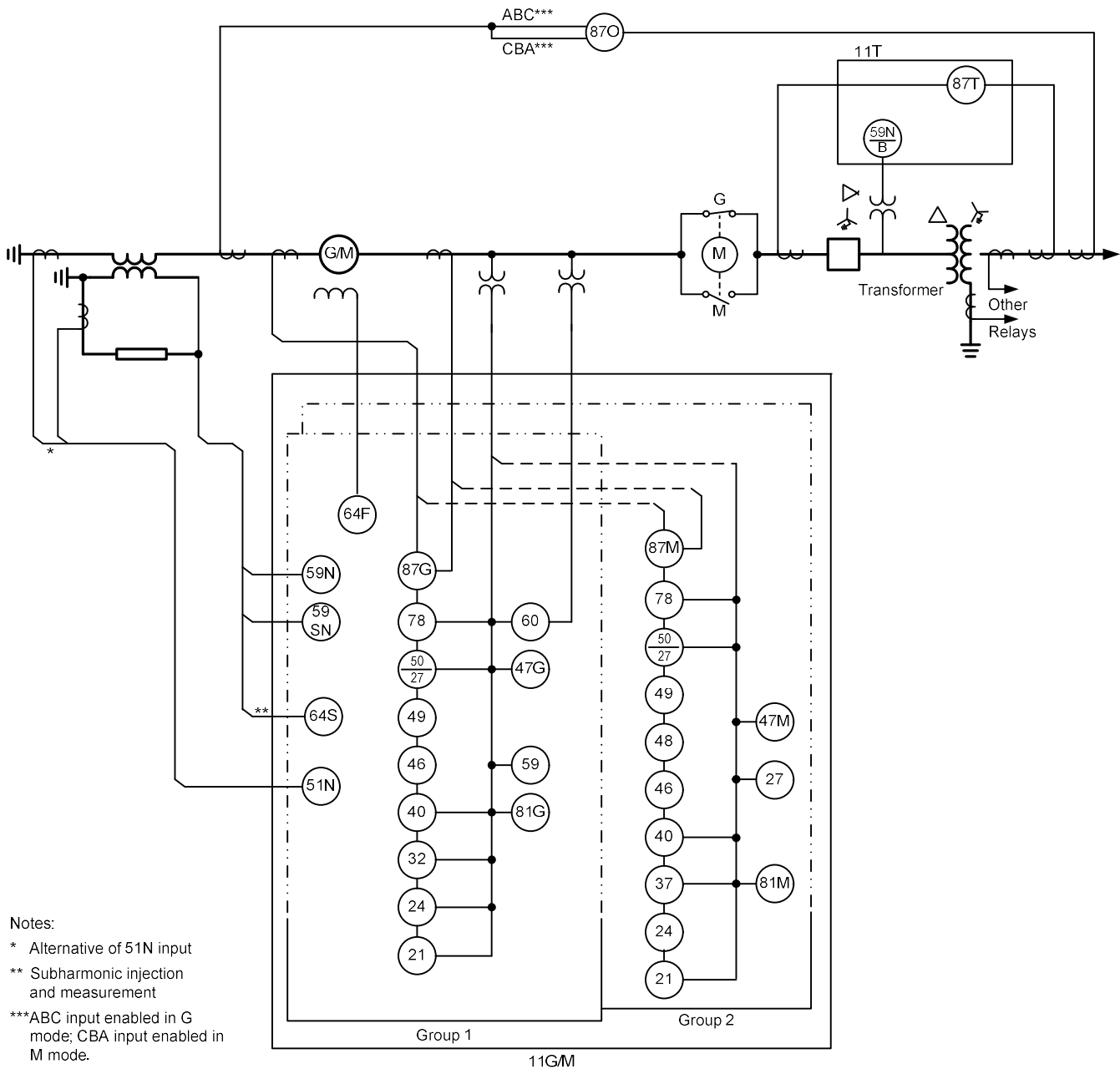

Fig. 4. Typical Protection for Pumped Storage Units Using Two Group Settings on One Multifunction Relay

III. SWITCHING NEAR GENERATORS [1]

Switching operations involving the opening and closing of circuit breakers at or near a generating station may produce transient power and current oscillations that may stress or damage turbine generators. Of particular concern are the switching operations that produce torsional oscillations and shaft torques that may cause major shaft fatigue damage in one or relatively few incidents of severe switching disturbances.

The switching disturbances of primary concern are steady-state switching of lines and high-speed reclosing of circuit breakers following transmission line faults. These issues are discussed next.

A. Steady-State Switching of Lines

The switching of lines near a generating station for maintenance purposes may produce a step change in power that will result in transient mechanical forces on both the rotating and stationary components of a turbine generator. This sudden change in power is a function of the system impedance and the switching angle across the open circuit breaker. Studies have shown that if the instantaneous change in power, ΔP , during steady-state switching operations does not exceed 0.5 pu, the duty (loss of life) on the turbine generator will be negligible. If this power change exceeds 0.5 pu, the turbine generator manufacturer should be consulted to determine if there is potential turbine generator damage.

B. High-Speed Reclosing of Circuit Breakers Following Transmission Line Faults

High-speed reclosing of transmission lines at or near a generating station following a fault has the potential to cause major shaft fatigue damage to a turbine generator. Of particular concern is the possibility of an unsuccessful reclosure into a persistent fault that may reinforce the torsional oscillations and shaft torques caused by the original disturbance, possibly causing a significant loss in fatigue life of turbine generator shafts.

Reclosing practices can minimize the potential detrimental effects of high-speed reclosing of transmission lines near generating stations. When applying reclosing practices, the engineer should consider the following:

- Delayed reclosing for all faults. A delay of 10 seconds or longer is suggested.
- Sequential reclosing. Reclose initially from the remote line end, and block reclosing at the generating station if the fault persists. This approach is only applicable if the remote line end is not electrically near turbine generator units. Reclosing from the remote end on long lines may cause transient overvoltages if the other end of the line is a weak source.
- Selective high-speed reclosing. The type of reclosing used (high-speed or delayed) depends on the type or severity of fault.
- Single-phase tripping and reclosing. Trip only the faulted phase, and delay reclosing until after secondary fault arc extinction. This practice provides an advantage that the remaining connected phases tend to hold the machine in synchronism during the first clearing attempt, minimizing power swings and helping to maintain stability.

IV. SYNCHRONIZING [1]

Improper synchronizing of a generator to a system may result in damage to the generator step-up (GSU) transformer and any generating unit. The damage incurred may be slipped couplings, increased shaft vibration, a change in bearing alignment, loosened stator windings, loosened stator laminations, and fatigue damage to shafts and other mechanical parts. The windings and insulation blocking of the connected GSU transformer can also be damaged because of the high current that can flow during a faulty synchronization.

To avoid damaging a generating unit during synchronizing, the generator manufacturer will generally provide synchronizing limits in terms of breaker closing angle and voltage matching. Typical limits are:

- Breaker closing angle within ± 10 electrical degrees. The closing of the circuit breaker should ideally take place when the generator and the grid are at zero degrees phase angle with respect to each other. To accomplish this, the breaker should be closed in advance of phase angle coincidence to accommodate

for the breaker closing time. This is mathematically expressed as:

$$\theta = 360 F_S T_S \quad (1)$$

where:

θ is the advance angle in degrees.

F_S is the slip frequency in Hz.

T_S is the breaker closing time in seconds.

- Voltage matching 0 to +5 percent. This limit aids in maintaining system stability by ensuring some VAR flow into the system. Additionally, if the generator voltage is excessively lower than the grid when the breaker is closed, sensitively set reverse power relays may trip.
- Frequency difference less than 0.067 Hz. The frequency difference should be minimized to the practical control/response limitations of the given prime mover. A large frequency difference causes rapid load pickup or excessive motoring of the machine. This manifests itself both as power swings on the system and mechanical torques on the machine. Additionally, if the machine is motored, sensitively set reverse power relays may trip.

Slip frequency limits applied for certain machine types are based on the ruggedness of the turbine generator, the controllability of the turbine generator, and generator capacity (MVA).

Several synchronizing approaches may be used to minimize the possibility of damaging a generator, such as automatic, semiautomatic, and manual synchronizing.

A. Automatic Synchronizing System

Complete automatic synchronizing includes an integrated combination of elements that monitor voltage magnitude, phase angle, and rate of change of the phase angle across a controlled circuit breaker. It takes into account the closing time of the controlled breaker to predict when to initiate closing. This system includes an automatic synchronizer and elements (relays or modules) to monitor and control the frequency and voltage of the generator.

The synchronizing relay measures the speed of the generator relative to the system and the phase angle between the generator and the system. The relay then gives a closing impulse to the breaker at the correct angle in advance of synchronism to ensure that the breaker poles will close when the machine and system are in phase. For a given breaker closing time, the closing impulse will be given at the correct angle in advance of synchronism provided that the frequency difference is within a set limit. In general, there should be a small difference in frequency between the generator and the system for the synchronizing relays to operate.

The speed-matching relay is used to automatically match a generator frequency to a system frequency. The relay produces impulses that may be used to raise or lower generator speed. In general, generator speed is adjusted to be slightly higher than system frequency for synchronizing

purposes to prevent motoring or tripping on reverse power. Synchronism-check relays are often applied with automatic synchronizers to supervise the automatic control function.

In some instances, the speed-matching and voltage-matching functions are provided with the automatic control systems supplied with the generator.

B. Manual and Semiautomatic Synchronizing Systems

The manual synchronizing system relies on the operator's judgment for breaker closure while controlling generator voltage and frequency. The information required for the operator to make a closing decision is provided by a group of instruments. The operator's action may be supervised by additional devices but are transparent to the operator. These devices act as permissive only and do not match speed and voltage or initiate closure.

The semiautomatic synchronizing system has aspects of both the manual and automatic systems in that the operator has supervision of the automatic device and may directly control the generator speed and voltage.

The relay used to perform the supervisory function is a synchronism-check relay. Depending on the sophistication of the applied relay, it may be of the phase angle/time and voltage variety or phase angle/slip relationship and voltage variety. The setting of the synchronism-check relay should be set to the maximum angle expected at the maximum slip frequency allowed. In general, with this type of relay, the angular difference for synchronizing can be limited to 10 degrees or less. High-speed synchronism-check relays should be used for this supervisory role for either the automatic or manual synchronizing applications because of the quick, repeatable response on rotating phase angle applications.

V. SYNCHRONOUS CONDENSER OPERATION [1]

A synchronous condenser is used to supply or absorb reactive power. The system supplies power to keep the machine rotating synchronously. The same protective devices and application principles can be applied as would be used on a generator, except that reverse power relays cannot be applied because the machine is importing power from the system.

Some machines, especially hydroelectric generators, may be operated in synchronous condenser mode with zero or small exported power. It is possible (without service of underexciter limiter) for the loss-of-field relaying schemes to operate unnecessarily when the generator is underexcited (i.e., taking in reactive power approaching machine rating). To prevent unnecessary operations, an undervoltage relay may be used to supervise the loss-of-excitation scheme. The dropout level of this undervoltage relay would be set at 90 to 95 percent of rated voltage, and the relay would be connected to block tripping when it is picked up and would permit tripping when it drops out. This combination provides protection for almost all loss-of-field conditions but may not trip when the generator is operating at light load, because the voltage reduction may not be sufficient to cause relay dropout.

VI. PROTECTION DURING STARTUP AND SHUTDOWN [1]

During startup or shutdown of a generator, and in particular cross-compound units, the unit may be operated at reduced and/or decreasing frequency with the excitation (field) applied for a period of time. When operating below the rated frequency, the sensitivity of some of the generator zone protective relays may be adversely affected. The sensitivity of a few relays will only be slightly reduced while other relays will not provide adequate protection or become inoperative. Fig. 5 shows the effects of frequency on the pickup of electromechanical relays that may be used in the generator zone. Note that some relays lose sensitivity rapidly below 60 Hz. Induction disk current relays may provide adequate protection down to 20 Hz, while plunger-type voltage relays are not adversely affected by off-frequency operation.

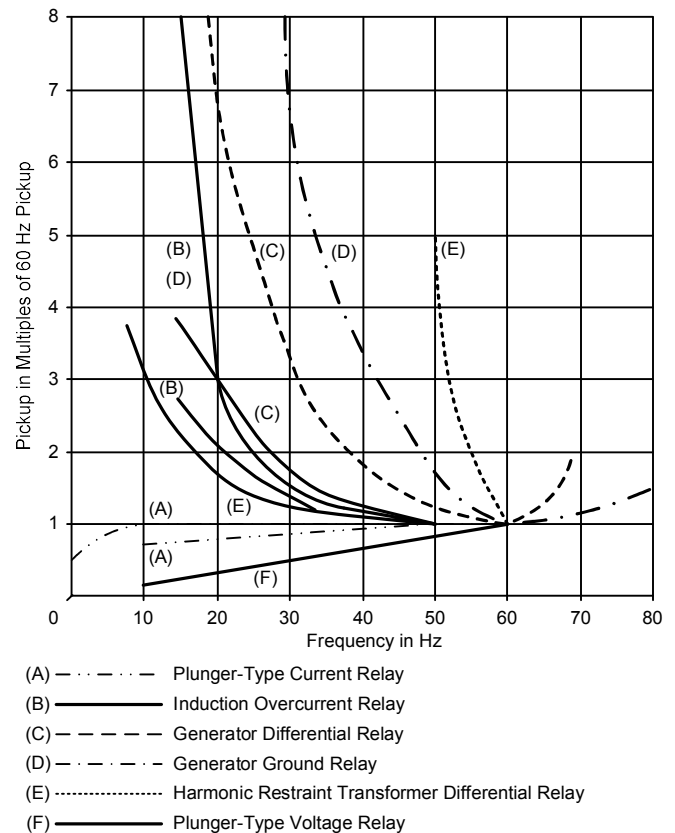

Note: Curves with like letters indicate comparable relays of different manufacturers.

Fig. 5. Example of Relay Pickup With Frequency

Supplementary protection during startup or shutdown of a unit-connected generator and its associated transformer may be provided through the use of protective relays whose pickup is not adversely affected by frequency, such as instantaneous overcurrent (IOC) or plunger-type voltage relays. Supplementary protection using plunger-type voltage relays should be placed in service only when the generator is disconnected from the system, as these relays are not suitable for continuous operation in the picked-up state.

Supplementary ground fault protection may be provided by using a plunger-type voltage relay connected in parallel with the normal ground overvoltage protection.

Solid-state relays and digital protection systems have various frequency response characteristics. The specific effect of off-frequency operation should be checked with the manufacturer. No supplemental protection may be needed if the relays perform adequately at low frequencies.

VII. SUBSYNCHRONOUS RESONANCE (SSR) [1]

When a generator is connected to a transmission system that has series capacitor compensation, it is possible to develop subsynchronous frequency oscillations and shaft torques that can be damaging to the generators. When a generator will be operating on such a series-compensated system, the user should work closely with the generator manufacturer to ascertain the severity of the problem and define the requirements for equipment to protect the generator on a particular system. The successful mitigation of the oscillations may be accomplished by equipment selection and control and protection techniques.

A. Equipment Selection

Determination of the proper amount of series compensation to avoid SSR requires extensive studies.

B. Control

Several control techniques may dampen oscillations before a trip is necessary, for example:

- The application of supplementary control in the excitation system to provide damping torque.
- Subsynchronous blocking filters to limit subsynchronous currents.
- Series capacitor bypass switches that close upon detection of SSR.
- Torsional dynamic stabilizers.

C. Protection

Protective devices may be applied to remove a generator from the system as the primary protection against SSR or as a backup to other SSR mitigation. A torsional relay may be set to trip for both low-level oscillatory torques that are growing in magnitude and for very high-level torques occurring between different sections of the shaft. Relay inputs could include instantaneous shaft-speed deviation or instantaneous generator power. A torsional protection relay may also be set to trip when oscillations persist.

Monitoring systems can be applied to turbine generators to record SSR events and provide information on shaft loss-of-life. One type of monitoring scheme calculates shaft torques from measurements of generator voltages and currents. Another alternative is to monitor actual shaft torques. Monitoring equipment enables post-event analysis that may be helpful in evaluating the performance of SSR mitigation and protection systems.

VIII. REFERENCES

- [1] *IEEE Guide for AC Generator Protection*, IEEE Standard C37.102-2006.
- [2] M. Reichard, Z. Bukhala, T. Beckwith, E. Fennell, D. Finney, D. Fredrickson, J. Gardell, W. Hartmann, P. Kerrigan, P. Kumar, D. Lukach, C. Mozina, S. Patel, and J. Uchiyama, "Protection Considerations for Combustion Gas Turbine Static Starting," IEEE PSRC Working Group J2 Report to J Subcommittee, 2009.
- [3] N. O. Engebretson, J. R. Boyle, H. L. Goodridge, C. H. Griffin, S. H. Horowitz, R. A. Larkin, R. E. Linton, G. D. Paradis, A. C. Pierce, B. M. Rice, W. R. Roemish, W. H. VanZee, C. L. Wagner, and S. V. Watson, "Protective Relaying for Pumped Storage Hydro Units Rotating Machinery Protection Subcommittee of the IEEE Power System Relaying Committee," *IEEE Transactions on Power Apparatus and Systems*, vol. 94, issue 3, pp. 899–907, May 1975.

Tripping Modes

Kevin Stephan and Sungsoo Kim

Abstract—This section of the tutorial provides insight into the basic objectives and industry recommended practices for tripping a generating unit once an abnormality or short circuit has been detected that requires the removal of the unit from service. Applying the proper tripping schemes on generating units should not be underestimated. This effort requires a broad knowledge of the generating unit equipment and its behavior during normal and abnormal conditions. Selection of the proper method of isolating a generator will minimize damage and provide a rapid return to service.

I. INTRODUCTION

A generating unit represents a significant investment for its owners. The generating unit is defined as the turbine (steam, gas, or hydroelectric), generator, transformers, excitation system, bus duct, conductors, terminal equipment, and circuit breakers. The general design objectives of protection systems and their associated tripping schemes include the following:

- Remove only the faulted section from the power system, thus preventing or minimizing the disturbance effect on the unfaulted parts of the system.
- Minimize or prevent damage to equipment.
- Ensure to the maximum possible extent that no single contingency will totally disable the protection on any system.
- Provide the means to permit fast return to service of the affected equipment.

More specifically, the objective of the generating unit protection tripping schemes is to ensure that the effects of faults and disturbances are restricted to local areas. The tripping schemes should be capable of meeting this requirement while experiencing a first-order contingency, such as the failure of a single protective relay to operate or the failure of a breaker to trip.

II. TRIPPING SCHEMES

Generally, discrete generator protective functions are grouped together to activate auxiliary tripping relays so that functions with the same generator trip/shutdown modes are established. Where possible, the arrangement of the auxiliary tripping relays should provide redundancy in both trip paths and trip functions, allowing backup relays to trip a separate auxiliary tripping relay from the primary protection. Applying tripping schemes on generating units should not be underestimated. This effort requires a broad knowledge of the generating unit equipment and its behavior during both normal and abnormal conditions. It would be shortsighted to consider only disconnecting the generator from the electrical system

without taking into consideration the precise manner in which the generating unit can be isolated from the power system.

For example, auxiliaries for generating units consist of pumps, fans, etc., necessary to operate the unit. For most thermal units (steam, etc.), these auxiliaries must be powered during startup and shutdown as well as while the unit is running. During startup and shutdown, these auxiliaries are powered by a station service source, sometimes referred to as "reserve" or "standby" sources. When the generating unit is online, the auxiliaries are normally switched or transferred to a unit auxiliary transformer (UAT) that is supplied from the generator terminals. When a generator is shutdown, either planned or unplanned, the auxiliaries are transferred to the station service source. The transfer is automatic during a protective trip depending on the tripping mode and protective functions.

Four common methods for isolating the generator from service following unacceptable abnormal operating conditions or electrical faults are described here.

A. Simultaneous Tripping

Simultaneous tripping provides the fastest means of isolating the generator. This tripping mode is used for all internal generator faults and severe abnormalities in the generator protection zone. Isolation is accomplished by simultaneously tripping the generator breaker(s), field breaker, and turbine valves to shut down the prime mover. Auxiliary loads are transferred to a standby source. If a potential for significant overspeed condition of the unit exists, a time delay may be used in the generator breaker trip path. If a time delay is applied, the effect of this delay on the generator and/or system should be determined.

B. Generator Tripping

This mode of isolation trips the generator and field breakers and transfers the auxiliaries. The scheme does not shut down the prime mover and is used where it may be possible to correct the abnormality quickly, thereby permitting a rapid reconnection of the machine to the system. The protection, which trips the generator for power system disturbances rather than internal generator faults and/or abnormalities, can trip through this mode if permitted by the type of prime mover and boiler system (i.e., the machine allows full-load rejection).

C. Unit Separation

The unit separation tripping scheme is similar to generator tripping but initiates only the opening of the generator breakers. This scheme is recommended when maintaining the unit auxiliary loads connected to the generator is desirable.

For example, during a major system disturbance that requires tripping because of low frequency, the standby source may be unavailable. The advantage of this scheme is that the unit can be reconnected to the system with minimum delay. This trip mode requires that the unit be capable of an excitation runback operation following a full-load rejection trip.

D. Sequential Tripping

The sequential tripping mode is primarily used on steam generators to prevent overspeed when delayed tripping has no detrimental effect on the generating unit. It is used to trip the generator for prime mover problems where high-speed tripping is not a requirement. The first devices tripped are the turbine valves. Then, the generator breaker(s) and field breaker are tripped, and the auxiliary load transfer is initiated by a reverse power relay in series with a “turbine valves closed” position switch, providing security against possible overspeed of the turbine by ensuring sufficiently reduced steam flows. For boiler/reactor or turbine mechanical problems, this is the preferred tripping mode because it prevents machine overspeed. However, one disadvantage is the lack of an output for a failure of the turbine valve limit switches or reverse power relay. When this approach is used, backup protection should be provided to ensure tripping in case of failure. This protection is generally provided by a separate reverse power relay that initiates independent tripping. Sequential tripping schemes should be reviewed for correct operation during unit islanding conditions when there is no reverse power to trip the generator (i.e., the high-voltage generator breaker is open, and the generator is feeding its own auxiliaries). During such conditions, another protective function should be incorporated. Keeping unit underfrequency relaying enabled when the generator breakers are open is one option to complete the sequential trip. The sequential trip mode should not override the generator switchyard protection that instantaneously opens the generator breaker when a critical electrical fault occurs that might cause serious damage to the generator or switchyard equipment.

Table I indicates the specific trip action for each trip mode described previously.

TABLE I
TRIPPING ACTION

Tripping Mode	Generator Breakers	Field Trip	Prime Mover Trip	Transfer Auxiliaries
Simultaneous Trip	X	X	X	X
Generator Trip	X	X		X
Unit Separation Trip	X			
Sequential Trip	X*	X*	X	X*

* Generally supervised by turbine valve position switch and reverse power relay

III. TRIPPING SCHEME SELECTION

Many factors contribute to selecting the appropriate tripping scheme. Several key items include the following:

- Type of prime mover: diesel/gas engine, gas turbine, steam turbine, or waterwheel.
- Impact of the sudden loss of output power on the electrical system and prime mover.
- Safety to personnel.
- Operating experience.
- Management of unit auxiliary loads during emergency shutdown.

Fig. 1 depicts the typical complement of protection on a unit-connected generator, including the UAT. Table II and Table III suggest trip logic for the various protective relays. Many of these protective functions are discussed in other sections of this tutorial. Table II was adapted from the IEEE C37.102 Guide for AC Generator Protection [1]. Table III comes from recognized hydroelectric utility experience. Both tables provide guidance in developing an overall generator protection trip scheme. Individual trip schemes will vary depending upon owner preference, operating experience, and specific capabilities of the prime mover and boiler systems. Both tables provide generally accepted industry practices.

The trip requirements of hydroelectric generators are very similar to those of thermal generators in many respects. Despite their similarities, however, the hydroelectric generators may require slightly different trips and shutdown operations. This is because the hydroelectric generators are salient pole machines and relatively slower rotating devices equipped with different mechanical control devices than those of high-speed steam turbine generators.

Auxiliary power for the safe shutdown of big hydroelectric generators may not be as critical because of sufficient stored energy in the hydraulic oil and air systems that close the gates and apply the brakes to the machines. In addition, the use of unit-connected auxiliary power systems is limited and only one of several configurations used in hydroelectric plant design. Hydroelectric auxiliary power systems can have more than one source, and if automatic transfer is implemented, it is often controlled by availability of the source rather than unit tripping [2].

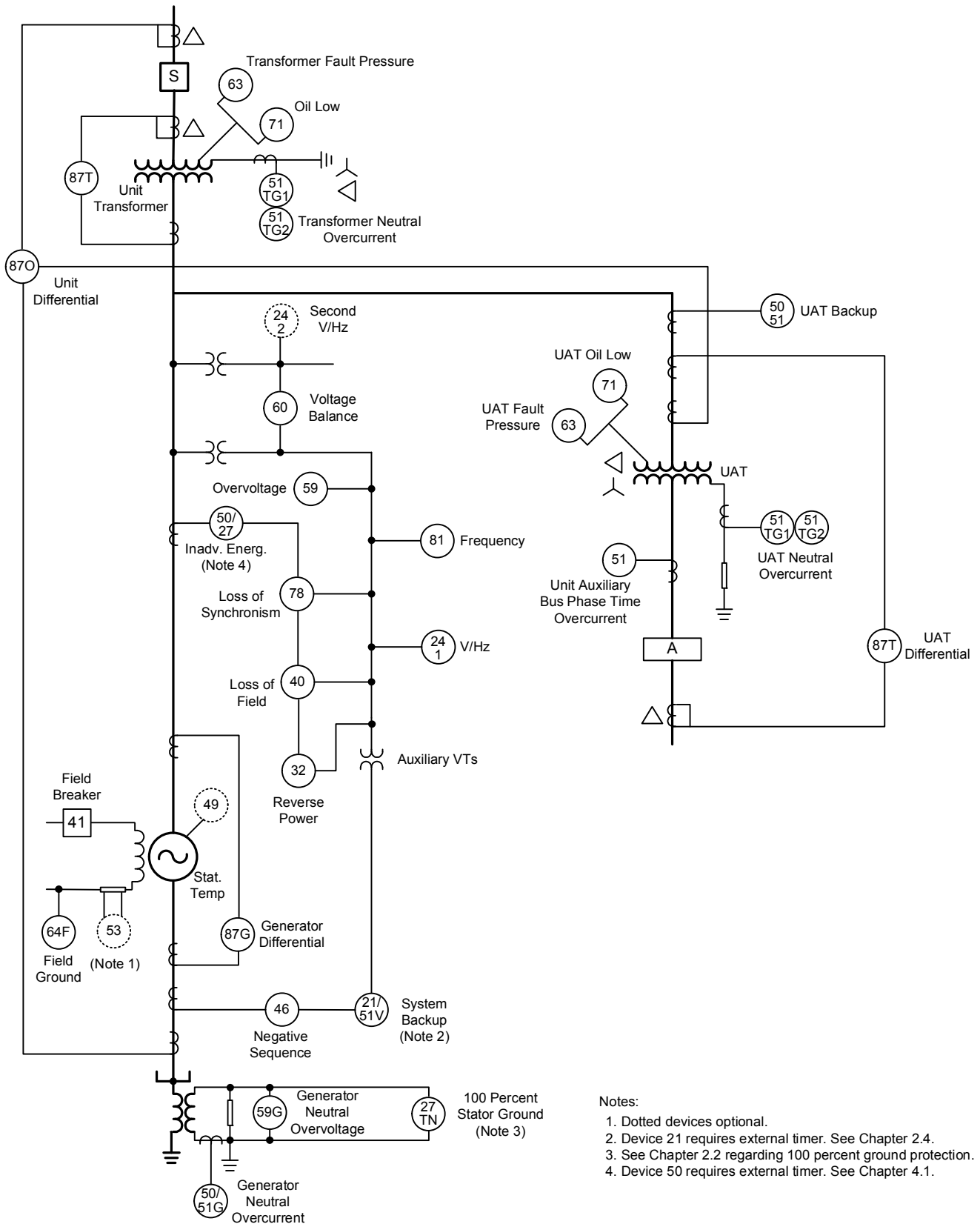

Fig. 1. Typical Unit Generator-Transformer Configuration

TABLE II
SUGGESTED STEAM UNIT TRIP LOGIC

Device	Lockout	Generator Breaker Trip	Field Breaker Trip	Transfer Auxiliaries	Prime Mover Trip	Alarm Only
21 or 51V	86G2	X	X	X	X	
24	86G1	X	See Note 2	X	See Note 11	
32	86G2	X	X	X	X	
40	86G1	X	X	X	See Note 12	
46		X	See Note 7	See Note 7	See Note 7	
49						X
50/27 (See Note 10)		X	X	X	X	
50/51G	86G2	X	X	X	X	
51TG1		X				
51TG2		X	X	X	X	
51TG1 UAT		See Note 6	See Note 6	See Note 5	See Note 6	
51TG2 UAT		X	X		X	
50/51 UAT		X	X	See Note 5	X	
53			See Note 2			X
59	86G2	X	X	X	See Note 11	See Note 1
59G (See Note 9)	86G1	X	X	X	X	See Note 3
60						X
63		X	X	X	X	
63 UAT		X	X	X	X	
64F		See Note 4	See Note 4			X
67N (See Note 3)		X	X	X	X	
71						X
71 UAT						X
78		X	See Note 8	See Note 8	See Note 8	
81		X				
87G	86G1	X	X	X	X	
87GN (See Note 13)	86G1	X	X	X	X	
87T	86T	X	X	X	X	
87T UAT	86UAT	X	X	X	X	
87O	86G2	X	X	X	X	

Notes:

1. Device 59 may be connected to alarm only on some units.
2. If the generator is offline, trip only the field breaker.
3. Used for bused high-impedance grounded generators [1].
4. May be connected to trip per generator manufacturer.
5. Trips the unit auxiliary bus incoming breaker (Breaker A in Fig. 1).

6. If tripping Breaker A results in loss of auxiliaries, these trips are required, and 51TG2/UAT protection is not required.
7. Refer to Chapter 3.4.
8. Refer to Chapter 3.6.
9. 27TH, 59TH, 59THD, 64S trip logic is similar to 59G.
10. The 50/27 function uses voltage supervised overcurrent relaying for inadvertent energizing protection. Other protection functions described in Chapter 4.1 use the same trip logic.
11. Refer to Chapter 3.2.
12. Refer to Chapter 3.3.
13. Also trips low-impedance ground path in a hybrid grounding scheme.

TABLE III
SUGGESTED HYDROELECTRIC UNIT TRIP LOGIC

Device	Lockout	Generator Breaker Trip	Field Breaker Trip	Prime Mover Trip	Deluge (See Note 1)	Damper (See Note 2)	Alarm Only
A87SP (See Note 3)	86G1	X	X	X	X	X	
21		X	X	See Note 5			
24		X	X	X			
27							X
27TN/64G							X
32F		X	X				
32R		X	X	X			
40		X	X	X			
46		X	X	X			
50/27		X	X				
50BF		X	X	X			
59		X	X	X			
59N/64G	86G1	X	X	X	X	X	
64F							X
78		X	X	X			
81O		X	X	See Note 5			
81U (See Note 4)		X	X	See Note 5			
87	86G1	X	X	X	X	X	

Notes:

1. Deluge System: This function provides generator fire protection the generator and limits damage to other nearby generators, equipment, and structures. Two types of fire extinguishing agents are commonly used in the fire protection of generators: carbon dioxide and water. The system is activated by flooding either of these two agents when the simultaneous operation of both a heat activating device and protection operation is warranted.
2. Damper: To regulate the flow of air in a generator chamber, control dampers are normally provided that can be automatically and/or manually closed to starve the room of oxygen in case of fire.
3. Split-phase 87 protection.
4. Trip is optional.
5. No Load Speed (NLS) is referred to as the normal, synchronous speed of the unit (100 percent) when the unit is not connected to load. At this speed, the unit is ready to be synchronized to the system. Governors and gate controllers usually have a preset value that corresponds to a gate position that will spin the unit at or close to NLS.

IV. OTHER CONSIDERATIONS IN DEVELOPING TRIPPING PHILOSOPHY

Concern has arisen over several major accidents related to tripping philosophy in generating stations. In large power plants, a breaker-and-a-half or ring-bus yard layout with a disconnect on the generator feed is commonly used. Fig. 2 shows such arrangements.

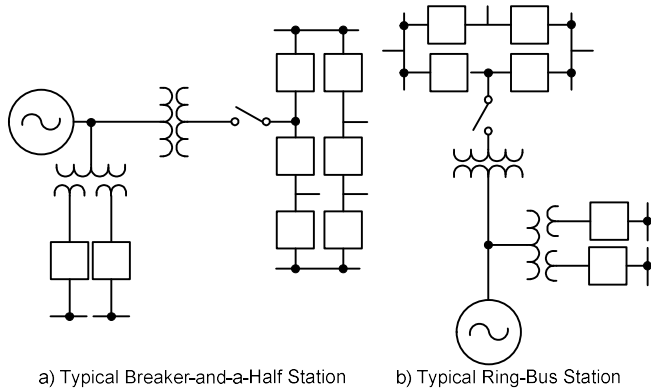

Fig. 2. One-Line Diagrams of Typical Generator Stations

These configurations allow the generator to be taken offline, the disconnect to open, and the breakers to close to maintain another tie between the main buses. In the early phases of plant construction, it is common for ring-bus configurations to be expanded later to a breaker-and-a-half. The ring configuration requires a disconnect switch on the generator feed that can be opened to allow closing the ring when the generator is offline. Some engineers have used auxiliary contacts in the motor operator of these disconnect switches to disable some or all of the generator protection when the generator is offline. While this appears to be a convenient indication of the status of the machine, it can be fooled by abnormal conditions.

A. Disconnect Switch

When protective relaying is routinely disabled with auxiliary contacts from the disconnect switch, the following should be carefully considered. Because of adjustment and linkage problems, the auxiliary contacts may not properly close, and vital protection can be out of service when needed most. Also, if the auxiliary contacts are located inside the motor operator compartment, the contacts may only follow the motor mechanism and not the actual switch blades. When the motor operator is uncoupled from the switch shaft and the switch is closed manually, the protection will be out of

service. Even if the auxiliary stack is mounted to follow the disconnect switch operating shaft, reliability problems can arise. Several very serious accidents can be traced directly to using auxiliary contacts to disable protection; therefore, this practice is not recommended.

Some control schemes use the disconnect switch auxiliary contacts to disable certain boiler trips while the machine is in startup. This practice is fairly common on coal-fired units where it takes a long time to get the machine online. If a nuisance trip occurs, many hours may be wasted. While it is necessary to be sensitive to boiler control problems, the generator protection must not be compromised during the startup process by disabling its ability to trip the turbine and/or boiler.

B. Maintenance

When the generator is offline for maintenance, safety rules and procedures may require the generator potential transformers to be racked out and tagged. Also in some instances, current transformers may be shorted and the station dc tripping source may even be disconnected. The design engineer must be aware of these possibilities when determining the type and location of generator backup and inadvertent energizing protection. If the generator is offline, the common belief is that protection is not needed. However, the long list of generators that have been inadvertently energized tends to support the need to have as much of the protection in service as possible, even when the machine is offline. Refer to Chapter 4.1.

V. CONCLUSION

Selecting the proper trip action of generator protective relays is one of the most important aspects of protecting generators. This task requires a broad understanding of generator protection, the capability of the generator and/or prime mover system and unit operating and maintenance practices. Selection of the appropriate tripping mode will minimize or prevent damage and provide for the rapid return to service of the unit.

VI. REFERENCE

- [1] *IEEE Guide for AC Generator Protection*, IEEE Standard C37.102-2006.
- [2] V. Tawtel, R. H. Stuart, "Station Service Systems for Large Hydroelectric Generating Stations," *IEEE Transactions on Power Apparatus and Systems*, vol. PAS-87, issue 2, Feb. 1968, pp. 579-584.

Multifunction Generator Protection Systems

Murty V. V. S. Yalla

I. INTRODUCTION

Generator protective relaying technology has evolved from discrete electromechanical and static relays to digital multifunction protection systems. Many protection schemes in service today use discrete electromechanical or static relay types that have a long history of providing reliable protection and continue to be applied in many applications. However, with the availability, additional performance, economic advantages, and reliability of digital multifunction protection systems, this advanced technology is incorporated into most new protection schemes. In most cases, new generators are protected with either dual multifunction generator protection systems (MGPSs) or a single MGPS, possibly backed up by single-function relays. Some modern excitation systems contain protection functions that may be considered as backup.

Digital technology offers several additional features that could not be obtained in one package with earlier technology. These features include: metering of voltages, currents, power, and other measurements; oscillography; sequence-of-events capture with time tagging; remote setting and monitoring

through communications; user configurability of tripping schemes and other control logic; reduced panel space and wiring; low burden on the VTs (voltage transformers) and CTs (current transformers); continuous self-checking and ease of testing.

Fig. 1 shows the block diagram of a typical MGPS. The general multifunction relay application is made up of two or more functions implemented on a single hardware platform. The MGPS has analog inputs (voltage and current signals), digital inputs for receiving contact status and other indications, and digital outputs for sending trip and alarm signals. The MGPS will also have bidirectional communications ports that may be EIA-232, EIA-485, fiber-optic, Ethernet, or some other hardware interface for external communication. Internal hardware consists of an analog data acquisition system that includes signal scaling, isolation, filtering (anti-aliasing), sample-and-hold, analog multiplexing, and analog-to-digital conversion. The digital subsystem consists of a microprocessor, ROM (read-only memory) for program storage, RAM (random-access memory) for temporary storage of information, and EEPROM (electrically erasable programmable memory) for storage of set points.

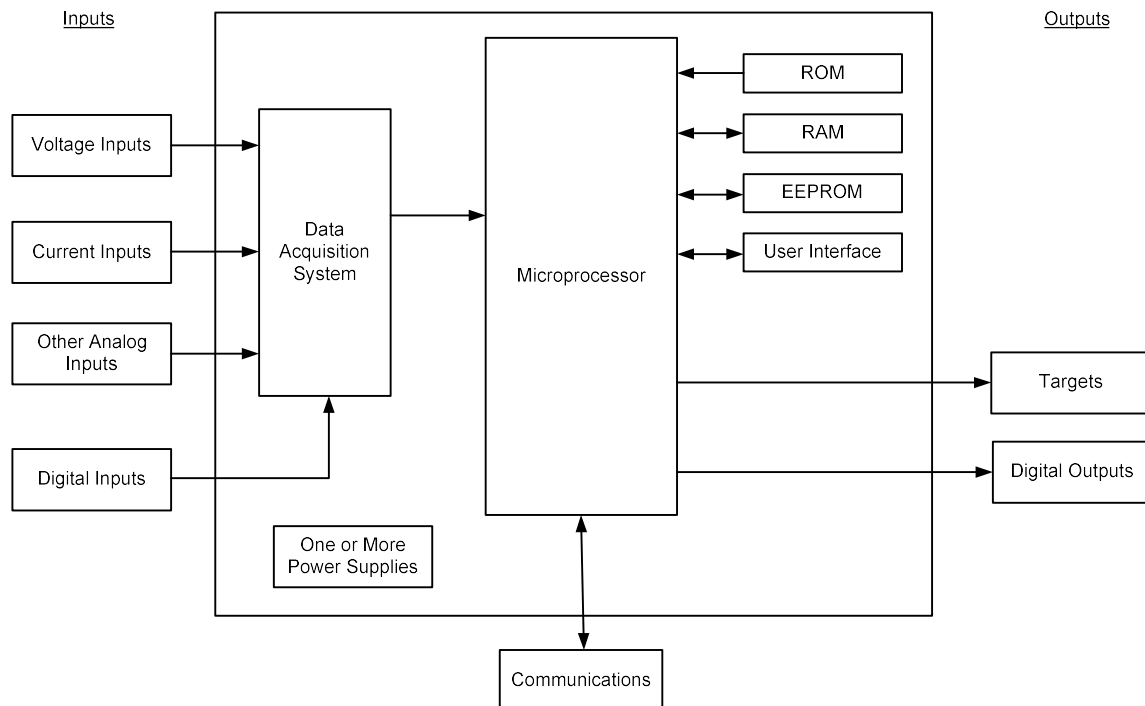

Fig. 1. Block Diagram of a Typical MGPS

The functional operation and performance of the MGPS are determined by both hardware and software programs. Digital signal-processing algorithms filter the voltage and current input signals and calculate the parameters (magnitudes and phase angles or phasors) required for the relaying functions. The relay logic software program compares the set points to the calculated parameters and implements the required time-delay characteristics. The software program also implements other features such as communication, oscillography, event record, and local-user interface.

II. APPLICATION ON A TYPICAL GENERATING UNIT

A. Protection Functions

Protection functions traditionally provided by individual component relays and now integrated into MGPS packages include two or more of the following:

- Generator phase differential (87G)
- Generator ground differential (87GN)
- GSU (generator step-up) transformer differential (87T)
- Stator ground (59G)
- 100 percent stator ground
 - Third-harmonic neutral undervoltage (27TH)
 - Third-harmonic voltage ratio or differential (59THD)
 - Subharmonic voltage injection (64S)
- Current unbalance/negative sequence (46)
- Loss of excitation (40)
- Overexcitation (24)
- Undervoltage (27)
- Overvoltage (59)
- Underfrequency (81U)
- Overfrequency (81O)
- Reverse power or directional power (32)
- Stator thermal (49)
- Overcurrent (51)
- System backup (51VC/51VR) or (21)
- Loss of voltage (60)
- Out of step (78)
- Field ground (64F)

Additional functions that may be provided include: sequential trip logic, accidental energization, and open breaker detection. By using programmed logic and appropriate protection elements within the MGPS, these functions may be implemented without the additional devices and wiring necessary with more traditional discrete relays. Because the different functions retain their accuracy over a wide frequency range, implementing separate startup or shutdown protection may no longer be necessary.

B. Protection Function Arrangement and Layout

Traditional applications of generator protective relays involved separate relays performing different functions with some overlap and backup where appropriate. In many cases, the generator differential relay was connected to a dedicated set of CTs to address reliability, burden, and CT characteristic matching issues. The low burden of an MGPS allows connection of differential and other protection to the same set of CTs without performance deterioration caused by CT burden. Using a single set of CTs concerns many application engineers because CT inputs are not duplicated in this scheme—resulting in lower reliability. However, if two MGPSs are applied, separate CT and VT inputs are recommended for redundancy.

Integrating many protection functions into one package raises reliability concerns. These issues are addressed by:

- Providing two MGPSs, each with a portion of the protection functions. Redundancy may be available for some or all protection functions.
- Providing backup for critical components, particularly the power supply.
- Using self-checking functions.

These measures help to minimize the effect of a single component failure. MGPS failure may require that the generator be taken out of service. However, present industry practice requires at least two MGPSs for each protection application for a generator that cannot be taken out of service because of a protective relay loss. In some cases, a redundant single-function relay, such as overall differential, may be applied in addition to the MGPS.

In the MGPS, self-tests and diagnostics detect many failure modes and alert the user through alarm outputs. The ability to detect and correct a failure before the protection system needs to operate is a contrast to traditional protection, where a relay failure would probably not be detected until the next maintenance test or until the relay false trips or fails to operate correctly during an event.

If two MGPSs are applied, the user has a number of choices on what protection function to include in each one. Some MGPSs provide full-function protection for large or important generators. Other MGPSs provide reduced protection functions for smaller or less important generators. Some MGPSs also provide user-configurable protection functions. Users should take into account factors such as the degree of redundancy required, oscillographic and communications capabilities, cost, training requirements, and preference for a particular design approach.

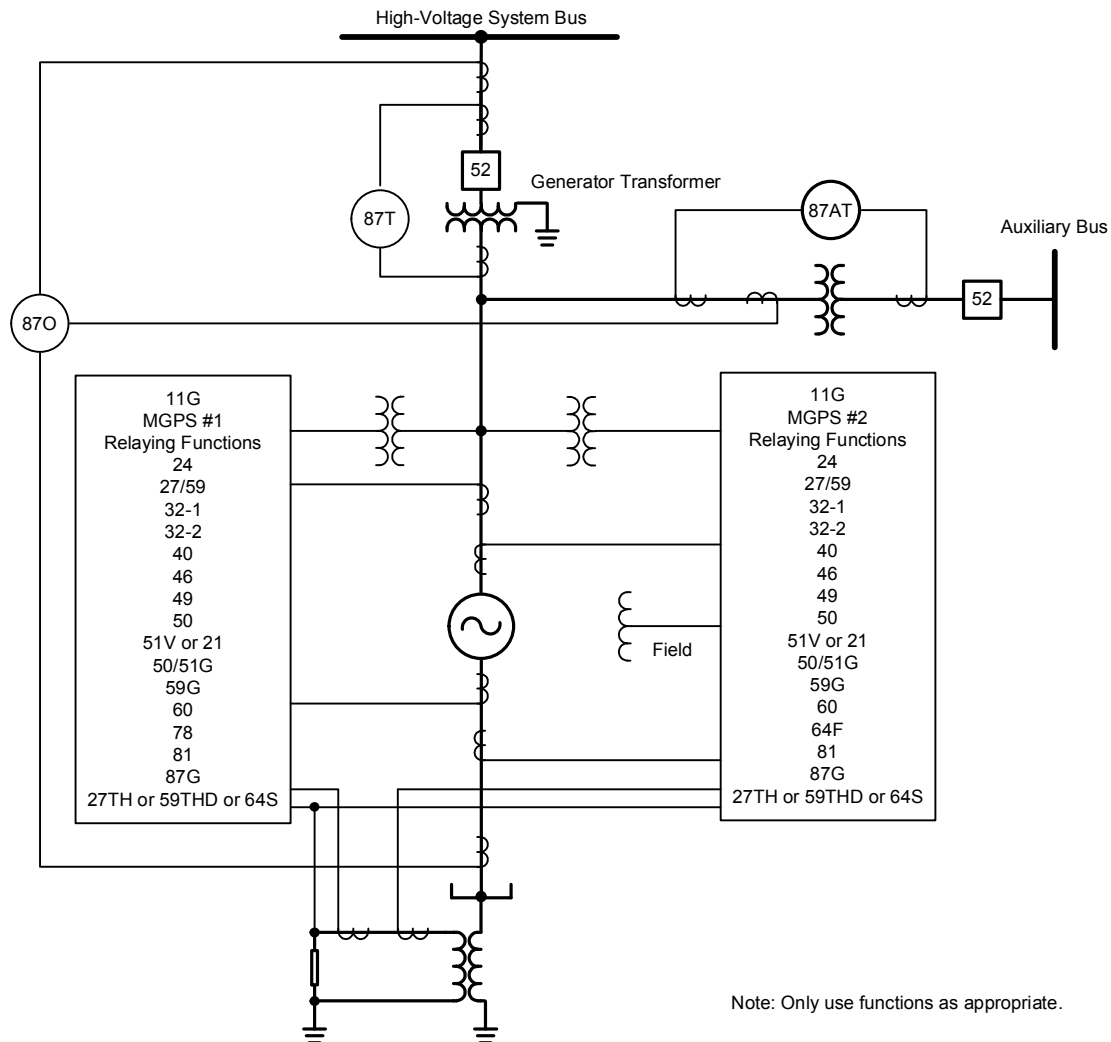

Fig. 2. Typical Protection for a Large or Important Generator

Fig. 2 is an example of a large or important unit generator-transformer configuration with two MGPSs, applied with redundant protection functions. This figure shows both MGPSs with almost the same protection functions. However, the application of two MGPSs allows the user to apply devices incorporating different operating principles that may improve the overall dependability of the protection scheme.

Each of the MGPSs has separate dc-to-dc power supplies and tripping circuits. The built-in self-monitoring and diagnostic functions are always online and detect many relay failures, thereby reducing the likelihood of false operation. Periodic testing and preventive maintenance may be reduced to a minimum because only the items and responses not fully covered by the self-monitoring and diagnostic functions need to be checked. If provided, the status of each MGPS may be determined by the station control system by cyclically interrogating the diagnostic function via the communications link. This check confirms that the self-monitoring system is working and the protection is available. Most available functions in various MGPSs are shown in Fig. 2. Actual functions available depend on the specific MGPS selected.

Also, the inputs (CT, VT, and RTDs [resistance temperature detectors], etc.) shown may vary depending on specific functions used.

C. Protection Function Tripping Schemes

The selection of a trip or alarm action produced by the operation of different protection functions varies by user, depending on their experience, philosophy, interpretation of standards, and turbine-generator manufacturer's recommendations. Many MGPSs allow the user the flexibility to route any individual protection function data to selected trip or alarm relay outputs. This design allows the trip scheme and logic to be configured for redundant trip paths to eliminate single-contingency failures of the trip relay. Additionally, this trip logic enables the user to consider the generator and prime mover's operational capabilities (type of prime mover, system configuration, regulator response, and boiler and governor control systems) to avoid unnecessarily stressing the unit. Four methods of isolating a unit (tripping) should be considered when applying an MGPS: simultaneous tripping, generator tripping, unit separation tripping, and sequential tripping (see Chapter 5.1).

The trip scheme shown in Fig. 3 employs more than one lockout relay (86) because different conditions dictate different types of tripping. Conditions such as generator and main transformer faults require the immediate and simultaneous tripping of the generator circuit breaker(s), field circuit breaker, and prime mover to minimize damage to the unit and disturbance to the system. Operating functions, such as negative-sequence current or abnormal frequency, require separation of the generator from the system but not necessarily tripping of the field circuit breaker or prime mover. Therefore, unit separation tripping may be appropriate. The reverse power function is shown as part of sequential tripping control logic. In this example, generator tripping is initiated by a combination of the reverse power function contact in conjunction with the turbine trip indication. Other functions, such as thermal protection, may only necessitate operator action and may alarm. The user should evaluate each function's impact on the equipment and system before determining the trip logic. The specific application should also be discussed with the turbine-generator manufacturer.

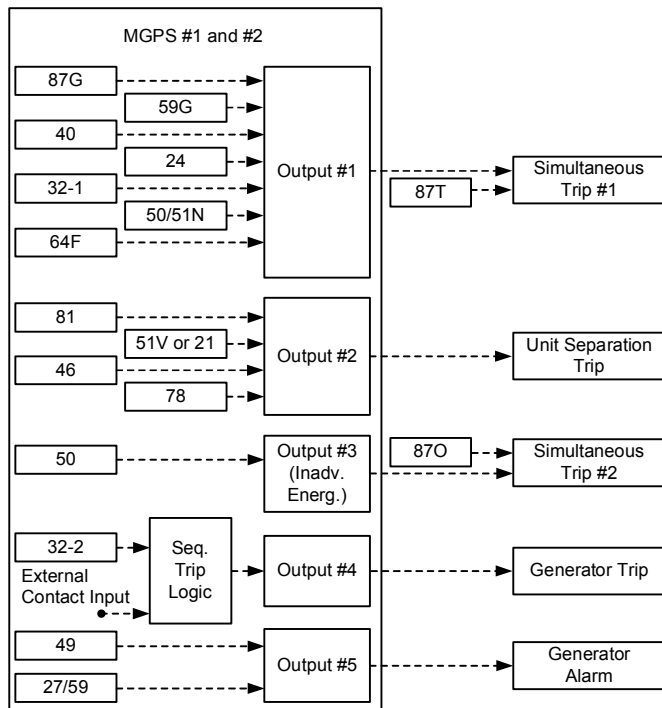

Note: Only use functions as appropriate.

Fig. 3. Typical Tripping Configuration for a Large or Important Generator

Fig. 3 shows the implementation of tripping logic for the protection of a unit-transformer configuration using MGPSs. Using two MGPSs allows further flexibility in the tripping logic configuration by eliminating common mode failures, thus allowing greater dependability. Initiating different lockout relays for the same function, such as the generator differentials on each MGPS, is an example of greater dependability. Initiating those same lockout relays, one with a generator neutral ground overvoltage function (59G) from one MGPS and the other MGPS with a generator neutral ground overcurrent function (50/51G), is an example of providing

redundant protection using alternative functions as a means of improving dependability.

III. MGPS TESTING

A. Evaluation Testing

Evaluation testing by the user or a third party provides demonstrated background and understanding of the functions and performance of the MGPS. This optimizes the utilization of the MGPS in that the understanding gained from the tests helps to determine the requirements for acceptable dependability (e.g., what functions, if any, should be duplicated) and the applicable commissioning and maintenance procedures.

B. Acceptance Testing

Many users subject all relays to acceptance testing. With an MGPS, consideration should be given to reducing the number of tests by designing the test program to exercise the integrity of each of the necessary hardware components, rather than each of the relaying functions (overvoltage, reverse power, loss of field, etc.). Evaluation testing as described previously may define the desirable complement of tests. Also, in the interest of producing an acceptance plan that is both efficient and thorough, the user may wish to look to the MGPS manufacturer for guidance because of their detailed knowledge of the MGPS design.

C. Commissioning and Maintenance Testing

Because the different functions in the MGPS operate on the same set of voltages, currents, and programmable logic available for output tripping, the commissioning tests on external wiring and trip circuits are simplified. Moreover, because each function shares analog inputs, testing of the individual relay functions for a given group of settings is easier to set up and perform than if these functions were in discrete relays. However, because more than one function may operate for a given set of test parameters and many functions operate the same output contact, identifying which relay element has operated to close the output contact may not be easy. Options to address this situation include:

1. Facilitate testing of individual functions by using an MGPS that provides a test mode in which only a selected function operates the test output contact.
2. Design the test inputs and sequence so that only one function will operate for a given set of test inputs.
3. Use the MGPS event report as an adjunct to the output contact closure.
4. Temporarily reprogram the output to an isolated contact.

Some users will object to the fourth method because a large part of testing an MGPS is to check its programming. The second method requires some planning and proper test equipment. Combining the second and third methods likely will produce a test plan that avoids confusion as to which relay function has caused a trip.

Some considerations for selecting the test parameters include:

- Test functions such as V/Hz, overvoltage, and abnormal frequency with no current applied so that the current and impedance functions will not operate.
- Test V/Hz at less than nominal frequency so that its pickup will be below the setting of voltage and frequency relays.
- Test distance, power, and loss-of-field functions with currents applied to both phase and neutral-side inputs so that the differential function will not operate.

The commissioning tests discussed here may be the result of a task in the evaluation tests discussed previously. Furthermore, periodic maintenance testing may be a subset of the commissioning tests. Maintenance tests should at least verify the proper functioning of all input and output circuits. Some MGPSs provide test access for injecting voltage and current signals for maintenance testing. In deciding the frequency of maintenance testing, self-diagnostic features have justified reduction in the frequency of testing. However in the case of an MGPS, certain caution is also justified because self-diagnostic features do not test the contact inputs or outputs, the failure of which has a larger impact than that of a single-function relay.